

Figure II.3.11 - MICRO-CONTACTS TRAINS (avion au sol, trains sortis)
LDG MICROSWITCHES (airplane on ground, LDG extended)

TB20 60011

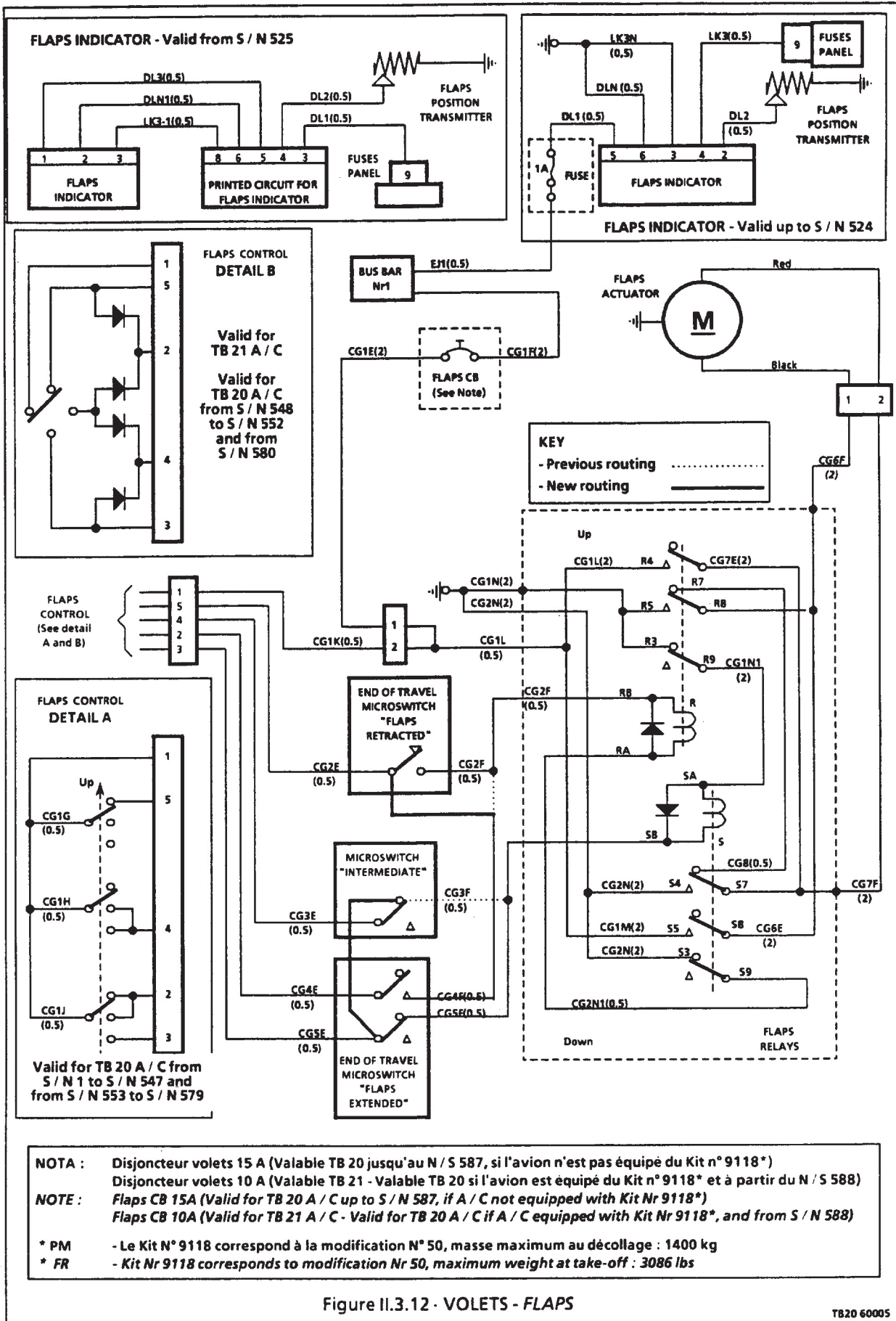

Figure II.3.12 - VOLETS - FLAPS

TB20 60005