



Safety Spot  
By Malcolm McBride

# LOW-HOURS PROPELLER INSPECTION PROTOCOL, AEROTECHNIK WHEELS & SPORTCRUISER NOSELEGS

The latest LAA Engineering topics and investigations

**H**ello again and welcome to *Safety Spot*, as always, we hope you're in good form physically and not too depressed about the fact that winter is just around the corner and the long summer days are about to become just another memory.

Over the years, I've often said that I applaud any season's arrival – I just love the changes brought about as a result of the battles fought above us between the various major weather systems. After all, every season brings its pleasures. So, as the sun drops over the southern horizon and UK temperatures fall, we all need to locate our favourite jumper and set about preparing for the shorter days.

As usual, and much to the consternation of our editor, Brian Hope, I'm again working right up to the deadline for this October edition of *Safety Spot*, so I had better get on with it! That said, I should mention this morning's personal weather event as it carried a message which is worth sharing.

As you may know, my much-preferred mode of transport is my trusty (touch wood) Triumph motorcycle. Before I head off anywhere I'm in the habit of checking the weather, whether it's by bike, plane, car or boat, it doesn't matter, as I've learnt that if you're planning on travelling from A to B, it's worth doing a bit of research to see what the en route and destination conditions are going to be, and don't forget the forecast if you need to come back. The actual 'my back garden' weather this morning was lovely, with a little very high cloud, no sign of rain and a gentle breeze from the southwest. Normally, it'd be a 'bike' day for me, but I know that the UK has been expecting the arrival of the first storm of the season – it's a bloke's name this year: Ali.

I don't like being bashed about by a strong wind on a bike, or when commanding anything else really, but especially on the Triumph I'm always worried about stuff blowing in front of me while I'm on the move as errant (or perhaps erratic) motorists are worrisome enough. So, I came in on four wheels today. Sure enough, by the time I headed off for my daily lunchtime perambulations around the airfield, Storm Ali had arrived!

My walk took me first in front of, then side-on to and subsequently against a 35kt wind – it was hard work, just what the doctor ordered. While heading along my preferred path, alongside a wee burn, the wind was side-on and, without any warning whatsoever, a great branch broke off an old tree and landed with a thump not five metres in front of me. Perhaps the lesson should be amended by that message sent (literally) from above, namely

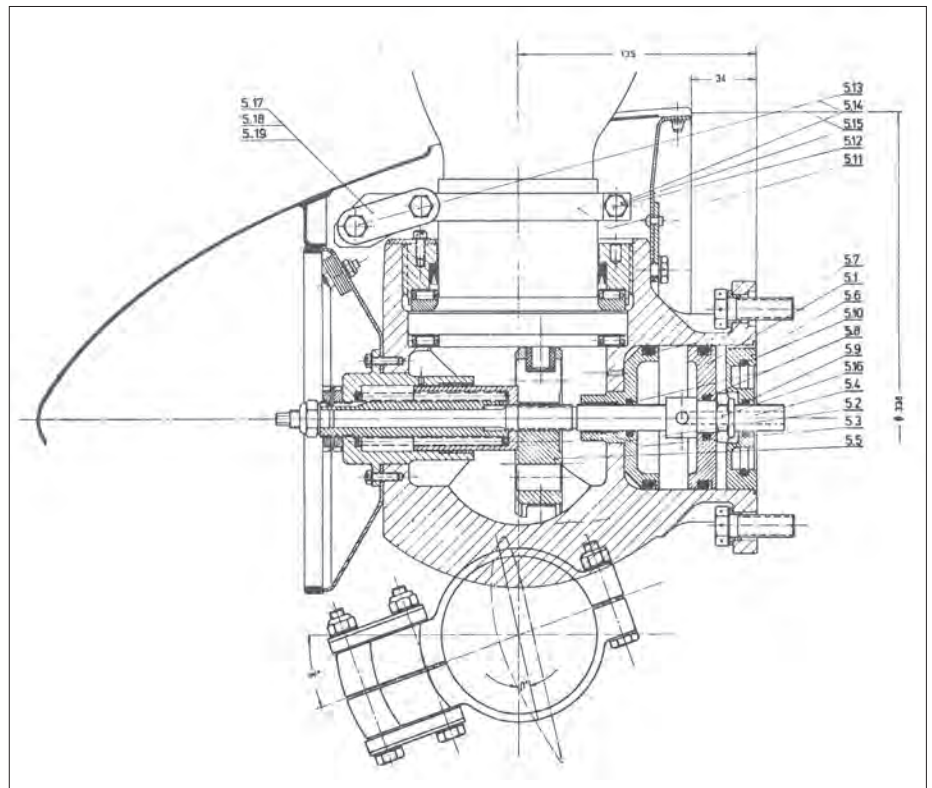

(Above) It's easy to forget that a propeller is one of the hardest-working devices on a sports aircraft. Every time you start the engine almost unimaginable forces travel through the components which go to make up the prop assembly, and that's why it's essential to follow manufacturer's inspection guidelines. Naturally, variable-pitch propellers are complicated devices and most of the working parts are hidden from view so the services of a professional 'prop shop' are needed to inspect it properly.

Manufacturers' overhaul requirements are driven by two basic realities: one, things wear out and, two, they degrade over time. Because LAA aircraft normally fly relatively few hours in the year, wear isn't normally an issue but degradation and the effects of corrosion can be. That's why LAA Engineering, after consultation with manufacturers, the CAA and commercial propeller shops, have introduced the Low-Hour Propeller Inspection Protocol (LPIP). With LPIP there's a limited inspection for wear, so no expensive NDT or blade strip. The focus of the inspection is to ensure that the 'innards' are all working correctly, the seals are replaced and any early signs of corrosion (which are often present) are dealt with before it has the chance to contribute to a hub failure. (Photo: LAA Library)

'even when you do everything right, expect the unexpected' and, to extend this a little, 'a predilection to paranoia could be described as a healthy attribute among aviators.'

## LPIP, WHAT'S IT ALL ABOUT?

It's strange how an initially random set of letters can form itself into a meaningful phrase or word. Certainly 'el-pip' rolls off the tongue so it's a really good start for any potentially

long-lasting acronym. Even though I know what it means, I cannot help thinking, whenever I hear it, of a nine-year-old in a Stetson brandishing a toy Colt 45.

LPIP actually stands for Low-hours Propeller Inspection Protocol. It defines something of a departure from the normal rules of engagement for a manufacturer's overhaul, as generally automatically adopted by the aircraft industry and its administrative

support agencies, in our case, EASA and the UK CAA. LPIP focuses its attention on propeller overhaul but, in truth, heralds the arrival of a more 'appropriate' way of thinking when it comes to the imposition of mandatory service intervals, especially adapted for *Permit to Fly* types.

Until recently, the only approach to maintaining a constant-speed or variable-pitch propeller overhaul which was accepted by propeller manufacturers involved a regular total overhaul, irrespective of the number of hours flown. That was because the manufacturers, for good reasons, defined a calendar life. Once this life had been reached, regardless of the application, the part would need to be replaced or, more normally, overhauled to a standard set by the original manufacturer.

Although the aforementioned protocol proved fine for aircraft which rack up a lot of flying hours each year – for example, in a training role – the industry as a whole has long appreciated that a full overhaul isn't necessary for propellers which have reached their calendar life without accumulating many hours.

We're an Association which has always put our members' interests first, following our three fundamental aims: fun, affordable and safe flying for all. With these three objectives firmly in mind, LAA Engineering has worked with propeller overhaul companies and the authorities to develop a more appropriate maintenance regime for aircraft operating under our system.

When developing new maintenance rules, LAA Engineers, that's those based at HQ and the many highly-skilled personnel working on our behalf in the field, have to consider two key basic elements in coming to a decision. Firstly, the 'appropriateness of the requirements' and, secondly, the 'focused specificity' of them. From the human factors standpoint, if something isn't thought necessary, whatever it is, it won't be long before it disappears from view and, as a consequence, really important safety advice might be overlooked.

Let's look at the 'appropriateness' point first. As I say in the captions under the pictures, the propeller on (any) aircraft is one of the most hard-working components involved in flight operations. Only a fool would suggest or imply that this device needs no inspection or maintenance, but many have questioned – quite rightly, in my view – the need to complete a manufacturer's overhaul, which in effect is designed to bring the propeller back to an 'as new' state, on an example that hasn't done much work.

Essentially, there are three reasons to introduce a required inspection of any item fitted to an aircraft –; let's stick specifically to propellers. The first relates to checking that the parts in the propeller haven't cracked or worn below tolerance – for example, the blades haven't been 'dressed' beyond limits. This first reason deals with aspects which, under normal operational circumstances, relates to hours in service. This detailed check of all parts is the expensive part of a propeller overhaul because the individual parts often have to be stripped of paint or other protective coatings before measurement and costly non-destructive testing (NDT) checks are made.

The second reason for 'overhauling' a propeller is based on its calendar 'age'. Oils and greases degrade with time, as do most types of flexible seals, especially those made

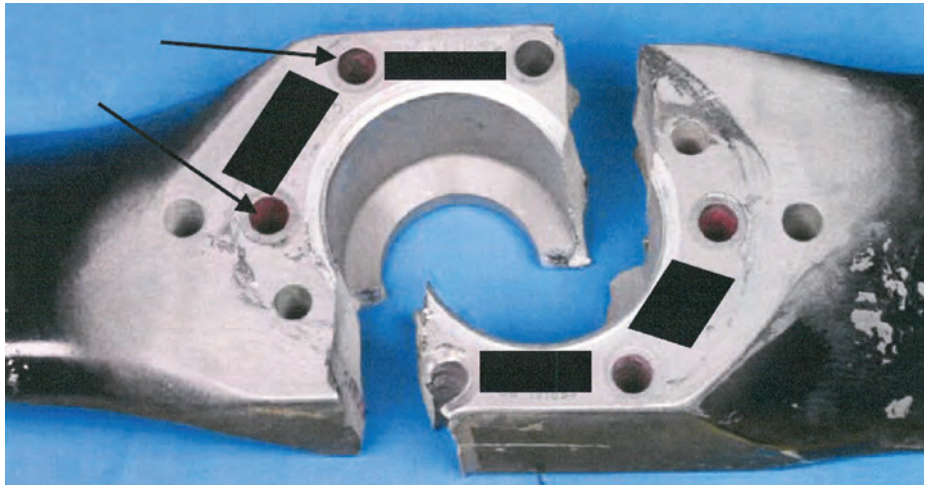

*(Top & above)* Although LPIP doesn't include fixed-pitch propellers, it doesn't mean that regular inspections aren't necessary, though they need to be appropriate for the actual prop type. This failed McCauley 1A170 propeller is a type similar to those fitted to quite a few LAA aircraft and, as you can see, it has suffered a catastrophic failure. Sadly, the failure occurred during a cross-country flight and the pilot and his passenger suffered serious 'life-changing' injuries after hitting trees during the ensuing forced landing.

There's a specific *Airworthiness Directive* requiring regular (every 200 hours) dye penetrant testing of these prop bosses. Though no LAA aircraft operate with this specific type, similar props are in service, so LAA Engineering is recommending that owners of all metal fixed-pitch propellers include a thorough visual inspection at each annual and consider removing the prop, perhaps every three years, to take a very close look at this critical component as part of their Tailored Maintenance Schedule. *(Photos: NTSB/FAA)*

from rubber compounds. And, importantly in this context, propellers which aren't used much are more prone to internal corrosion than their well-used cousins.

The third reason for the overhaul is that it provides an opportunity for specialist propeller engineers to check a propeller against the latest 'factory' standards – primarily but not solely to ensure that all *Airworthiness Directives (AD)* or *Factory Service Bulletins (SB)* which may have been published since it was first fitted to the aircraft, have been complied with and that it's in an acceptable configuration.

An LPIP inspection recognises that, although a propeller may have reached its calendar age, it mightn't have run for anything like its maximum 'operating hours' life. For instance, although an average variable-pitch prop will have a maximum allowable mechanical age of something in the order of two thousand hours, many LAA aircraft complete less than fifty hours per year – you can work out the maths for yourself. So there's a great disparity between an average six-year overhaul requirement and the mechanical age limit, in hours.

For propellers accepted into the LPIP scheme which are essentially in good order and have flown less than fifty per cent of their individual overhaul hours life, and are therefore unlikely to reach the manufacturer's 'hours' limits before the next calendar check, inspections related to wear usually aren't justified.

The LPIP inspection arrangements which have been negotiated thus far have been based upon existing actual manufacturer's

schedules. In the case of Hartzell propellers, for example, prop engineers use the 'return to service from long-term storage' inspection – it's nearly a perfect fit. Other types use different inspection models, but the principle is the same.

So far, three major UK specialist propeller companies have been trialling LPIP and the experiences of them, the LAA and our members have been extremely positive. We've created an *Airworthiness Alert* that offers a link to the latest *Technical Leaflet*, which gives contact details to the propeller companies who have joined the scheme. So, if your prop is overdue its calendar time for overhaul but remains well below its hours limit, then it'd be worth you looking at asking your propeller shop for an LPIP inspection. The company you use will first need to inspect the propeller before committing to this option but, if it's suitable, the cost should be considerably lower than that of a full manufacturer's overhaul.

#### **MCCAULEY 1A170 FIXED-PITCH PROP**

Although LPIP inspections don't involve fixed-pitch propellers it's important to recognise, taking into account the basic reasons for conducting it in the first place, the second reason for considering a different inspection regime for propellers, that being the 'focused requirements' necessarily defined in an *AD*.

As an aviator, you'll doubtless understand that *ADs* and *SBs* normally follow a field report of a specific failure – ie >



## SAFETY SPOT

this or that part has failed in service and the AD directs engineers towards a detailed inspection of aircraft containing it. Sometimes the AD will be a one-off inspection – perhaps, for example, when there's been a fitting error which has led to a failure. In that case, the check will be limited to ensuring the fitting error hasn't migrated across a fleet of identical parts.

Sometimes repetitive inspections may be required – perhaps a part has shown unpredicted wear in service – so regular checks are needed until the part has been replaced. Often, replacing the part will release the aircraft from the demands of the AD, and its maintenance record (and, in the sport aircraft arena, the logbook) will show the AD as being 'not applicable'.

There are a couple of negative human factors issues here. One is that technicians are taught that, 'If an AD doesn't apply don't waste time studying it'. I hear that all the time from tradespeople in the field, though not normally LAA Inspectors. Two, the specificity of the inspection, coupled with reason one, means an AD is in place because a failure of a component only involves that specific one, although there could be many other similar operating on aircraft, which are equally liable to fail but they won't be covered in the AD.

A good example of this, and one reason why the LAA prefers a rather broader brush, or cultural approach, to continuing airworthiness management, is the recent publication of an FAA *Special Airworthiness Information Bulletin*. This *Bulletin*, incidentally, has been reiterated as an *EASA Safety Information Bulletin*.

The origin for these two *Bulletins* was a very nasty accident which followed an in-flight failure of a McCauley propeller in the US, back in August 2017. The prop itself was subject to an AD (FAA AD 82-27-01) requiring NDT checks each 200 hours in service. The AD required the removal of the propeller and a close inspection for cracks around the attaching bolt holes. Naturally, cracks there could lead to a complete failure of the boss, and that's exactly what happened.

Although it isn't the primary point of this section, it seems that a look at the logbook of the aircraft in question confirmed that the required checks had been completed.

However, it seemed that, at some point in the past, a dye penetrant check had been undertaken using Type II material (visible under white light), which may have prevented the later Type I penetrant check (UV-visible) from working properly, possibly meaning that the cracks weren't seen and the prop was returned to service.

Now the both *Bulletins*, wisely, focus closely on the dangers of using Type II penetrant in this context but all this, to come back to the point, relates to one specific type of propeller: the McCauley 1A170/FFA.

Looking through our propeller approval list we can see that there are no FFA types in service on LAA aircraft but, taking the cultural (broad-brush) approach, we do see quite a few 1A170 props and, on the face of it, there doesn't seem to be that much difference between them.

I hope the above explains what the LAA's LPIP scheme is all about, taking into account that our shared management approach to continuing airworthiness is a jewel-in-the-crown for our Association's members.



(Above left & right) A full inspection of the undercarriage assembly on an aircraft isn't complete until the wheel has been fully checked. Like the propeller mentioned earlier, these essential components are so reliable that they're often completely ignored during regular maintenance inspections. Again, just like the prop, they're one of the hardest-working components on an aircraft and fully deserve time taken to keep them in tip-top condition.

This wheel, from a EuroFOX tug aircraft, failed during taxi after launching a glider – you can see that the failure sequence has started because of cracks which have originated at the wheel-half bolt attachment holes. (Photos: Malcolm McBride)

LPIP itself is on a pathway which will lead to checks of non-certified VP, ground-adjustable and fixed-pitch metal and wooden props, but for further information about that you'll have to watch this space! You can find the information about the US incident which led to the issue of the SAIB in an LAA *Airworthiness Alert* online. For now though, where's my Stetson?

### AEROTECHNIK WHEEL FAILURE: THE IMPORTANCE OF CHECKING UNDERCARRIAGES

I'll wrap this edition of *Safety Spot* up with three member-led stories about wheel failures.

The first, sent in by LAA Inspector Peter Claiden, relates to an unusual wheel failure event on a EuroFOX tug. Peter sent the wheel in to us for closer examination and I've included a couple of pictures to show what happened. Here's Peter's report.

*'Hi Malcolm, 'As discussed on the telephone earlier, the subject aircraft is approximately four years old and has flown around 800hr, almost exclusively as a glider tug off a grass runway, having made approximately 2,800 landings in that time. The failed wheel is an original fit, its partner having been replaced about two years ago due to cracks emanating from the bolt holes.*

*'This first replacement wheel has now been removed from service (two new wheels from EuroFOX now fitted) but on removal shows no signs of cracking. This recent failure occurred after landing when on the taxiway – the aircraft ended up running along on the inner wheel half-rim, there was no other damage.*

*'It should be noted that a loss of directional control on this grass runway could be critical as it's immediately adjacent to the taxiway!*

*'We've previously removed the spats from this aircraft and I've suggested that a close inspection of the wheel needs to be made at each DI.*

*'Best regards, Peter'*

The manufacturer of the EuroFOX chose the Aerotechnik wheel for its aircraft and, up until this week, this was the first wheel event featuring this marque we've ever received.

I'm sure you'd agree that 2,800 landings is a much higher than average number and, to be honest, I thought, taking into account the high usage, reproducing a picture in *Safety Spot* would suffice.

Then, shortly after this first report, I received an email from LAA'er Martyn Wilmington, which made me wonder whether I should re-calibrate my thoughts"

*'Malcolm, good morning, 'I have owned the EV-97 EuroStar for four years now and I've had the main undercarriage wheels off at least twice, for varying reasons.*

*'Recently, I decided to renew my main wheel tyres as they had started to show wear, so I purchased two nice new 'Aero Classics.' One side was removed and replaced with no problems.*

*'When removing the other side – tyre and tube out and cleaning up the wheel rim – a small fragment fell to the floor. I removed the inner wheel rim for further inspection and found that it was also cracked at this point. Looking more closely, I could see that the other two brake disc mounting holes are also cracked.*

*'My question is, do you think this was caused by corrosion between the securing bolt and the aluminium or a stress crack caused by past over-tightening?*

*'My concern is for the rest of the EV-97 fleet and should we warn them about this failure? I have since purchased and fitted a new wheel rim and also checked the other one very closely, which shows none of the signs of corrosion or cracking.*

*'Please see the photo attached.*

*'Yours, Martyn'*

So, two wheel failures within a short time is probably (hopefully) just a coincidence –





(Top & above) Initially, when we received the failed Aerotechnik wheel from a EuroFOX, I focused my attention on the failure point, the previously mentioned cracks. Then I received an email from LAA'er, Martyn Wilmington, detailing another failure, this time on an Aerotechnik wheel off an EV-97 EuroStar. In this later failure it looked like corrosion around the brake disk supports at the wheels rim, so I looked again at the EuroFOX wheel.

The uppermost picture shows the level of corrosion in this attachment, which was probably caused by dissimilar metals in close proximity. The picture above, meanwhile, shows the manufacturer's casting mark above a failed bolt hole.

(Photos: Malcolm McBride)

(Right) Just after a practice take-off, a student's instructor noticed that 'something didn't feel right'. After visually checking around the airframe, the student was horrified to see that the right mainwheel was just hanging onto its axle. The picture right shows the wheel after bringing the aircraft to a stop, while the one far right was shot after it'd been refitted, using all the required parts!

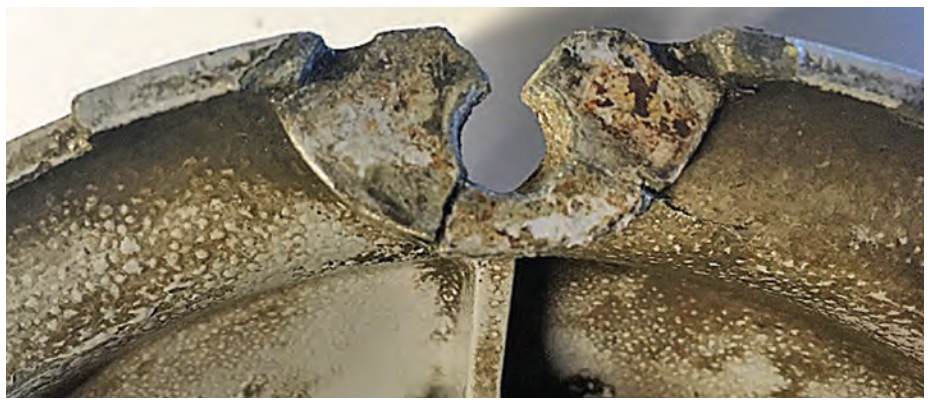

(Above) Here's what Martyn Wilmington found when he dismantled his wheel to fit new tyres. The failure of this attachment was most likely due to the electrolytic action because of the close proximity of steel (the brake disk attachment bolt) against aluminium alloy (the wheel half), aided and abetted no doubt by the various substances in the water splashed up during normal operation.

(Photo: Martyn Wilmington)

though, to answer Martyn's second question ('should we warn others?'), yes, that's why I've included his story in *Safety Spot*.

However, I wouldn't necessarily focus specifically on the Aerotechnik wheel as, like propellers, this component is often forgotten during an inspection. Owners will often 'pull' them to re-grease bearings, but how many regularly strip wheels into their components for a 'close-in' inspection and complete de-corrode?

During my training as an aero engineer, detailed wheel inspections figured high on the agenda during a big check, which normally took place on light aircraft every three years. Although most LAA aircraft don't complete anything like the number of hours flown by those in the commercial sector, it's still important to include complete component strip and refurbish tasks into a *Permit to Fly* type's Tailored Maintenance Schedule (TMS).

Of course, a detailed 'first flight of the day' pre-flight should also part of the TMS – it's always worth checking that the wheels aren't going to fall off during operation! One LAA'er and trainee pilot, and his instructor, narrowly missed becoming part of a runway excursion incident, here's his report.

'Malcolm,

'I'm the co-owner of a Rans S6-ES, which we purchased in October 2017, following a satisfactory *Permit to Fly* inspection. It has a

tricycle undercarriage and was fitted with optional spats. Both myself and the aircraft's co-owner are pupils 'under instruction'.

'On 18 May we cleaned the aeroplane and made a number of checks. My partner decided to remove the wheel spats, and the aircraft was next flown by me under instruction.

'We took-off from our home airfield and landed at a nearby strip a few minutes later (having flown a distance of about 7nm). I was undertaking Lesson 16.a. of the NPPL (M) Syllabus, Forced Landings.

'After landing we then took-off again. It was a zero-wind day so we took-off in the opposite direction to which we'd landed.

'Shortly after take-off, my instructor sensed that something wasn't right – he could feel an unusual vibration (I must say that I couldn't feel it). Looking around the aircraft, I was horrified to see the left-hand main landing wheel was just hanging on the end of its axle!

'The instructor decided that we must make an immediate landing back at Stoke Golding and I happily announced, "You have control!"

'He attempted to briskly roll the plane to the right, to see if this might encourage the wheel to slide back along the axle, but that didn't work. He then, skilfully, landed the plane safely by coming down as slowly as possible with the right wing low for as long as possible.

'We came to rest with the wheel still on the axle, but only just. The wheel was





## SAFETY SPOT

pushed back on the axle and the plane then rolled off the runway.

'Examination of the undercarriage showed that the wheel should sit on the axle and then two metal collars (or spacers) are placed over it.

'On the left side both of these spacers were missing. On the right, both were still in place and the wheel hadn't moved.

'It appears that, when taking the spats off, a bolt was removed from the end of the axle. What wasn't obvious was that this bolt not only held the spat in place but was also essential for the security of the wheel. As such, it should've been replaced, along with a washer to retain both the wheel and the spacer.

'My concerns are, firstly, that there's no warning in the manual, about both the spat and the wheel being secured by the Loctite on the outer spacer and bolt. Removal of the spat without replacement of the bolt and washer will mean that the wheel is no longer secure.

'Secondly, I feel that a simple bolt and washer, together with application of Loctite to the outer spacer, isn't a sufficiently secure fixing for such a safety-critical item. Surely, a locking mechanism, such as a split pin through the outer spacer and/or a locking washer or wiring around the bolt, would be better?

'And thirdly, if this could happen to us, it may to other Rans S6-ES owners, possibly with a more serious outcome.'

Well, this is the sort of experience that could put the wind up anybody and it isn't the first time wheels have come off because they haven't been securely fixed. The more experienced among you will recognise that, in fact, there have been a number of failures here, both inspection-related.

Of course, this lack of a fixing should have been spotted during the pre-flight inspection, so the question might be, 'who is responsible for this inspection?'

The answer is straightforward, of course, it was the qualified pilot – in this case, the instructor. Could it be that he trusted the owner of the aircraft, an inexperienced chap, rather too much and didn't complete a second walk-round?

The second inspection failing relates to the lack of a proper check after the spat was removed. In the LAA system, as with any involving the 'work done' on an aircraft, all completed tasks must be inspected, and that recorded, either on worksheets or in the aircraft's logbook.

A wheel removal and replacement can be completed and inspected by the owner/pilot, if they're qualified and feel competent to be able to confirm that the work done has been done correctly. This inspection privilege is defined in a *Technical Leaflet* in the LAA Library (*TL. 2. 05 – Pilot Authorised Maintenance*).

It isn't clear whether a work-pack was created for this spat removal job, but it is evident that the task, as carried out, wasn't subject to an appropriate inspection afterwards. It's a lack of qualified inspection which led to this close shave on landing – in other words, not just because the wheel wasn't attached correctly, but due to the fact that this error wasn't spotted.

Okay, lessons hopefully learnt. I think I'll put my feet up. Fair winds... ■



*(Top & above)* These two pictures serve to remind us about the need to recognise potential system failure modes on aircraft. That may sound a bit fanciful, but it's always worth thinking 'what if' when assembling any component part. Regular readers of *Safety Spot* will know that we've been highlighting a hinge failure which recently caused the partial detachment of a rudder on an early Piper Cub. Although this was the first record of an incident like this, it did highlight a previously un-spotted failure mode.

In the picture at top, note that the head of the hinge pin is smaller than the inside diameter of the knuckle, so the only thing holding the hinge assembly together is the friction in the interference fit of the inner bearing. Lose this friction, for any reason, and the hinge will fail. The picture above, meanwhile, shows a simple 'fix' – a thin washer fitted to the top and bottom of the pin – so, even if the bearing does become loose, the hinge pin cannot fall out. *(Photos: Malcolm McBride)*



CZAW SPORTCRUISER NOSELEGS

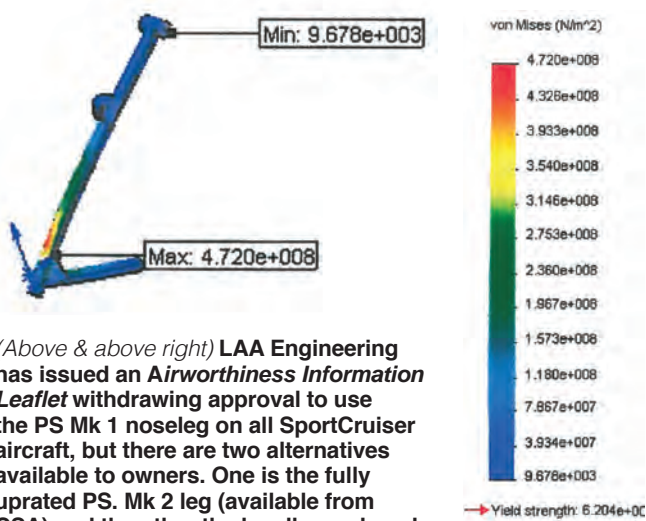

(Above & above right) LAA Engineering has issued an *Airworthiness Information Leaflet* withdrawing approval to use the PS Mk 1 noseleg on all SportCruiser aircraft, but there are two alternatives available to owners. One is the fully updated PS. Mk 2 leg (available from CSA) and the other the locally produced ‘updated’ version of the CZAW version.

These screenshots, submitted by the original designer of the leg strengthening mod, LAA’er, Tony Palmer, shows clearly where the maximum bending load is in this component. (Images: Tony Palmer)

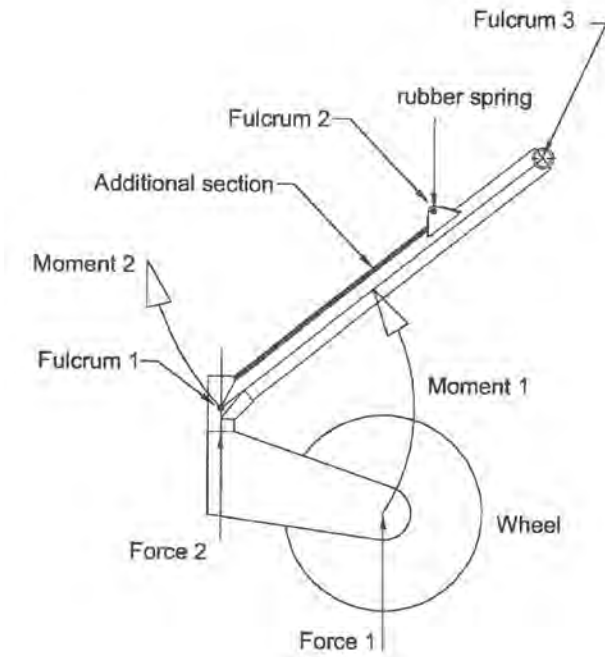

(Above) As part of the recent *Airworthiness Information Leaflet* withdrawing the PS Mk 1 noseleg from use on all UK SportCruisers, the LAA has taken the opportunity to review the maintenance/inspection requirements for them in rather more general terms.

The annual inspection now requires the spindle assembly to be dismantled, inspected, re-lubricated and re-tensioned. Many of these spindles have been in service for the last six years and, as you can see from this picture, some are suffering from the potentially weakening effect of corrosion. (Photo: Martin Ferrid)

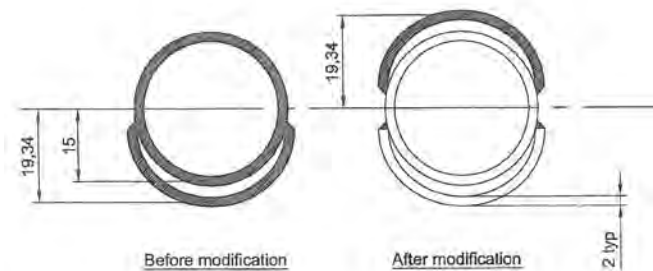

(Top & above) Tony Palmer enlisted the help of LAA Inspector Farry Sayyah to make a strengthened noseleg and quite a few SportCruisers have benefited from this less expensive alternative to the factory replacement part.

This strengthening mod is now a Standard Option for CZAW SportCruiser aircraft (as listed in the TADS) so ‘sign out’ can be done by an LAA Inspector (without reference to HQ). These pictures show how the leg has been strengthened. (Images: Tony Palmer/Farry Sayyah)

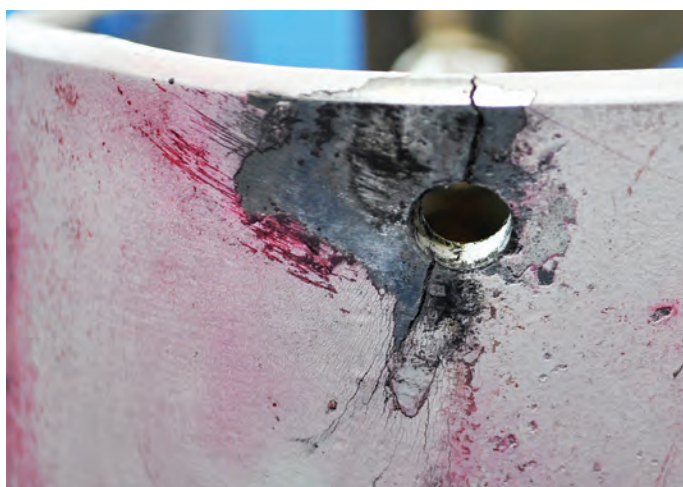

(Above & above right) LAA Inspector, Graham Smith has developed a stronger version of SportCruiser nosewheel fork. Regular readers will know that the original ‘two-leaf’ design has been suffering cracking, originating from the attachment holes, as shown in the the picture above left, which has led to an increased inspection requirement (every fifty hours).

The photo above right, meanwhile, shows the updated noseleg fork – notice that it now has three leaves. This three-leaf fork is available from Graham, and its fitment removes the fifty-hour inspection interval. Many owners have taken advantage of this ‘LAA Home-Grown’ replacement part, for which replacement is covered by a *Standard Modification (SM 13680)* – details on the LAA Website. (Photos: Graham Smith/John Tiley)





(Left) Although SportCruisers have been grabbing all the headlines when it comes to noseleg issues, it should be noted that all nosewheel types need careful (and regular) detailed inspections. The noselegs on most LAA types aren't designed to take the punishment which some of the other in-service training aircraft (like the PA-28 or the C-150) are able to withstand.

This picture shows a fairly typical overload failure, along the edge of a weld in the support flange of a DynAero MCR-01 Club noseleg. Luckily, this failure was spotted by the diligent owner, Peter Milward, during a pre-flight inspection so it didn't end up as being the cause of a collapse on landing or take-off. (Photo: Peter Milward)



(Above) Whatever aircraft you fly, it's vitally important that its undercarriage is inspected before every flight, and a detailed inspection of the whole assembly is carried out regularly, as part of your Tailored Maintenance Schedule. Noseleg failures almost always involve extremely expensive repairs – firstly, there's the inevitable engine shock load inspection, then there's normally a new propeller, plus, of course, repairs to the lower forward fuselage structure, which, if you're very unlucky can include a firewall replacement.

There's perhaps an even more important reason to keep an eye on things – during this failure, the leg itself has broken through into the cockpit! As you can see, the part has ended up very close to the pilot's feet, which is potentially more life-changing than a dent in the bank balance. (Photo: Swiss TSB)

## LAA ENGINEERING CHARGES – PLEASE NOTE, NEW FEES HAVE APPLIED SINCE 1 APRIL 2015

### LAA Project Registration

Kit Built Aircraft	£300
Plans Built Aircraft	£50

### Issue of a *Permit to Test Fly*

Non-LAA approved design only	£40
------------------------------	-----

### Initial *Permit* issue

Up to 450kg	£450
451-999kg	£550
1,000kg and above	£650

### *Permit Renewal* (can now be paid online via LAA Shop)

<b>Up to 450kg</b>	<b>£155</b>
<b>451-999kg</b>	<b>£200</b>
<b>1,000kg and above</b>	<b>£230</b>

**Factory-built gyroplanes (all weights) Note: if the last *Renewal* wasn't administered by the LAA an extra fee of £125 applies**

### Modification application

Prototype modification	minimum £60
Repeat modification	minimum £30

### Transfer

(from C of A to *Permit* or CAA *Permit* to LAA *Permit*)

Up to 450kg	£150
451-999kg	£250
1,000kg and above	£350

### Four-seat aircraft

Manufacturer's/agent's type acceptance fee	£2,000
Project registration royalty	£50

### Category change

Group A to microlight	£135
Microlight to Group A	£135

### Change of G-Registration fee

Issue of <i>Permit</i> documents following G-Reg change	£45
---	-----

### Replacement Documents

Lost, stolen etc (fee is per document)	£20
--	-----

*Latest SPARS – No 17 April 2018*

**PLEASE NOTE: When you're submitting documents using an A4-sized envelope, a First Class stamp is insufficient postage.**