



PITCH TRIM
Service Manual

PIPER AIRCRAFT CORPORATION

**PIPER AIRCRAFT CORPORATION
LOCK HAVEN, PENNSYLVANIA 17745**

**THIS SERVICE MANUAL SUPERSEDES ALL PREVIOUS PITCH TRIM
SERVICE MANUALS ISSUED PRIOR TO AUGUST 1972.**

**Published by
PUBLICATIONS DEPARTMENT
Piper Aircraft Corporation
753 771
Issued: March 1970
Reissued: August 1972**

REVISIONS ISSUED

Current, permanent and temporary revisions to this Pitch Trim Service Manual reissued August 1972 are as follows:

753 771 (PR730228)	Permanent Revision	Dated February 28, 1973
753 771 (PR731109)	Permanent Revision	Dated November 9, 1973
753 771 (PR750603)	Permanent Revision	Dated June 3, 1975
753 771 (PR760712)	Permanent Revision	Dated July 12, 1976
753 771 (PR770225)	Permanent Revision	Dated February 25, 1977
753 771 (PR771220)	Permanent Revision	Dated December 20, 1977

FOREWORD

This service manual is provided as a guide for installing, servicing and maintaining all Electric Pitch Trim Systems used in Piper airplanes.

The information presented in this manual has been divided into four parts, each consisting of six (6) sections. An index is located in the front of the manual and preceding each section to provide a quick reference.

The information compiled in this manual will be kept current by revisions distributed to the manual owners through their local Piper Dealer or Distributor.

REVISION

There will be two (2) types of revisions used to keep this manual current. The material compiled in these revisions will consist of information necessary to maintain the present equipment, therefore, it is imperative that this material be inserted in the service manual at the time it is received.

I. Temporary Revision

This type revision will be distributed at anytime it is necessary to forward Technical Servicing Information to the field. The temporary revision will usually consist of one or two pages which may be inserted in the front of the manual. These revisions will include deletions and additions of material pertinent to different paragraphs of the service manual, therefore, when the temporary revision is received, review the manual and mark the affected paragraph with the code date of the latest revision for a ready reference.

II. Permanent Revision

This type revision will supersede all previous temporary revisions. These revisions will be of complete page replacement and shall be inserted in the service manual as per the instructions given below.

1. Replace the obsolete pages with revised pages of the same page number.

2. Insert pages with page numbers followed by a small letter in direct sequence with the same common page number.

3. Insert pages with page numbers followed by a capital letter in direct sequence with the same common page number but after any pages with the same common page number followed by a small letter.

III. Identification of Revised Material

Revised text and illustrations shall be indicated by a black vertical line along the left hand margin of the page opposite the change. A line opposite the page number or section title and printing date will indicate that the text or illustration was unchanged, but the material was relocated to a different page. Newly added material shall be identified by an arrow pointing toward either the text, text heading or illustration. When material is removed, an arrow will point away from the area from which the material was removed.

Symbols will indicate only current revisions with changes and additions to or deletions of existing text and illustrations. Changes in capitalization, spelling, punctuation or the physical location of the material on the page will not be identified by symbols.

TABLE OF CONTENTS

PART I

P.E.T. (PIPER ELECTRIC TRIM) SYSTEMS

PA-28 and PA-32 Series; PA-24, PA-30 and PA-39 Series; and PA-23 Series

I	INTRODUCTION AND DESCRIPTION	1-1
II	THEORY OF OPERATION	2-1
III	REMOVAL AND INSTALLATION	3-1
IV	ADJUSTMENT PROCEDURES AND OPERATIONAL CHECKS	4-1
V	TEST EQUIPMENT	5-1
VI	SCHEMATICS	6-1

PART II

ALTIMATIC III, IIIB and IIIB-I ELECTRIC TRIM SYSTEMS

VII	INTRODUCTION AND DESCRIPTION	7-1
VIII	THEORY OF OPERATION	8-1
IX	REMOVAL AND INSTALLATION	9-1
X	ADJUSTMENT PROCEDURES AND OPERATIONAL CHECKS	10-1
XI	TEST EQUIPMENT	11-1
XII	SCHEMATICS	12-1

TABLE OF CONTENTS (Cont.)

PART III

M.E.T. (MANUAL ELECTRIC TRIM) SYSTEMS

PA-23-250; PA-24, PA-30 and PA-39 and PA-34 Series

XIII	INTRODUCTION AND DESCRIPTION	13-1
XIV	THEORY OF OPERATION	14-1
XV	REMOVAL AND INSTALLATION	15-1
XVI	ADJUSTMENT PROCEDURES AND OPERATIONAL CHECKS. . .	16-1
XVII	TEST EQUIPMENT	17-1
XVIII	SCHEMATICS	18-1

PART IV

ALTIMATIC III, IIIB and IIIB-I ELECTRIC TRIM SYSTEMS

(DUAL CONTACT TYPE TRIM SENSOR)

PA-23-250 (Six Place)

XIX	INTRODUCTION AND DESCRIPTION	19-1
XX	THEORY OF OPERATION	20-1
XXI	REMOVAL AND INSTALLATION	21-1
XXII	ADJUSTMENT PROCEDURE AND OPERATIONAL CHECKS . .	22-1
XXIII	TEST EQUIPMENT	23-1
XXIV	SCHEMATICS	24-1

NOTE

Refer to appropriate AFCS Service Manuals for all other Electric Trim System information.

LIST OF ILLUSTRATIONS

Figure		Page
2-1.	Servo Selector Switch Chain Type Pitch Servo	2-8
2-2.	Servo Selector Switch Rack and Pinion Pitch Servo	2-8
2-3.	Plate Sensor Equal Elevator or Stabilator Cable Tension	2-9
2-4.	Plate Sensor Unequal Elevator or Stabilator Cable Tension	2-9
2-5.	Pendulous Sensor Equal Elevator or Stabilator Cable Tension	2-10
2-6.	Pendulous Sensor Unequal Elevator or Stabilator Cable Tension	2-10
3-1.	Servicing Aids	3-1
3-2.	Typical Stabilator Holding Fixture	3-2
3-3.	PA-23-250, PA-24 and PA-30 Trim Servo Cable Routing	3-7
3-4.	PA-23-250, PA-24 and PA-30 Pendulous Trim Sensor	3-7
3-5.	PA-23-250, PA-24 and PA-30 Positioning and Alignment of Plate Type Trim Sensor	3-8
3-6.	PA-28 Trim Servo Cable Routing	3-8
3-7.	PA-28 and PA-32 Trim Servo Cable Routing	3-19
3-8.	Plate Sensor with Amplifier	3-20
3-9.	Pendulous Sensor with Amplifier	3-20
3-10.	Electric Trim Stop Sensor Assembly Installation (PA-28-181, PA-32R-300, PA-32RT-300 and PA-32RT-300T)	3-22
4-1.	P. E. T. Trim Servo Clutch Adjustment	4-5
4-2.	Switch Adjustment Cams	4-5
4-3.	PA-23-250, PA-24 and PA-30 P. E. T. -1 Manual Electric Trim Control Wheel Switch	4-6
4-4.	PA-23-250, PA-24 and PA-30 P. E. T. -1 Manual, P. E. T. -1 Automatic and P. E. T. -2 Automatic Electric Trim Control Wheel Switch	4-6
4-5.	PA-28 and PA-32 Manual Electric Trim Control Wheel Switch	4-6a/4-6b
4-6.	Electric Trim Stop Sensor Assembly	5-2
5-1.	Test Equipment	5-2
6-1.	P. E. T. Series Pitch Trim Servo Motor Windings	6-2
6-2.	P. E. T. -1 Manual Electric Trim Schematic	6-2
6-3.	P. E. T. -1 Automatic Electric Trim Schematic	6-3
6-4.	P. E. T. -2 Automatic Electric Trim Schematic	6-4
6-5.	P.E.T.-1 Manual Electric Trim Schematic (Electric Trim Stop Sensor PA-28-181, PA-32R-300, PA-32RT-300 and PA-32RT-300T)	6-5
6-6.	P. E. T. -1 Manual Electric Trim Schematic	6-5
8-1.	Plate Sensor Equal Elevator or Stabilator Cable Tension	8-5
8-2.	Plate Sensor Unequal Elevator or Stabilator Cable Tension	8-5
8-3.	Pendulous Sensor Equal Elevator or Stabilator Cable Tension	8-6

LIST OF ILLUSTRATIONS (cont.)

Figure		Page
8-4.	Pendulous Sensor Unequal Elevator or Stabilator Cable Tension . . .	8-6
9-1.	Servicing Aids	9-1
9-2.	Typical Stabilator Holding Fixture	9-2
9-3.	PA-23-250, PA-24, PA-30 and PA-39 Trim Servo Cable Routing . . .	9-9
9-4.	PA-23-250, PA-24, PA-30, PA-31P, PA-34-200 and PA-39 Trim Sensor	9-9
9-5.	PA-31 Trim Servo Cable Routing	9-10
9-6.	PA-31 and PA-31-350 Trim Servo Cable Routing	9-10
9-7.	PA-31 and PA-31-350 Pendulous Trim Sensor	9-17
9-8.	PA-31P Trim Servo Cable Routing	9-17
9-9.	PA-31P Trim Servo Amplifier Replacement	9-19
9-10.	PA-32 Trim Servo Cable Routing	9-19
9-11.	Trim Servo Amplifier Replacement (1D345)	9-20
9-11a.	PA-23-250, PA-24, PA-30, PA-31, PA-31-350, PA-31P and PA-39 Trim Warning System	9-26a
9-12.	Plate Sensor Without Amplifier	9-26b
9-13.	Pendulous Sensor Without Amplifier	9-26b
9-14.	PA-34-200 Trim Servo Cable Routing	9-28
10-1.	III Series Trim Servo Clutch Adjustment	10-3
10-2.	Clutch and Clutch Solenoid Coil Adjusting Details	10-4
10-3.	Switch Adjustment Cams	10-7
10-4.	PA-23-250, PA-24 and PA-30 AltiMatic II	10-7
10-5.	PA-23-250 AltiMatic III	10-8
10-6.	PA-23-250 AltiMatic III B	10-8
10-7.	PA-23-250, PA-24 and PA-30 AltiMatic III	10-9
10-8.	PA-24 and PA-30 AltiMatic III	10-9
10-9.	PA-24, PA-30 and PA-39 AltiMatic III B	10-10
10-10.	PA-32 AltiMatic III	10-10
10-11.	PA-31 AltiMatic III and AltiMatic III B (With Trim Relay)	10-11
10-12.	PA-31 and PA-31P AltiMatic III B (Without Trim Delay)	10-11
10-13.	PA-24-260 and PA-39 AltiMatic III B-1	10-11a
10-14.	PA-31 and PA-31P AltiMatic III B-1	10-11a
10-15.	PA-31-350 AltiMatic III B-1	10-11b
10-16.	PA-34-200 AltiMatic III B-1	10-11b
11-1.	Test Equipment	11-2
11-2.	Trim Servo Test Plug, Piper P/N 757 299	11-2
12-1.	III Series Automatic Pitch Trim Servo Motor	12-1
12-2.	III Series Automatic Electric Trim Schematic AltiMatic II AutoPilot	12-3

LIST OF ILLUSTRATIONS (cont.)

Figure		Page
12-3.	III Series Automatic Electric Trim Schematic (Without Trim Relay) AltiMatic III and III B AutoPilots	12-4
12-4.	III Series Automatic Electric Trim Schematic (With Trim Relay), PA-31 Serial Nos. 31-1 to 31-424	12-5
12-5.	III Series Automatic Electric Trim Schematic AltiMatic III and III B AutoPilots	12-6
12-6.	III Series Automatic Electric Trim Schematic AltiMatic III B-1 AutoPilots	12-7
12-7.	III Series Automatic Electric Trim Schematic AltiMatic III B-1 AutoPilots, PA-34-200	12-8
12-8.	III Series Automatic Electric Trim Schematic AltiMatic III B-1 AutoPilots, PA-31-350	12-9
15-1.	Servicing Aids	15-2
15-2.	PA-23-250, PA-24-260, PA-30 and PA-39 Trim Servo Cable Routing	15-3
15-3.	PA-34-200 and PA-34-200T Trim Servo Cable Routing	15-5
16-1.	M. E. T. - 3 Trim Servo Clutch Adjustment	16-2
16-2.	Clutch Adjustment Detail	16-3
16-3.	PA-23-250 M. E. T. - 3, Control Wheel Switch	16-4
16-4.	PA-24-260, PA-30, PA-39 M. E. T. - 3, Control Wheel Switch	16-5
16-5.	PA-34-200 and PA-34-200T M. E. T. - 3, Control Wheel Switch	16-5
18-1.	M. E. T. - 3 Series Pitch Trim Servo Motor	18-1
18-2.	M. E. T. - 3 Manual Electric Trim Schematic, PA-23-250, PA-24-260, PA-30 and PA-39	18-2
18-3.	M. E. T. - 3 Manual Electric Trim Schematic, PA-34-200 and PA-34-200T	18-2
20-1.	Plate Sensor (Dual Contact) Equal Stabilator Cable Tension	20-3
20-2.	Plate Sensor (Dual Contact) Unequal Stabilator Cable Tension	20-3
21-1.	Servicing Aids	21-1
21-2.	Typical Stabilator Holding Fixture	21-2
21-3.	PA-23-250 Trim Servo Cable Routing	21-5
21-4.	PA-23-250 Dual Contact Type Trim Sensor	21-6
21-5.	Dual Contact Type Trim Sensor	21-8
22-1.	III Series Trim Servo Clutch Adjustment	22-2
22-2.	Clutch Adjustment Detail	22-3
22-3.	PA-23-250 AltiMatic III B-1	22-4
23-1.	Test Equipment	23-2
24-1.	III Series Automatic Pitch Trim Servo Motor	24-1
24-2.	III Series Automatic Electric Trim Schematic (Dual Contact Type Trim Sensor) AltiMatic III B-1 AutoPilots, PA-23-250	24-3

LIST OF TABLES

Table		Page
II-I.	Simplified Block Diagram P. E. T. Series Electric Pitch Trim Systems	2-6
II-II.	Identifying Features P. E. T. Series Electric Pitch Trim Systems	2-7
III-I.	Trim Servo Cable Tension	3-21
III-II.	Trim Sensor Cable Tension	3-21
VIII-I.	Simplified Block Diagram III Series Automatic Electric Pitch Trim System	8-4
VIII-II.	Identifying Features III Series Automatic Electric Pitch Trim System	8-4
IX-I.	Trim Servo Cable Tension	9-27
IX-II.	Trim Sensor Cable Tension	9-27
X-I.	III Series Trim Servo Clutch Tension	10-3
XIV-I.	Simplified Block Diagram M. E. T. Series Electric Pitch Trim System	14-2
XIV-II.	Identifying Features M. E. T. Series Electric Pitch Trim System	14-2
XV-I.	Trim Servo Cable Tension	15-4
XVI-I.	M. E. T. Series Trim Servo Clutch Tension	16-2
XVII-I.	Servo Continuity Test	17-2
XXI-I.	Trim Servo Cable Tension	21-5
XXI-II.	Trim Sensor Cable Tension	21-5
XXII-I.	III Series Trim Servo Clutch Tension	22-2

PART I

P.E.T.

(PIPER ELECTRIC TRIM)

SYSTEMS

SECTION I

INTRODUCTION AND DESCRIPTION

Paragraph		Page
1-1.	Introduction	1-1
1-2.	Description	1-1

SECTION I

INTRODUCTION AND DESCRIPTION

1-1. INTRODUCTION. This part of the service manual is divided into six sections. Section I contains a description of the P. E. T.-1 and P. E. T.-2 Electric Trim Systems. P. E. T. is the abbreviation for Piper Electric Trim which is designed and manufactured at Piper Aircraft Corporation, Vero Beach, Florida. Section II, Theory of Operation, explains the modes of operation. Section III, Removal and Installation, provides the information necessary for removal and installation of all trim components. Section IV, Adjustment Procedures and Operational Checks, provides the information necessary to check the operation of the system and perform minor adjustments. Section V, Test Equipment, provides the equipment required to center the trim sensor. Section VI, Schematics, provides the schematics of the trim systems for troubleshooting purposes.

1-2. DESCRIPTION. There are two types of Electric Pitch Trim Systems used to trim the pitch axis of the airplane electrically, manual and automatic. The P. E. T. systems discussed in Section I are: P. E. T.-1 Manual, P. E. T.-1 Automatic and P. E. T.-2 Automatic Pitch Trim Systems. The operation of these systems will be explained in Section II. When servicing the Piper Electric Pitch Trim Systems, the serviceman must determine which system is installed in the airplane being serviced to determine the service procedures to be used. The following description of each system will assist the serviceman in determining which system is installed in a particular airplane.

a. P. E. T.-1 MANUAL ELECTRIC PITCH TRIM SYSTEM. The P. E. T.-1 Manual Trim System is available for use anytime an AltiMatic AutoPilot is not installed.

b. P. E. T.-1 AUTOMATIC ELECTRIC PITCH TRIM SYSTEM. (Push button system.) The P. E. T.-1 Automatic Trim System is the only Piper Electric Trim System which employs a push button on the control wheel. This Pitch Trim System has a manual mode and an automatic mode of operation and incorporates the use of a pitch servo selector switch to determine which mode of trim operation is in use.

c. P. E. T.-2 AUTOMATIC ELECTRIC PITCH TRIM SYSTEM. The P. E. T.-2 Automatic Trim System has a manual mode and an automatic mode of operation and incorporates the use of a pitch servo selector switch to determine which mode of trim operation is in use. The P. E. T.-2 Trim servo has the addition of a relay to incorporate the use of a toggle switch in place of the pushbutton switch.

NOTE

A simplified block diagram in Table II-I and an identifying features diagram in Table II-II is presented in Section II of this manual. These diagrams illustrate the basic components and features of the P. E. T.-1 Manual, P. E. T.-1 Automatic and the P. E. T.-2 Automatic Electric Pitch Trim Systems.

SECTION II

THEORY OF OPERATION

Paragraph		Page
2-1.	Description	2-1
2-2.	P. E. T.-1 Manual Electric Trim System	2-2
2-3.	P. E. T.-1 Automatic Electric Trim System	2-2
2-4.	P. E. T.-2 Automatic Electric Trim System	2-4

SECTION II

THEORY OF OPERATION

2-1. DESCRIPTION. P. E. T. is an abbreviation for Piper Electric Trim which is designed and manufactured at Piper Aircraft Corporation, Vero Beach, Florida. The types of P. E. T. Electric Pitch Trim Systems installed in Piper airplanes are: P. E. T. -1 Manual, P. E. T. -1 Automatic and P. E. T. -2 Automatic. The operation of each system is explained in the following paragraphs. All Automatic Electric Pitch Trim Systems have a manual mode and an automatic mode of operation. The manual mode of all Automatic Electric Pitch Systems is operational only when the pitch axis of the AutoPilot is disengaged and the automatic mode of all Automatic Electric Pitch Trim Systems is operational when the pitch axis of the AutoPilot is engaged. Engaging the pitch axis of the AutoPilot, switches the pitch trim system from the manual mode to the automatic mode while disengaging the pitch portion of the AutoPilot switches the pitch trim system from the automatic mode to the manual mode. The micro switch that controls the mode of trim operation is located on the Pitch AutoPilot Servo as shown in illustration form, (Refer to Figure 2-1 and 2-2). Simplified block diagrams of the P. E. T. pitch trim systems are shown in Table II-I.

A differential cable tension sensing mechanism known as a Trim Sensor is incorporated in the various Automatic Electric Pitch Trim Systems installed in Piper airplanes. There are two types of trim sensors installed in Piper airplanes, plate type and pendulous type. The trim sensor consists of a set of adjustable electrical contacts which, when actuated by unequal elevator or stabilator cable tension, completes an electrical circuit in the trim amplifier. The trim amplifier converts the trim sensor signals into electrical power sufficient to drive the DC trim servo motor in the proper direction to correct an out of trim condition. The centering adjustment of the trim sensor contacts is of prime importance since the operation of the P. E. T. -1 Automatic Electric Pitch Trim System and the automatic mode of the P. E. T. -2 Automatic Electric Pitch Trim System is dependent on the centering adjustment of the trim sensor. The reaction of the sensor contacts to both equal and unequal elevator or stabilator control cable tension is shown in illustration form, see Figure 2-3 thru 2-6. A detailed procedure on trim sensor centering is contained in Section III, paragraph 3-22.

Stabilator or elevator control cable tension is very important for the correct operation of the trim sensor. Low cable tension can cause insensitive trim

sensor action and high cable tension can cause oversensitive trim sensor action. A substantial decrease in temperature can cause a decrease in cable tension, while a substantial increase in temperature can cause an increase in cable tension. This is caused by the unequal coefficient of expansion between the aluminum in the airplane structure and the steel control cables. It is recommended that temperature be considered when adjusting or checking control cable tension, to insure that the control cable tension will remain within the tolerance specification published in the appropriate Airframe Service Manual. The high portion of the control cable tension specification should be used when checking or setting the control cable tension during extremely high temperatures. The low portion of the control cable tension specification should be used when checking or setting the control cable tension during extremely low temperatures. This procedure will insure that the control cable tension will remain within the control cable tension specification for temperature variations.

2-2. P. E. T. -1 MANUAL ELECTRIC TRIM SYSTEM. The P. E. T. -1 Manual Electric Pitch Trim System is available for use anytime an AltiMatic AutoPilot is not installed, as shown in Table II-I. Trim is accomplished by the pilot actuating the trim switch on the control wheel which is a three position switch, spring loaded to the center or OFF position. When the trim switch is moved to the forward position, it completes a circuit to the servo motor, supplying voltage to the proper field winding to assure rotation of the motor in the correct direction. At the same time, the trim switch supplies electrical power to the clutch solenoid which engages the servo motor to the capstan through the clutch in the trim servo. Since the trim system cables are wrapped around the capstan, any rotation of the trim servo motor results in a change of position of the airplane's trim system, thus deflecting the stabilator or elevator trim tab in the conventional manner. When the human pilot releases the switch, it returns to the OFF position and electrical power is then disconnected from the trim servo motor and the clutch solenoid which completely disengages the electric pitch trim servo motor from the airplane's trim system cables. If the switch is moved to the rear position, the same events occur except the voltage is applied to the opposite field winding, insuring the opposite direction of rotation.

2-3. P. E. T. -1 AUTOMATIC ELECTRIC TRIM SYSTEM. This system has a manual mode and an automatic mode of operation and is the only Piper Electric Pitch Trim System which employs a push button on the control wheel. The P. E. T. -1 Automatic Electric Pitch Trim System incorporates the use of a pitch servo selector switch to determine which mode of trim operation is in use. In the AltiMatic II AutoPilot, the servo selector switch is located on the Auto-

Pilot pitch servo as shown in Figure 2-1 and 2-2. This system has a trim sensor with an amplifier attached, which operates the trim servo motor. The trim sensor and amplifier are operational when the push button is depressed in the manual mode and when the pitch axis of the AutoPilot is engaged. The difference between the automatic mode and the manual mode, is that in the manual mode, the pilot must depress the push button switch to allow the trim sensor and amplifier to correct an out of trim condition.

a. P. E. T.-1 AUTOMATIC ELECTRIC TRIM SYSTEM—MANUAL MODE. This mode applies to the trim system when the pitch axis of the AutoPilot is disengaged. Pitch trim can be accomplished electrically by the use of the push button on the pilot's control wheel. When the push button is depressed, the clutch solenoid is engaged and electrical power is applied to the trim amplifier. If at this time the "Trim Sensor" detects a differential in stabilator or elevator cable tension caused by an out of trim condition, the trim sensor mechanically actuates a set of electrical contacts. These contacts complete an electrical circuit in the trim amplifier which converts the trim sensor signals into electrical power sufficient to drive the DC trim servo motor. Due to the fact that the airplane's trim system cables are wrapped around the capstan, any rotation of the trim servo motor results in a change of position of the airplane's trim system, retrimming the control surface trim tab in the conventional manner. Repositioning of the control surface trim tab is reflected back to the trim sensor through the stabilator or elevator control cables. The trim sensor, sensing that the stabilator or elevator control cable tension is equal, signals the trim amplifier to shut off power to the trim servo motor. After establishing any pitch attitude, the pilot can depress the push button and the electric trim will relieve the control pressure.

b. P. E. T.-1 AUTOMATIC ELECTRIC TRIM SYSTEM—AUTOMATIC MODE. When the pitch axis of the AutoPilot is engaged, the push button on the pilot's control wheel is inoperative and electrical power is applied to the trim amplifier pitch trim servo clutch solenoid by the servo selector switch. When the trim sensor detects a differential in stabilator or elevator cable tension caused by an out of trim condition, the trim sensor actuates a set of electrical contacts. These contacts complete an electrical circuit in the trim amplifier which converts the trim sensor signals into electrical power sufficient to drive the DC trim servo motor.

NOTE

The clutch solenoid will maintain engagement of the servo motor and capstan gears continuously while the pitch axis of the AutoPilot is engaged.

Due to the fact that the airplane's trim system cables are wrapped around the capstan, any rotation of the trim servo motor results in a change of position of the airplane's trim system retrimming the control surface trim tab in the conventional manner. Repositioning of the control surface trim tab is reflected back to the trim sensor through the stabilator or elevator control cables. The trim sensor, sensing that the stabilator or elevator control cable tension is equal, signals the trim amplifier to shut off power to the trim servo motor. This trim condition remains constant until some new load appears on the stabilator or elevator through normal flight conditions, at which time the automatic trim operation is repeated.

2-4. P.E.T.-2 AUTOMATIC ELECTRIC TRIM SYSTEM. This pitch trim system has a manual mode and an automatic mode of operation. The P.E.T.-2 Automatic Pitch Trim System incorporates the use of a pitch servo selector switch to determine which mode of trim operation is in use. In the AltiMatic II AutoPilot, the servo selector switch is located on the AutoPilot pitch servo as shown in Figures 2-1 and 2-2. In the manual mode, pitch trim is accomplished by the pilot actuating the trim switch on the control wheel which is a three position switch, spring-loaded to the center or OFF position. In the automatic mode, the trim switch is inoperative and electric power is supplied to the trim amplifier by the servo selector switch on the AutoPilot Pitch servo. The trim amplifier and trim sensor utilized in the automatic mode only. Both modes are explained in the following paragraphs.

a. P.E.T.-2 AUTOMATIC ELECTRIC TRIM SYSTEM — MANUAL MODE. This mode applies to the Trim Systems when the pitch axis of the AutoPilot is disengaged. Pitch trim must be accomplished by the human pilot, either by the use of the manual trim crank, wheel or electrically by the use of the trim switch on the pilot's control wheel which is a three position switch, spring-loaded to the center or OFF position. When the trim switch is moved to the forward position, it completes a circuit to the servo motor, supplying voltage to the proper field winding to assure rotation of the motor in the correct direction. At the same time, the switch supplies electrical power to the clutch solenoid, which engages the motor to the capstan through the clutch on the trim servo. Since the trim system cables are wrapped around the capstan, any rotation of the trim servo motor results in a change of position of the airplane's trim system, thus deflecting the stabilator or elevator trim tab in the conventional manner. When the human pilot releases the switch, it returns to the OFF position and power is then disconnected from the trim servo motor and the clutch solenoid which completely disengages the Electric Pitch Trim Servo Motor from the airplane's trim system cables. If the switch is moved to the rear position, the same events occur ex-

cept voltage is applied to the opposite field winding, insuring the opposite direction of rotation.

b. P.E.T.-2 AUTOMATIC ELECTRIC TRIM SYSTEM—AUTOMATIC MODE. When the pitch axis of the AutoPilot is engaged, the switch on the pilot's control wheel is inoperative and electrical power is applied to the trim amplifier and pitch trim servo clutch solenoid by the servo selector switch. When the trim sensor detects a differential in stabilator or elevator cable tension caused by an out of trim condition, the trim sensor mechanically actuates a set of electrical contacts. These contacts complete an electrical circuit in the trim amplifier which converts the trim sensor signals into electrical power sufficient to drive the DC trim servo motor.

NOTE

The clutch solenoid will maintain engagement of the servo motor and capstan gears continuously while the pitch axis of the AutoPilot is engaged.

Due to the fact that the airplane's trim system cables are wrapped around the capstan, any rotation of the trim servo motor results in a change of position of the airplane's trim system, retrimming the control surface trim tab in the conventional manner. Repositioning of the control surface trim tab is reflected back to the trim sensor through the stabilator or elevator control cables. The trim sensor, sensing that the stabilator or elevator control cable tension is equal, signals the trim amplifier to shut off power to the trim servo motor. The trimmed condition remains constant until some new load appears on the stabilator or elevator through normal flight conditions, at which time the automatic trim operation is repeated.

PIPER PITCH TRIM SERVICE MANUAL

TABLE II-I. SIMPLIFIED BLOCK DIAGRAM
P.E.T. SERIES ELECTRIC PITCH TRIM SYSTEMS

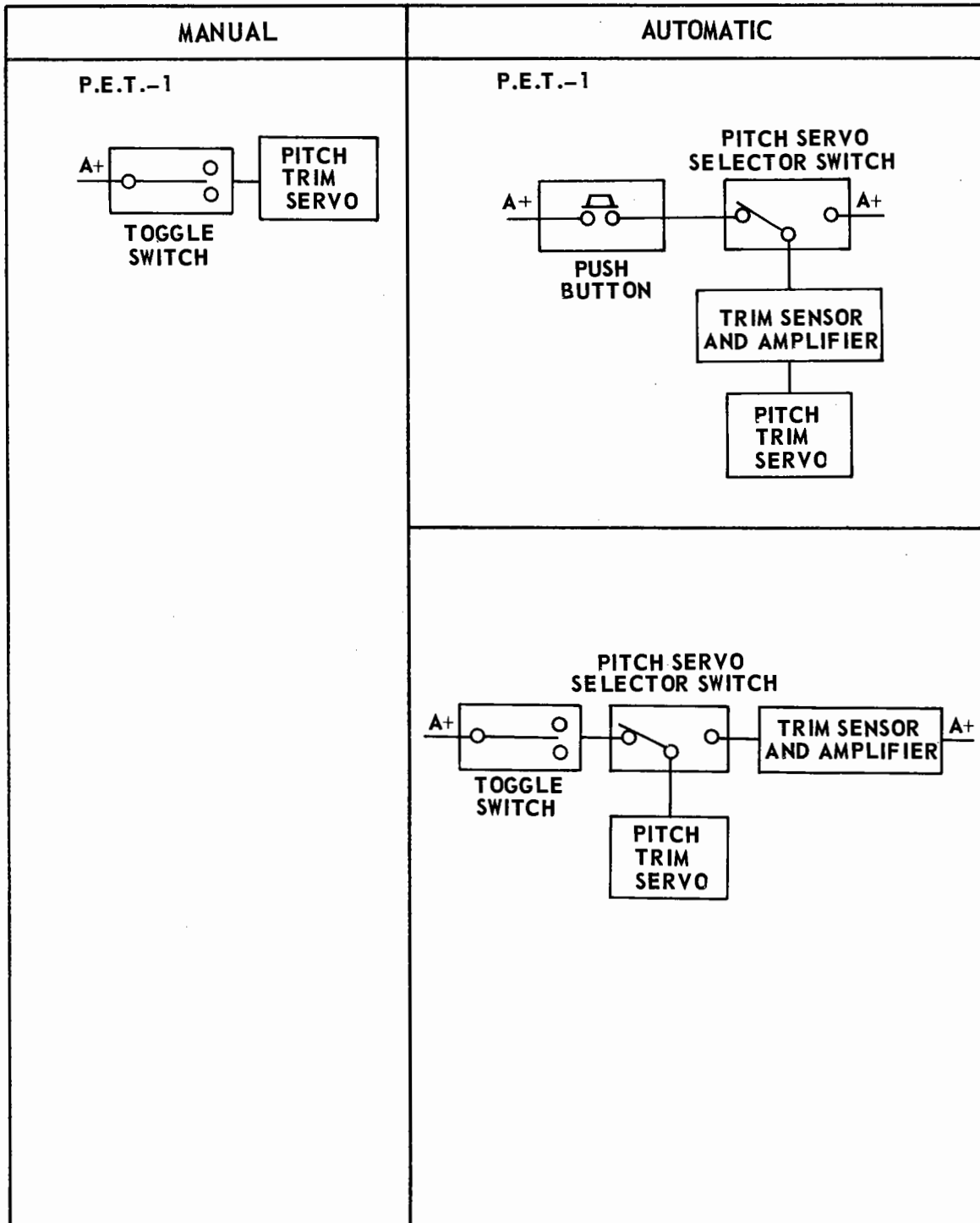

TABLE II-II. IDENTIFYING FEATURES
P. E. T. SERIES ELECTRIC PITCH TRIM SYSTEMS

MANUAL	AUTOMATIC
<p><u>P.E.T. - 1 VERO BEACH DESIGN</u> TOGGLE SWITCH ON CONTROL WHEEL NO RELAY IN TRIM SERVO NO TRIM SENSOR CENTER TAPPED MOTOR LARGE DISK ON CAPSTAN NOT USED WITH ALTIMATIC AUTOPILOT</p>	<p><u>P.E.T. - 1 VERO BEACH DESIGN</u> PUSH BUTTON SWITCH ON CONTROL WHEEL TRIM SENSOR AMPLIFIER ON TRIM SENSOR NO RELAY IN TRIM SERVO CENTER TAPPED MOTOR LARGE DISK ON CAPSTAN TRIM SENSOR AND AMPLIFIER USED 100% OF THE TIME WHETHER USED IN MANUAL MODE OR AUTOMATIC MODE</p>
	<p><u>P.E.T. - 2 VERO BEACH DESIGN</u> TOGGLE SWITCH ON CONTROL WHEEL TRIM SENSOR AMPLIFIER ON TRIM SENSOR RELAY IN TRIM SERVO CENTER TAPPED MOTOR LARGE DISK ON CAPSTAN TRIM SENSOR AND AMPLIFIER USED IN AUTOMATIC MODE ONLY</p>

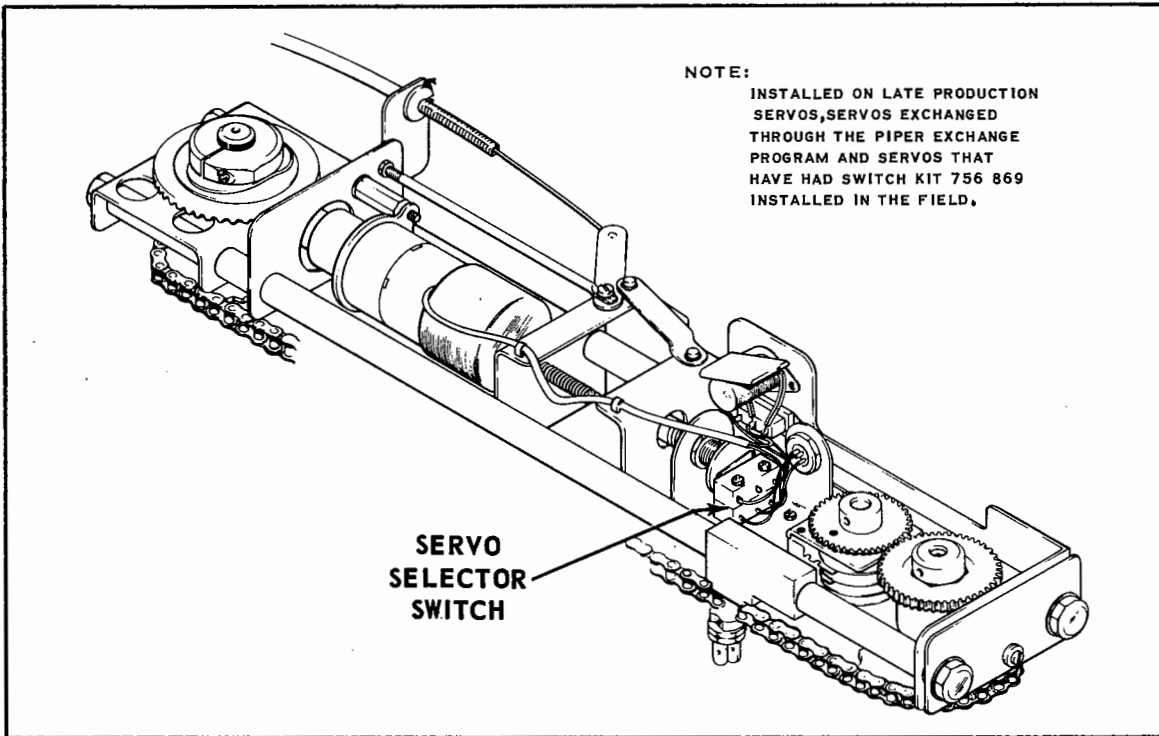

Figure 2-1. Servo Selector Switch Chain Type Pitch Servo

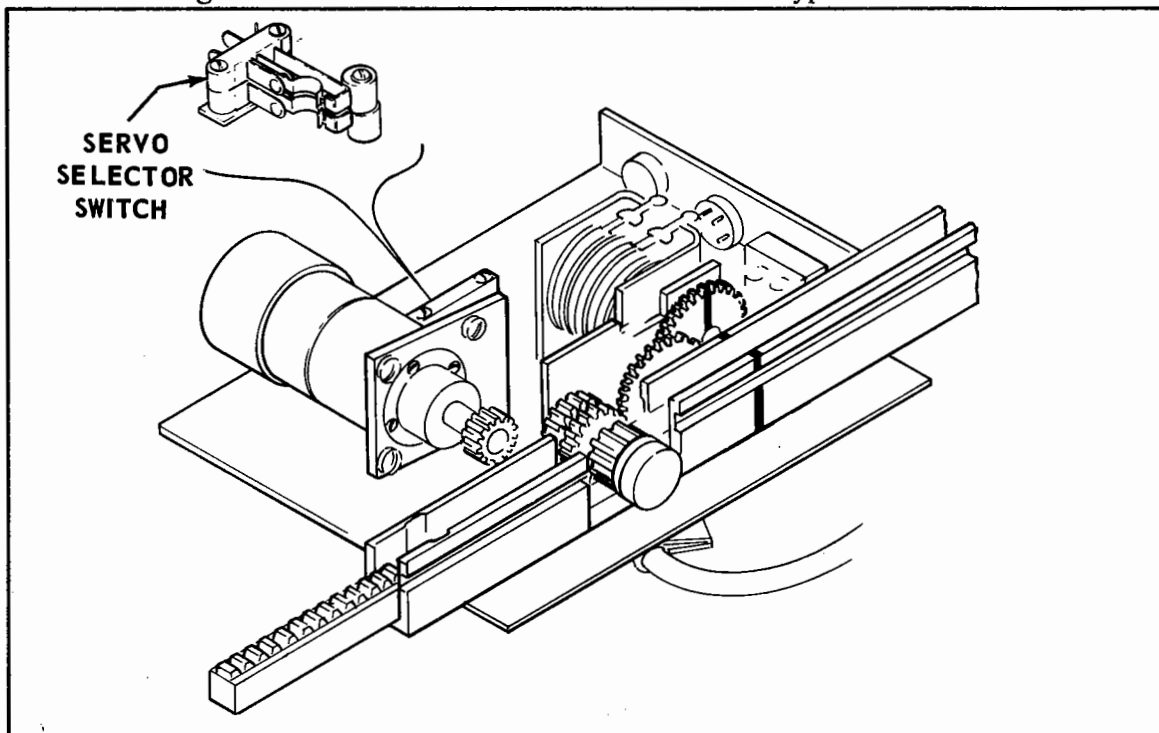

Figure 2-2. Servo Selector Switch Rack and Pinion Pitch Servo

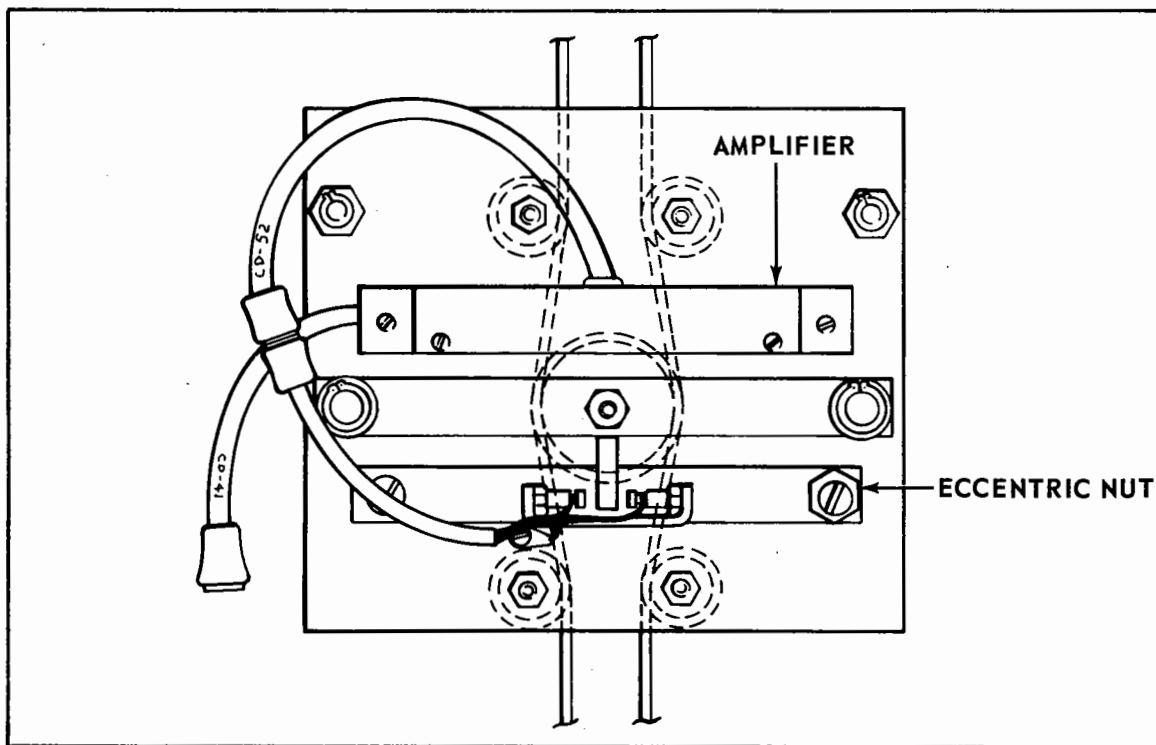

Figure 2-3. Plate Sensor Equal Elevator or Stabilator Cable Tension

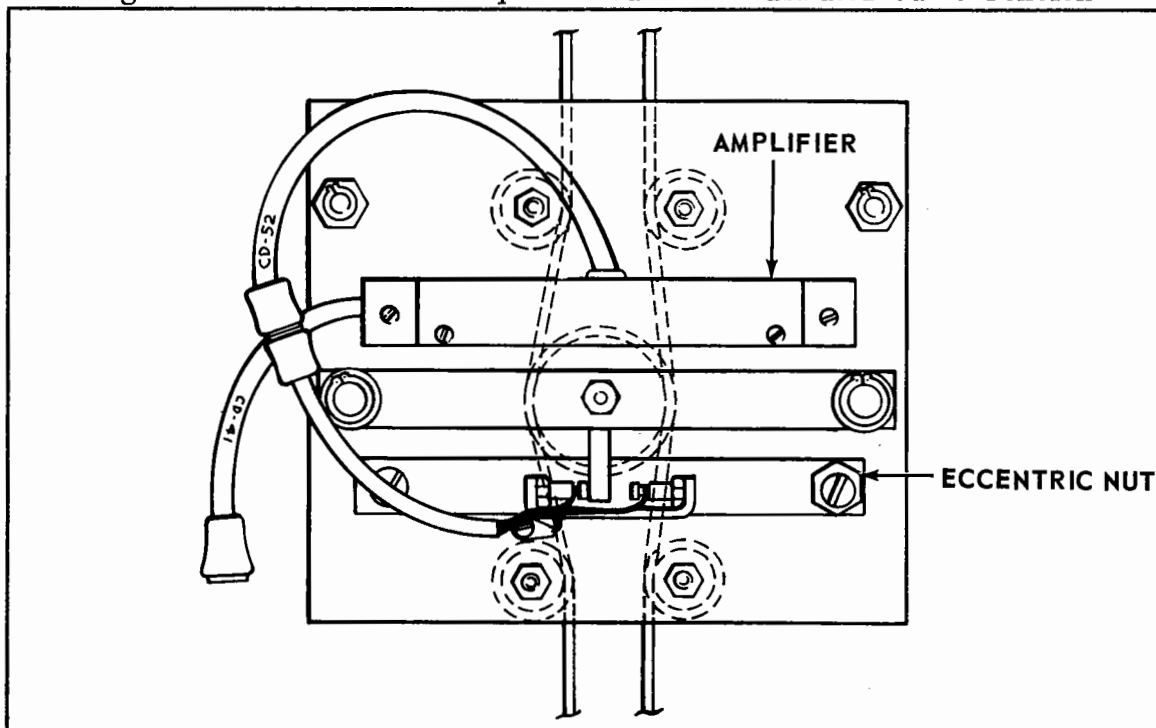

Figure 2-4. Plate Sensor Un-Equal Elevator or Stabilator Cable Tension

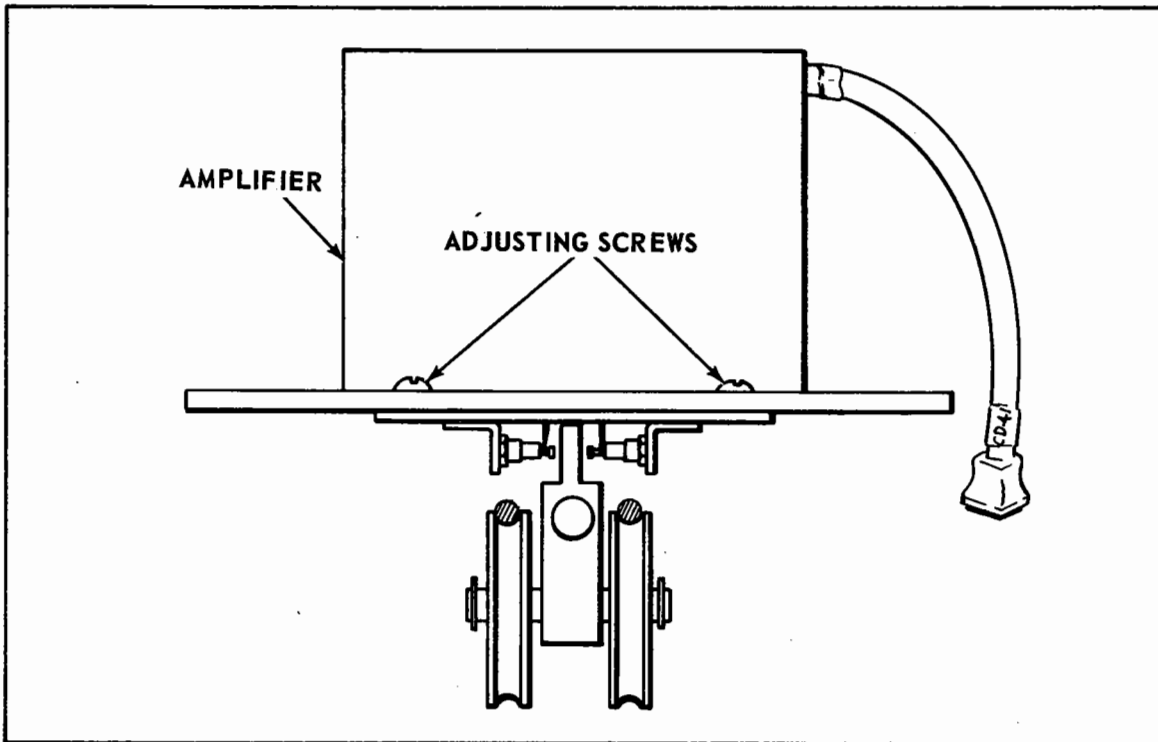

Figure 2-5. Pendulous Sensor Equal Elevator or Stabilator Cable Tension

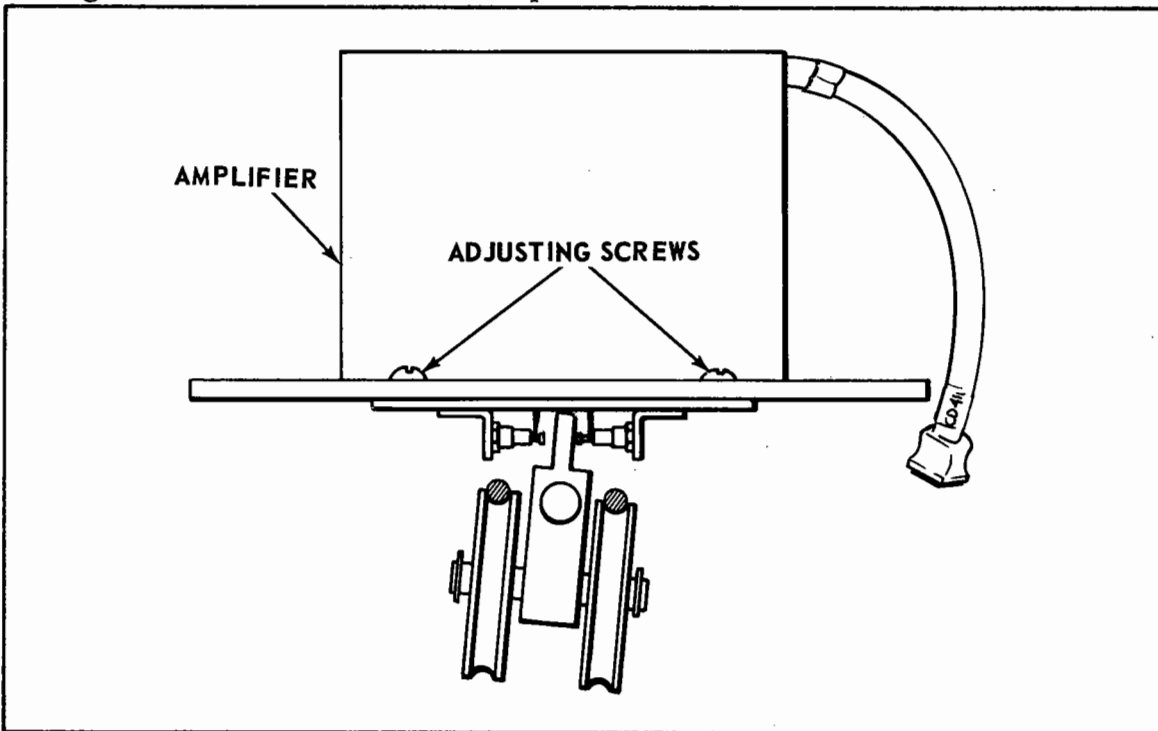

Figure 2-6. Pendulous Sensor Un-Equal Elevator or Stabilator Cable Tension

SECTION III

REMOVAL AND INSTALLATION

Paragraph		Page
3-1.	Introduction	3-3
3-2.	Removal of Trim Servo - PA-23-250	3-3
3-3.	Installation of Trim Servo - PA-23-250	3-4
3-4.	Removal of Pendulous Trim Sensor and Amplifier PA-23-250	3-4
3-5.	Installation of Pendulous Trim Sensor and Amplifier - PA-23-250	3-4
3-6.	Removal of Plate Type Trim Sensor and Amplifier PA-23-250	3-5
3-7.	Installation of Plate Type Trim Sensor and Amplifier - PA-23-250	3-6
3-8.	Removal of Trim Amplifier— Plate Type Trim Sensor - PA-23-250.	3-6
3-9.	Installation of Trim Amplifier— Plate Type Trim Sensor - PA-23-250.	3-6
3-10.	Removal of Trim Servo - PA-24 and PA-30	3-9
3-11.	Installation of Trim Servo - PA-24 and PA-30	3-9
3-12.	Removal of Pendulous Trim Sensor and Amplifier PA-24 and PA-30	3-10
3-13.	Installation of Pendulous Trim Sensor and Amplifier - PA-24 and PA-30	3-10
3-14.	Removal of Plate Type Trim Sensor and Amplifier PA-24 and PA-30	3-11
3-15.	Installation of Plate Type Trim Sensor and Amplifier - PA-24 and PA-30	3-12
3-16.	Removal of Trim Amplifier— Plate Type Trim Sensor - PA-24 and PA-30	3-12
3-17.	Installation of Trim Amplifier— Plate Type Trim Sensor - PA-24 and PA-30	3-13
3-18.	Removal of Trim Servo - PA-28	3-13
3-19.	Installation of Trim Servo - PA-28	3-14
3-20.	Removal of Trim Servo - PA-32	3-14
3-21.	Installation of Trim Servo - PA-32	3-15

PIPER PITCH TRIM SERVICE MANUAL

3-22.	Trim Sensor Centering Procedures and Trim Amplifier Delay Circuit Check in P. E. T. -1 and P. E. T. -2 Systems	3-15
3-23.	Removal of Electric Trim Stop Sensor Assembly PA-28-181, PA-32R-300, PA-32RT-300 and PA-32RT-300T	3-22
3-24.	Installation of Electric Trim Stop Sensor Assembly PA-28-181, PA-32R-300, PA-32RT-300 and PA-32RT-300T	3-22

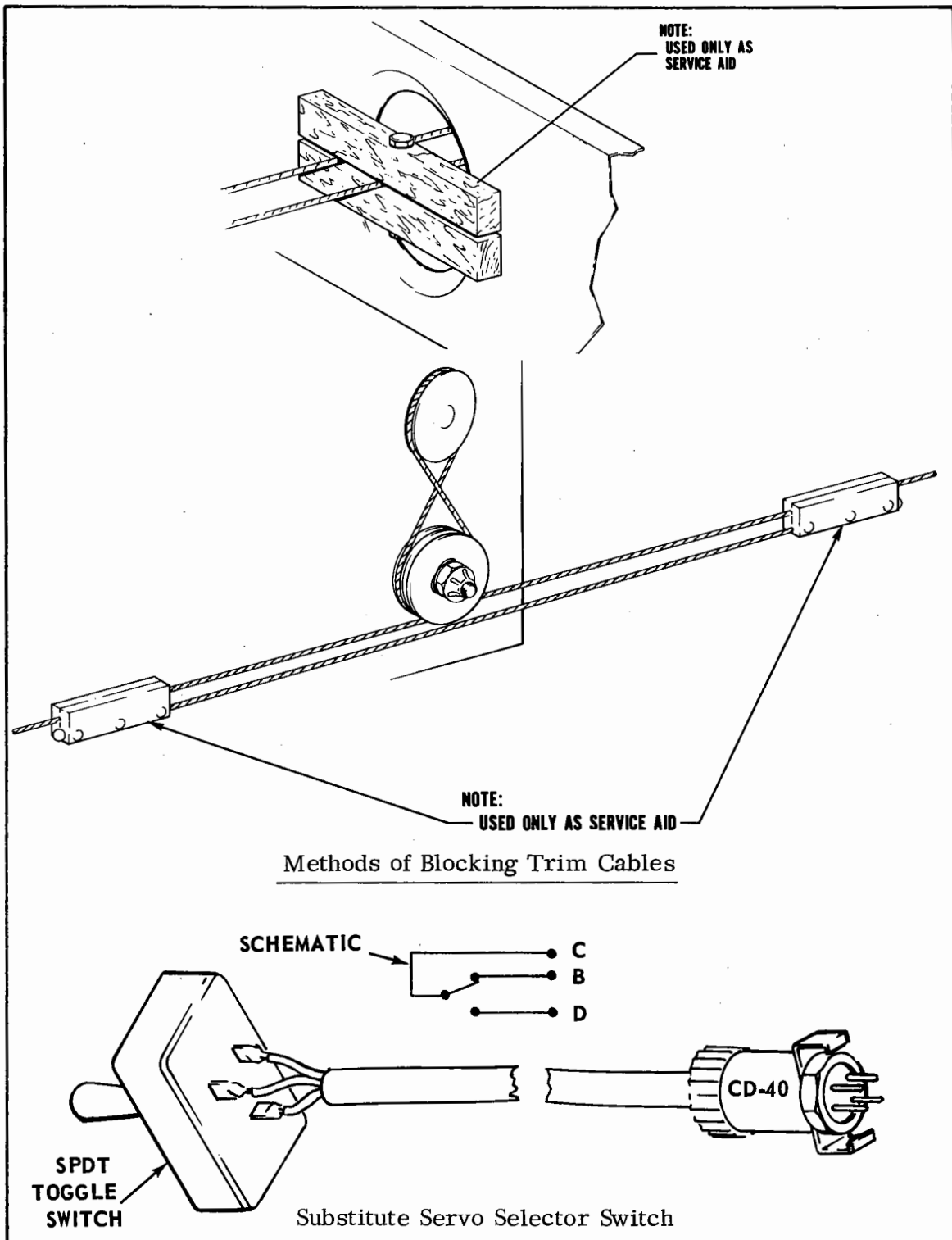

Figure 3-1. Servicing Aids

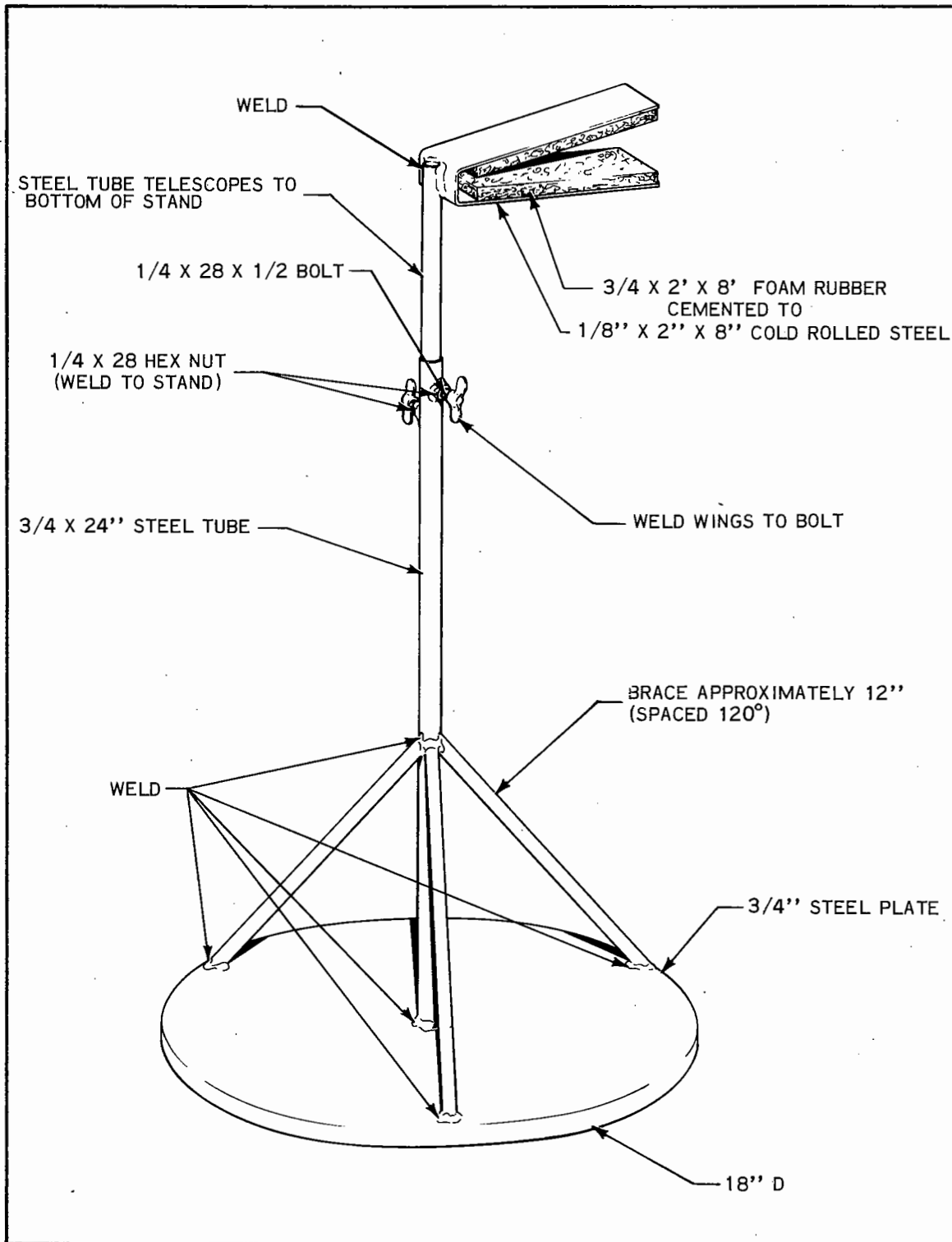

Figure 3-2. Typical Stabilator Holding Fixture

SECTION III

REMOVAL AND INSTALLATION

3-1. INTRODUCTION. The information in this section describes the procedures for removal and installation of the components of the P. E. T. Electric Pitch Trim Systems used in Piper airplanes. Included with the installation procedures are the necessary set-up and adjustment instructions. When any component of the trim system is installed, a complete functional check of the entire trim system must be made to confirm correct system operation. When using this section, refer to the type of component to be removed and installed. Refer to Paragraph 3-22 for Trim Sensor Centering Procedures and the Trim Amplifier Delay Circuit Check. To maintain cable routing of the trim cable during removal and installation of trim servos, it is recommended that the service aids shown in Figure 3-1 be utilized. Service aids as shown can be fabricated locally from shop material. The substitute Servo Selector Switch shown in Figure 3-1 can be fabricated from shop material. If in doubt about the operation of the Servo Selector Switch, the locally fabricated Servo Selector Switch may be substituted by connecting it to the trim cable CD-40 plug which is connected to the AutoPilot pitch servo.

3-2. REMOVAL OF TRIM SERVO. (PA-23-250.) The trim servo is located in the top aft baggage compartment.

- a. Access to the servo is through the aft baggage compartment door.
- b. Remove the box type trim panel forward of the baggage compartment dome light by removing six attaching screws.
- c. Remove the baggage area rear panel to gain access to the cable turnbuckles to release the tension on the cables.
- d. Disconnect all electrical connections from the servo assembly.
- e. Remove four mounting bolts securing the servo assembly to the mounting brackets.
- f. Unwrap trim cable from capstan and idler pulley and remove servo assembly from the airplane.

3-3. INSTALLATION OF TRIM SERVO. (PA-23-250.) (Refer to Figure 3-3.)

- a. Position trim servo on the mounting brackets and secure with mounting bolts.
- b. Route the trim cable from the forward part of the airplane around the top capstan groove, to the idler pulley and around the bottom capstan groove to the aft section of the airplane, completing a figure eight.
- c. Tighten the trim cable to obtain appropriate tension as listed in Table III-I.
- d. Connect all electrical connections to trim servo assembly and check servo operation.
- e. Install baggage area rear panel and secure with attaching screws.
- f. Install box type trim panel forward of baggage compartment dome light and secure with attaching screws.

3-4. REMOVAL OF PENDULOUS TRIM SENSOR AND AMPLIFIER. (PA-23-250.)

The trim sensor is located on a mounting bracket under the main spar of the airplane.

NOTE

If the trim amplifier on the pendulous trim sensor fails, a plate type trim sensor and trim amplifier will be provided as a replacement.

- a. Remove the bottom fuselage panel aft of the nose gear doors by removing screws securing panel.
- b. The cables on trim sensor can be removed by applying pressure to both cables and moving the cables out of trim sensor pulley grooves. If desired the stabilator control cable may be loosened to facilitate removing from the trim sensor.
- c. Disconnect the CD-41 electrical connection.
- d. Remove the screws securing the trim sensor to the mounting bracket.
- e. Remove the trim sensor from the airplane.

3-5. INSTALLATION OF PENDULOUS TRIM SENSOR AND AMPLIFIER. (PA-23-250.) (Refer to Figure 3-4.)

- a. With sensor pulleys facing down, position the trim sensor on the mounting bracket, align the trim sensor so the pulleys are parallel and centered over the stabilator control cables and install the appropriate mounting screws.
- b. Place the stabilator control cables in the top groove of the appropriate trim sensor pulleys.

- c. Check stabilator control cables for proper tension as listed in Table III-II.

NOTE

The stabilator control cables are routed over the trim sensor pulleys. The pulleys on the trim sensor must have horizontal movement from their normal position when the trim sensor is correctly aligned with the stabilator control cables.

- d. Refer to Paragraph 3-22 for trim sensor centering instructions.
- e. Connect the CD-41 electrical connection and perform the ground operational check of the pitch trim system as outlined in Section IV, Paragraph 4-6.
- f. Install bottom fuselage panel previously removed and secure with the appropriate screws.

3-6. REMOVAL OF PLATE TYPE TRIM SENSOR AND AMPLIFIER. (PA-23-250.) The trim sensor is located on a mounting bracket under the main spar of the airplane.

NOTE

If the trim amplifier on the plate type trim sensor fails, the amplifier can be replaced without removing the trim sensor or affecting the trim sensor centering adjustment.

- a. Remove the bottom fuselage panel aft of the nose gear doors by removing screws securing panel.
- b. The cables on trim sensor can be removed by applying pressure to both cables and moving the cables out of the trim sensor pulley grooves. If desired the stabilator control cable may be loosened to facilitate removing from the trim sensor.
- c. Disconnect the CD-41 electrical connection.
- d. Loosen nut under trim sensor plate at rear mounting screw and remove rear mounting screw, washer, and nut from the trim sensor.
- e. Remove the screws securing the trim sensor to mounting bracket.
- f. Remove the trim sensor from the airplane.

3-7. INSTALLATION OF PLATE TYPE TRIM SENSOR AND AMPLIFIER. (PA-23-250.) (Refer to Figure 3-5.)

- a. With the trim sensor pulleys facing down, route the stabilator control cables through the trim sensor pulleys. The trim sensor will center itself on the stabilator control cables.
- b. Position the trim sensor on the forward mounting bracket and secure with appropriate screws.
- c. Install screw, washer and nut in rear mounting hole.
- d. Adjust mounting screw and nut as required to align the trim sensor parallel with the stabilator control cables.
- e. Check stabilator control cables for proper tension as listed in Table III-II.

NOTE

The outboard pulleys on the trim sensor must have freedom of rotation and vertical movement from their normal position when the trim sensor is properly aligned with the stabilator control cables.

- f. Refer to Paragraph 3-22 for trim sensor centering instructions.
- g. Connect the CD-41 electrical connection and perform the ground operational check of the pitch trim system as outlined in Section IV, Paragraph 4-6.
- h. Install bottom fuselage panel previously removed and secure with the appropriate screws.

3-8. REMOVAL OF TRIM AMPLIFIER—PLATE TYPE TRIM SENSOR. (PA-23-250.) The trim amplifier is located on the trim sensor mounting plate under the main spar of the airplane.

- a. Remove the bottom fuselage panel aft of the nose gear doors by removing screws securing panel.
- b. Disconnect the CD-41 and CD-52 electrical connections.
- c. Disconnect the end of the braided lead going from the trim sensor linkage bar to a terminal on the side of the amplifier by removing the retaining nut on the amplifier terminal.
- d. Remove the mounting screws from either end of the amplifier and remove the amplifier from the trim sensor mounting plate.

3-9. INSTALLATION OF TRIM AMPLIFIER—PLATE TYPE TRIM SENSOR. (PA-23-250.) (Refer to Figure 3-5.)

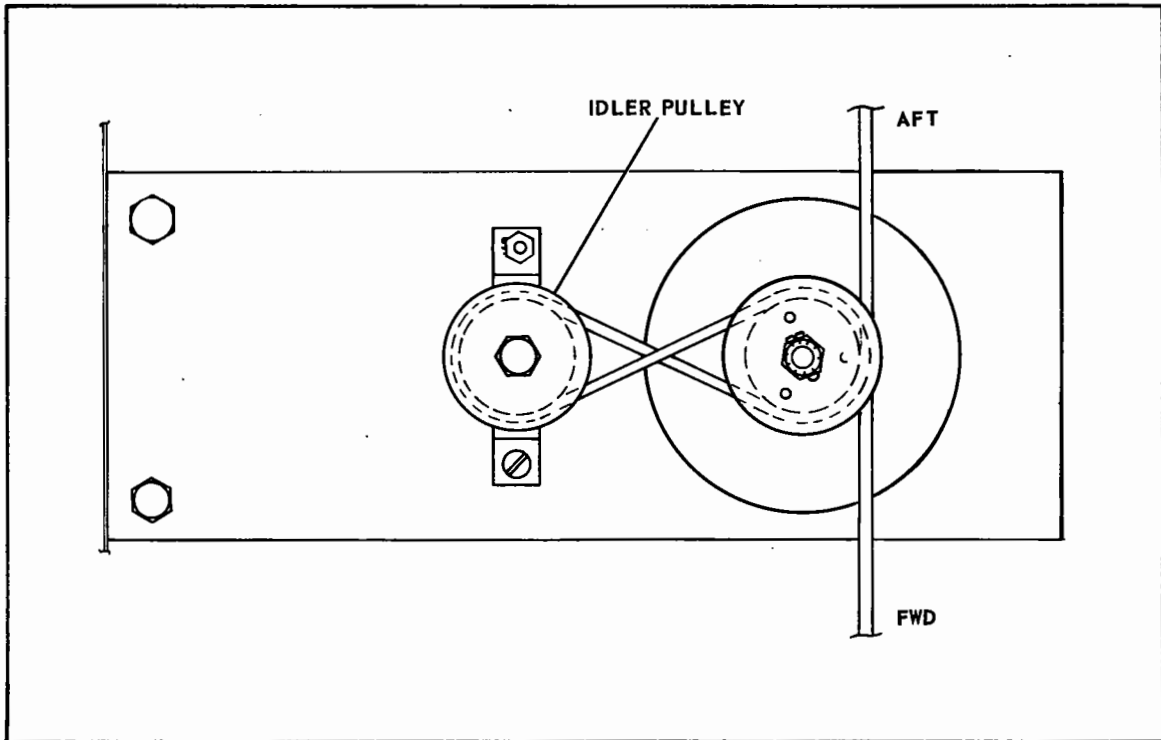

Figure 3-3. PA-23-250, PA-24 and PA-30 Trim Servo Cable Routing

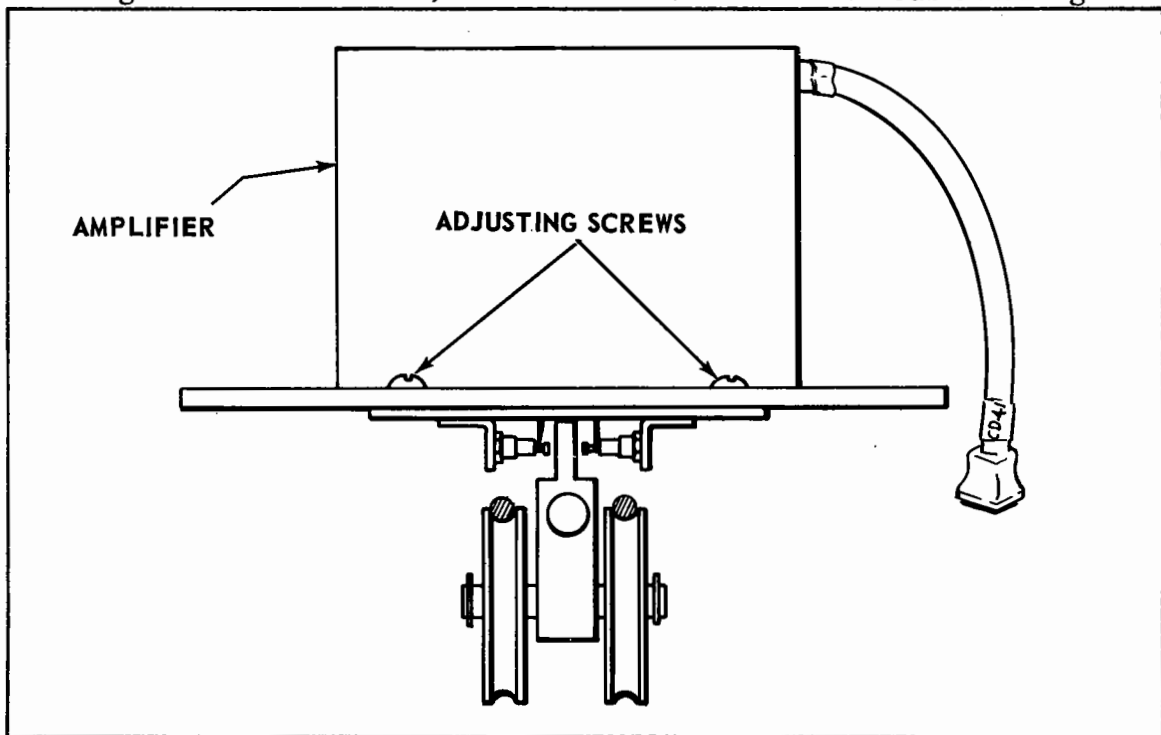

Figure 3-4. PA-23-250, PA-24 and PA-30 Pendulous Trim Sensor

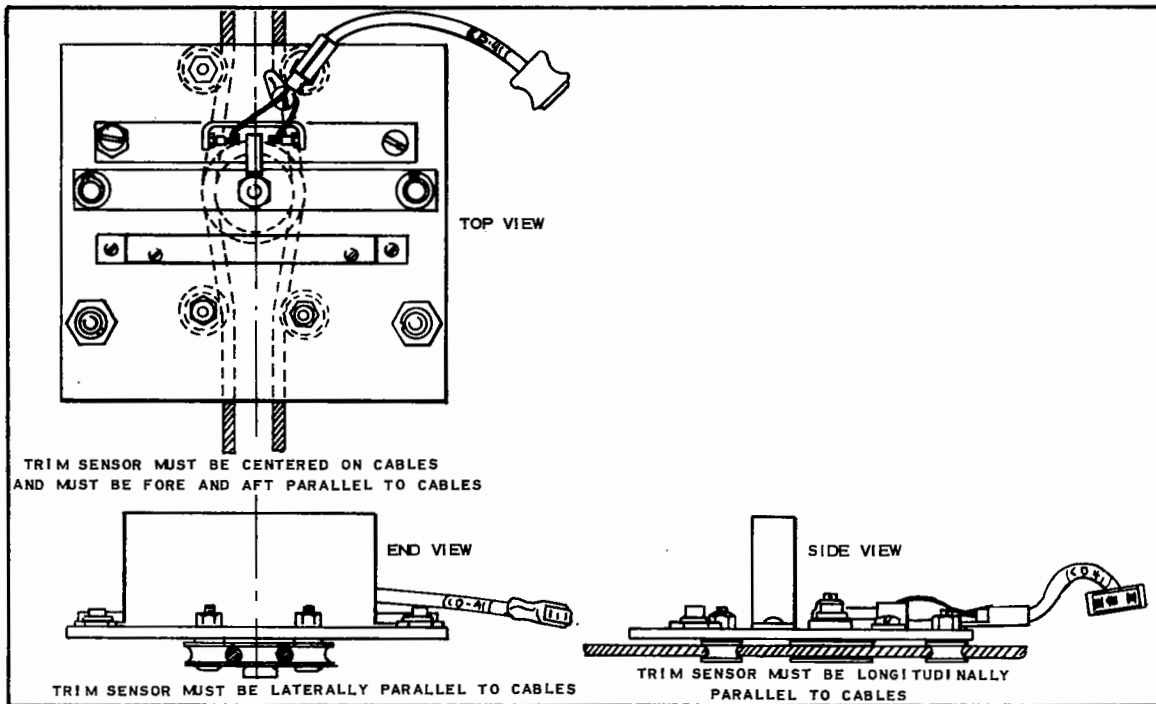

Figure 3-5. PA-23-250, PA-24 and PA-30 Positioning and Alignment of Plate Type Trim Sensor

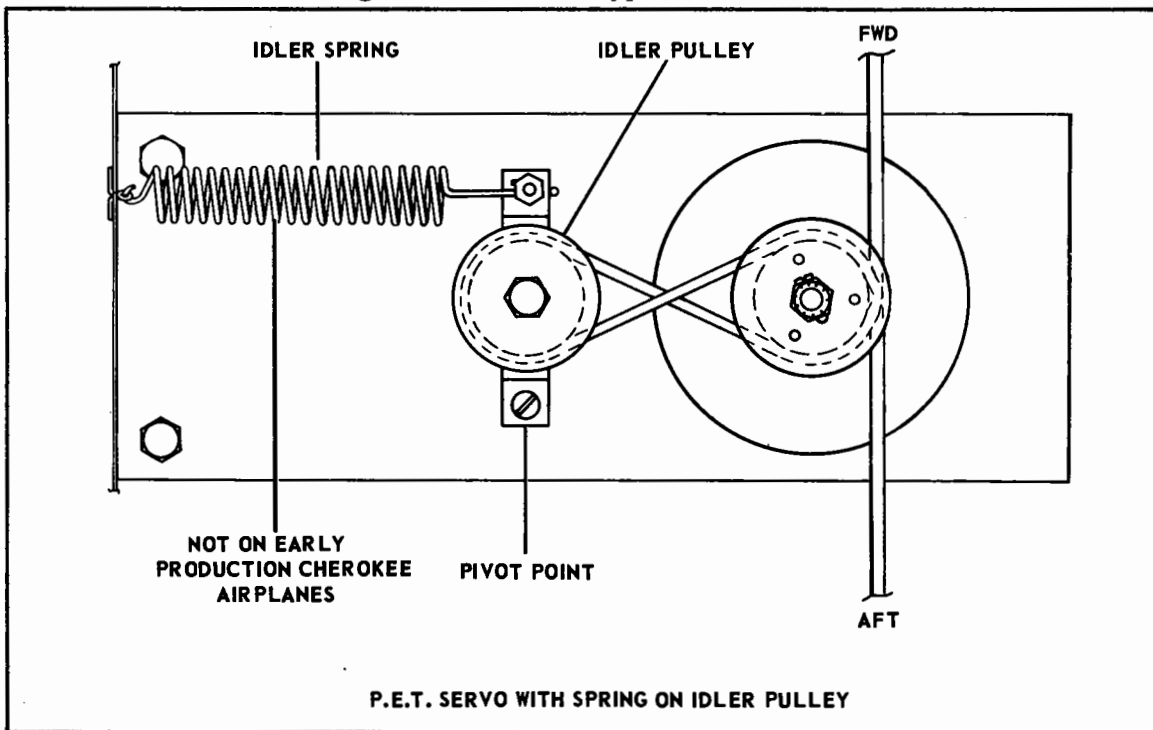

Figure 3-6. PA-28 Trim Servo Cable Routing

- a. Position the trim amplifier on the trim sensor mounting plate and secure with appropriate screws.
- b. Connect the braided lead to the amplifier terminal and secure with retaining nut.
- c. Connect the CD-41 and CD-52 electrical connections and perform the ground operational check of the pitch trim system as outlined in Section IV, Paragraph 4-6.
- d. Install bottom fuselage panel previously removed and secure with appropriate screws.

3-10. REMOVAL OF TRIM SERVO. (PA-24 and PA-30.) The trim servo is located aft of the baggage compartment on the upper fuselage.

NOTE

When servicing six-place airplanes, the 5th and 6th seats must be removed before proceeding with the following instructions.

- a. Access to the servo is through the baggage compartment door.
- b. Remove attaching screws from left rear window trimstrip and remove trimstrip.
- c. Remove attaching screws from the hat shelf panel and remove panel by pushing right side of panel aft to force left side of panel forward to free panel from right rear window trimstrip.
- d. Remove attaching screws from rear baggage area panels and remove panels to gain access to turnbuckle to release cable tension.
- e. Disconnect electrical connections.
- f. Remove four mounting bolts from trim servo assembly mounting bracket.
- g. Unwrap trim cable from the capstan and idler pulley and remove servo assembly from the airplane.

3-11. INSTALLATION OF TRIM SERVO. (PA-24 and PA-30.) (Refer to Figure 3-3.)

- a. Position trim servo on mounting bracket and secure with mounting bolts.
- b. Route the trim cable from the forward part of the airplane around the top capstan groove, to the idler pulley and around the bottom capstan groove to the aft section of the airplane, completing a figure eight.
- c. Tighten the trim cable to obtain appropriate tension as listed in Table III-I.

- d. Connect all electrical connections to trim servo assembly and check servo operation.
- e. Install rear baggage area panels and secure with attaching screws.
- f. Install hat shelf panel and left rear window trimstrip and secure with attaching screws.

3-12. REMOVAL OF PENDULOUS TRIM SENSOR AND AMPLIFIER. (PA-24 and PA-30.)

NOTE

When servicing standard airplanes, the sensor is beneath the forward access footwell panel of the left rear seat. On the six-place airplanes the sensor is beneath the forward access footwell panel of the center left seat. In either case, appropriate seat must be removed to gain access to sensor.

NOTE

If the trim amplifier on the pendulous trim sensor fails, a plate type trim sensor and trim amplifier will be provided as a replacement.

- a. Remove carpet from footwell.
- b. Remove forward access panel of footwell by removing attaching screws.
- c. The cables on trim sensor can be removed by applying pressure to both cables and moving the cables out of trim sensor pulley grooves. If desired the stabilator control cable may be loosened to facilitate removing from the trim sensor.
- d. Disconnect the CD-41 electrical connection.
- e. Remove the screws securing the trim sensor to the mounting bracket.
- f. Remove the trim sensor from the airplane.

3-13. INSTALLATION OF PENDULOUS TRIM SENSOR AND AMPLIFIER. (PA-24 and PA-30.) (Refer to Figure 3-4.)

- a. With sensor pulleys facing down, position the trim sensor on the mounting bracket. Align the trim sensor so the pulleys are parallel and centered over the stabilator control cables and install the appropriate mounting screws.

- b. Place the stabilator control cables in the top groove of the appropriate trim sensor pulleys.
- c. Check stabilator control cables for proper tension as listed in Table III-II.

NOTE

The stabilator control cables are routed over the trim sensor pulleys. The pulleys on the trim sensor must have horizontal movement from their normal position when the trim sensor is correctly aligned with the stabilator control cables.

- d. Refer to Paragraph 3-22 for trim sensor centering instructions.
- e. Connect the CD-41 electrical connection and perform the ground operational check of the pitch trim system as outlined in Section IV, Paragraph 4-6.
- f. Install forward footwell access panel and secure with attaching screws.
- g. Install footwell carpet and appropriate seat previously removed.

3-14. REMOVAL OF PLATE TYPE TRIM SENSOR AND AMPLIFIER. (PA-24 and PA-30.)

NOTE

When servicing standard airplanes, the sensor is beneath the forward access footwell panel of the left rear seat. On the six-place airplanes the sensor is beneath the forward access footwell panel of the center left seat. In either case, appropriate seat must be removed to gain access to sensor.

NOTE

If the trim amplifier on the plate type trim sensor fails, the amplifier can be replaced without removing the trim sensor or affecting the trim sensor centering adjustment.

- a. Remove carpet from footwell.
- b. Remove forward access panel of footwell by removing attaching screws.
- c. The cables on trim sensor can be removed by applying pressure to both cables and moving the cables out of the trim sensor pulley grooves. If desired

the stabilator control cable may be loosened to facilitate removing from the trim sensor.

- d. Disconnect the CD-41 electrical connection.
- e. Loosen nut under trim sensor plate at rear mounting screw and remove rear mounting screw, washer and nut from the trim sensor.
- f. Remove the screws securing the trim sensor to mounting bracket.
- g. Remove the trim sensor from the airplane.

3-15. INSTALLATION OF PLATE TYPE TRIM SENSOR AND AMPLIFIER. (PA-24 and PA-30.) (Refer to Figure 3-5.)

- a. With the trim sensor pulleys facing down, route the stabilator control cables through the trim sensor pulleys. The trim sensor will center itself on the stabilator control cables.
- b. Position the trim sensor on the forward mounting bracket and secure with appropriate screws.
- c. Install screw, washer and nut in rear mounting hole.
- d. Adjust mounting screw and nut as required to align the trim sensor parallel with the stabilator control cables.
- e. Check stabilator control cables for proper tension as listed in Table III-II.

NOTE

The outboard pulleys on the trim sensor must have freedom of rotation and vertical movement from their normal position when the trim sensor is properly aligned with the stabilator control cables.

- f. Refer to Paragraph 3-22 for trim sensor centering instructions.
- g. Connect the CD-41 electrical connection and perform the ground operational check of the pitch trim system as outlined in Section IV, Paragraph 4-6.
- h. Install forward footwell access panel and secure with attaching screws.
- i. Install footwell carpet and appropriate seat previously removed.

3-16. REMOVAL OF TRIM AMPLIFIER—PLATE TYPE TRIM SENSOR. (PA-24 and PA-30.)

The trim amplifier is located on the trim sensor mounting plate.

NOTE

When servicing standard airplanes, the sensor is beneath the forward access footwell panel of the left rear seat. On the six-place airplanes the sensor is beneath the forward access footwell panel of the center left seat. In either case, appropriate seat must be removed to gain access to the sensor.

- a. Remove carpet from footwell.
- b. Remove forward access panel of footwell by removing attaching screws.
- c. Disconnect the CD-41 and CD-52 electrical connections.
- d. Disconnect the end of the braided lead going from the trim sensor linkage bar to a terminal on the side of the amplifier by removing the retaining nut on the amplifier terminal.
- e. Remove the mounting screws from either end of the amplifier and remove the amplifier from the trim sensor mounting plate.

3-17. INSTALLATION OF TRIM AMPLIFIER— PLATE TYPE TRIM SENSOR. (PA-24 and PA-30.) (Refer to Figure 3-5.)

- a. Position the trim amplifier on the trim sensor mounting plate and secure with appropriate screws.
- b. Connect the braided lead to the amplifier terminal and secure with retaining nut.
- c. Connect the CD-41 and CD-52 electrical connections and perform the ground operational check of the pitch trim system as outlined in Section IV, Paragraph 4-6.
- d. Install forward footwell access panel and secure with attaching screws.
- e. Install footwell carpet and appropriate seat previously removed.

3-18. REMOVAL OF TRIM SERVO. (PA-28.) The trim servo is located aft of the baggage compartment.

NOTE

On PA-28 airplanes the servo is mounted on brackets on either the upper or lower fuselage. Access to the trim servo is through the baggage compartment.

- a. Remove securing screws in rear baggage compartment panel and remove panel.
- b. Disconnect electrical connections from the servo.
- c. Remove four mounting bolts securing the servo assembly to the mounting brackets.
- d. Unwrap trim cable from capstan and idler pulleys and remove assembly from the airplane.

3-19. INSTALLATION OF TRIM SERVO. (PA-28.) (Refer to Figure 3-6 or 3-7.)

- a. Position trim servo on mounting brackets and secure with mounting bolts.
- b. If an idler spring is installed on the servo, temporarily disconnect the spring from cotter pin at end of servo.
- c. On PA-28-150, PA-28-160 and PA-28-180 airplanes with Serial Nos. 28-2172 to 28-4377 inclusive; PA-28-235 airplanes with Serial Nos. 28-10606 to 28-10719 inclusive; and PA-28-140 airplanes with Serial Nos. 28-20002 and up, (refer to Figure 3-6), route the trim cable from the forward section of the airplane around the top capstan groove, around the aft side of the idler pulley located in the center of the servo, around the bottom capstan groove toward the aft section of the airplane until cable forms a figure eight. Proceed to step "e".
- d. On PA-28-151, Serial Nos. 28-7415001 and up; PA-28-161, Serial Nos. 28-7716001 and up; PA-28-180, Serial Nos. 28-4378 and up; PA-28-181, Serial Nos. 28-7690001 and up; PA-28R-180, Serial Nos. 28R-30005 and up; PA-28R-200, Serial Nos. 28R-35001 and up; PA-28R-201, Serial Nos. 28R-7737001 and up; PA-28R-201T, Serial Nos. 28R-7703001 and up; PA-28-235, Serial Nos. 28-10720 and up, (refer to Figure 3-7), route the trim cable from the forward section of the airplane around the aft idler pulley; then around the top capstan groove and around the aft side of the idler pulley located approximately in the center of the servo. Form a figure eight by continuing the cable around the bottom capstan groove; then around the forward idler pulley and route trim cable toward the aft section of airplane.
- e. Tighten the trim cable to obtain appropriate tension as listed in Table III-I.
- f. Reconnect idler spring to cotter pin at end of servo.
- g. Connect electrical connections to trim servo assembly and check servo operation.
- h. Install rear baggage compartment panel and secure with attaching screws.

3-20. REMOVAL OF TRIM SERVO. (PA-32.) The trim servo is located aft of the baggage compartment. Access to the servo is through the aft baggage compartment.

- a. Remove securing screws in rear baggage compartment panel and remove panel.

- b. Disconnect electrical connections from the servo.
- c. Remove four mounting bolts securing the servo assembly to the mounting brackets.
- d. Unwrap trim cable from capstan and idler pulleys and remove assembly from the airplane.

3-21. INSTALLATION OF TRIM SERVO. (PA-32.) (Refer to Figure 3-7.)

- a. Position trim servo on mounting brackets and secure with mounting bolts.
- b. If an idler spring is installed on the servo, temporarily disconnect the spring from the cotter pin at end of servo.
- c. Route the trim cable from the forward section of the airplane around the aft idler pulley, then around the top capstan groove and around the aft side of the idler pulley located approximately in the center of the servo. Form a figure eight by continuing the cable around the bottom capstan groove, then around the forward idler pulley and route trim cable toward the aft section of the airplane.
- d. Tighten the trim cable to obtain appropriate tension as listed in Table III-I.
- e. Reconnect idler spring to cotter pin at end of servo.
- f. Connect electrical connections to trim servo assembly and check servo operation.
- g. Install rear baggage compartment panel and secure with attaching screws.

3-22. TRIM SENSOR CENTERING PROCEDURES AND TRIM AMPLIFIER DELAY CIRCUIT CHECK IN P.E.T. -1 AND P.E.T. -2 SYSTEMS. The two types of trim sensors used in Piper airplanes with the P.E.T. -1 and P.E.T. -2 Automatic Pitch Trim Systems are shown in illustration form in this section of the manual, (Refer to Figure 3-8 and 3-9). When making trim sensor centering adjustments, it is very important to ascertain the type of sensor being adjusted and to follow the detailed instructions for that particular type sensor to avoid damage to the test equipment and the sensor. The procedure used to check for proper functioning of the trim amplifier delay circuit is incorporated in the trim sensor centering procedure instructions. This is done so both tests can be accomplished with the initial hook up of test equipment.

- a. The following listed test equipment should be used to adjust trim sensor centering.
 - 1. Output Meter (66B83-1).
 - 2. Output Meter Cable (30A177).
- b. Support the stabilator in approximate level flight position before proceeding with trim sensor contact centering procedure, regardless of type of sensor being serviced.

NOTE

The stabilator should be firmly supported at its trailing edge. Place support on stabilator, not on trim tab. Do not attempt to hold the stabilator in position as it is impossible to hand hold the stabilator steady enough to accomplish the correct adjustment. A typical stabilator holding fixture is shown in Figure 3-2. Such a fixture should be used in conjunction with a jack placed under the tail skid.

c. Centering procedure for plate type trim sensor with amplifier. (Refer to Figure 3-8.)

1. Turn OFF airplane master switch.
2. Connect either end of Cable 30A177 to the Output Meter. (The 30A177 Cable is the one with a single wire lead terminating with an alligator clip.)
3. Connect the other end of the Cable to the CD-41 plug coming from the top of the amplifier.

CAUTION

When testing a trim sensor on the bench, the sensor must be grounded to prevent damage to the transistors. In the airplane, it is grounded through the installation of the sensor to the airframe.

4. Connect alligator clip of Cable 30A177 to 12-volt POSITIVE source.
5. Make sure the sensor pulleys are parallel to the stabilator cables and stabilator is blocked to approximately level flight.
6. Turn on 12-volt source.
7. For Centering Check if Output Meter indicates zero output, the contacts are centered, proceed to Step D. If not, proceed with the following steps.
 - (a) Loosen both screws of the contact support bar. (Refer to Figure 3-8.)
 - (b) Rotate eccentric nut on the contact support bar to obtain zero output on the meter.
 - (c) Tighten screws on the contact support bar.

- (d) For Trim Amplifier Delay Circuit Check, apply forward pressure on the control column and observe the Output Meter needle movement. The needle should show immediate movement during the initial part of its travel, and then the rate of needle movement should taper off until the needle comes to rest in the area of the green dot. (Approximately .25 on the scale.) When forward pressure on the control column is released, the needle should either return to zero or remain deflected in the same direction but should not reverse direction.
- (e) Apply aft pressure on the control column and observe the Output Meter needle movement in the opposite direction. The needle should show immediate movement during the initial part of its travel, and then the rate of needle movement should taper off until the needle comes to rest in the area of the green dot. (Approximately .25 on the scale.) When aft pressure on the control column is released, the needle should either return to zero or remain deflected in the same direction but should not reverse direction.

NOTE

If the Output Meter reverses direction of deflection when the forward or aft pressure on the control wheel is released; the trim sensor centering must be re-accomplished.

- (f) Turn off 12-volt source and disconnect Output Meter and associated cables.
 - (g) Connect CD-41 electrical connection.
- d. Centering procedure for pendulous type trim sensor with amplifier. (Refer to Figure 3-9.)
1. Turn OFF airplane master switch.
 2. Connect either end of Cable 30A177 to the Output Meter. (The 30A177 Cable is the one with a single wire lead terminating with an alligator clip.)
 3. Connect the other end of the Cable to the CD-41 plug coming from the top of the amplifier.

CAUTION

When testing a trim sensor on the bench, the sensor must be grounded to prevent damage to the transistors. In the airplane, it is grounded through the installation of the sensor to the airframe.

4. Connect alligator clip Cable 30A177 to 12-volt POSITIVE source.
5. Stabilator to be blocked to approximately level flight.
6. Turn on 12-volt source.
7. For Centering Check if Output Meter indicates zero output, the contacts are centered, proceed to Step F. If not, proceed with the following steps.
 - (a) Remove amplifier cover. It is not necessary to completely remove screws securing cover, as cover is slotted.
 - (b) Carefully loosen the two adjusting screws to permit the contact adjustment bracket to move with some friction. (Refer to Figure 3-9.)
 - (c) Grasp both stabilator cables, pull evenly upward, then release cables and allow them to snap back to position.

NOTE

When the cables snap back to position, the cables vibrate the pendulum assembly which centers the adjustable contacts.

- (d) When the Output Meter is centered, carefully tighten the adjusting screws. Tighten each adjusting screw a slight amount then proceed to the other screw. Repeat this sequence until both screws are tight.
- (e) The Output Meter should read zero output. If zero output is not obtained, repeat steps b through d.
- (f) For Trim Amplifier Delay Circuit Check, apply forward pressure on the control column and observe the Output Meter needle movement. The needle should show immediate movement during the initial part of its travel, and then the rate of needle movement should taper off until the needle comes to rest in area of the green dot. (Approximately .25 on the scale.) When forward pressure on the control column is released, the needle should either return to zero or remain deflected in the same direction but should not reverse direction.
- (g) Apply aft pressure on the control column and observe the Output Meter needle movement in the opposite direction. The needle should show immediate movement during the initial part of its travel, and then the rate of needle movement should taper off until the needle comes to rest in the area of the green dot. (Approximately .25 on the scale.) When aft pressure on the control column is released, the needle should either return to zero or remain deflected in the same direction but should not reverse direction.

NOTE

If the Output Meter reverses direction of deflection when the forward or aft pressure on the control wheel is released, the trim sensor centering must be reaccomplished.

- (h) Turn off 12-volt source and disconnect Output Meter and associated cables.
- (i) Connect CD-41 electrical connector.
- (j) Install amplifier cover and secure.

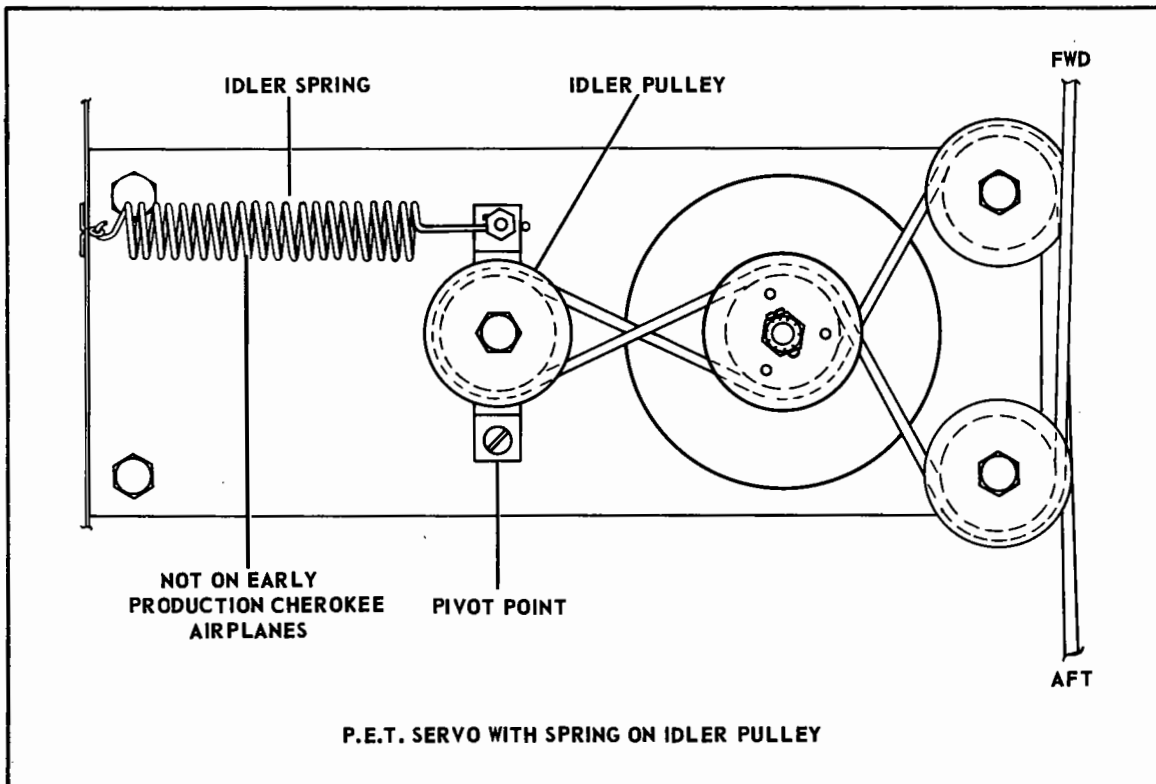

Figure 3-7. PA-28 and PA-32 Trim Servo Cable Routing

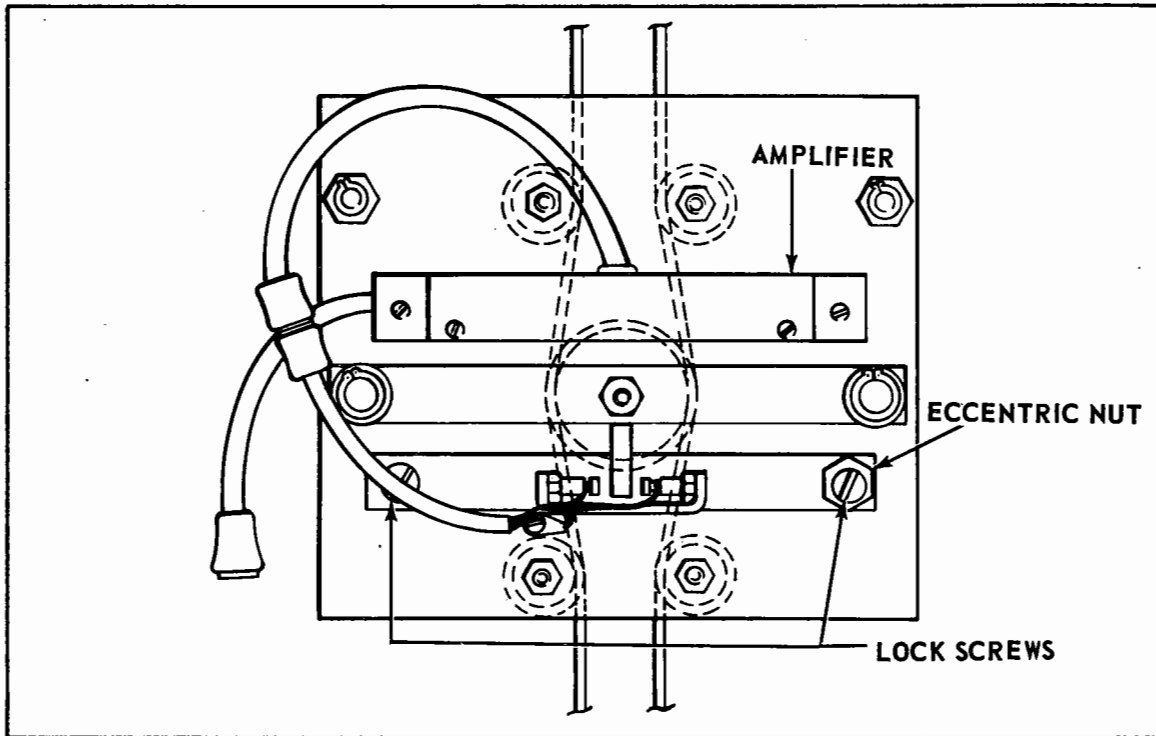

Figure 3-8. Plate Sensor with Amplifier

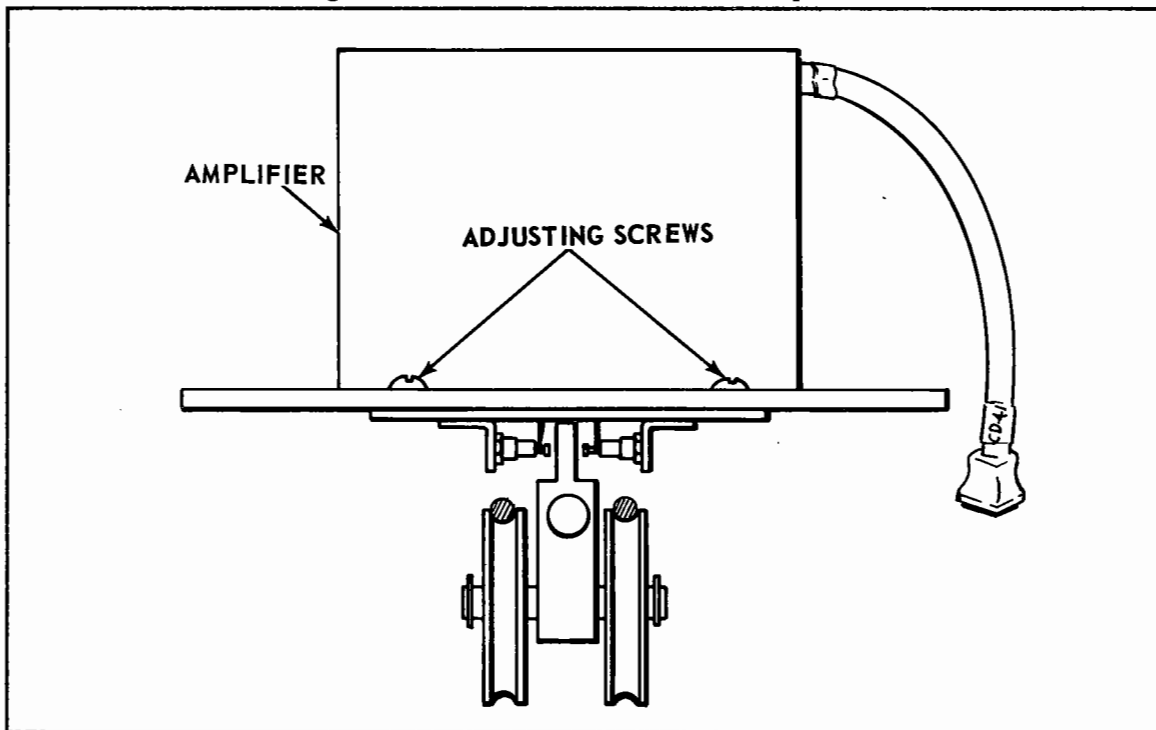

Figure 3-9. Pendulous Sensor with Amplifier

TABLE III-I. TRIM SERVO CABLE TENSION

AIRPLANE	CABLE	CABLE TENSION
PA-23-250	Stabilator Trim	10 lbs. \pm 20% (2 lbs.)
PA-24	Stabilator Trim	12 lbs. \pm 20% (2.4 lbs.)
PA-28	Stabilator Trim	10 lbs. \pm 1 lb.
PA-30	Stabilator Trim	12 lbs. \pm 20% (2.4 lbs.)
PA-32	Stabilator Trim	10 lbs. \pm 1 lb.

TABLE III-II. TRIM SENSOR CABLE TENSION

AIRPLANE	CABLE	CABLE TENSION
PA-23-250	Stabilator	35 lbs. \pm 10% (3.5 lbs.)
PA-24	Stabilator	18 lbs. \pm 20% (3.6 lbs.)
PA-30	Stabilator	18 lbs. \pm 20% (3.6 lbs.)

3-23. REMOVAL OF ELECTRIC TRIM STOP SENSOR ASSEMBLY. (PA-28-181, PA-32R-300, PA-32RT -300 and PA-32RT-300T only.) The electric trim stop sensor assembly is located behind the left instrument panel.

- a. Access to the unit is from beneath the left instrument panel.
- b. Disconnect the electrical connections from the electric trim stop sensor assembly. Identify wires to facilitate reinstallation.
- c. Disconnect the static lines from the airspeed indicator and the static line T fitting. Identify hoses to facilitate reinstallation. To prevent contamination, place protective covers over the ends of the hoses, the airspeed indicator and the static line T fitting ports.
- d. Remove the screws securing the electric trim stop sensor assembly to the instrument panel and remove sensor assembly from the airplane.

3-24. INSTALLATION OF ELECTRIC TRIM STOP SENSOR ASSEMBLY. (PA-28-181, PA-32R-300, PA-32RT-300 and PA-32RT-300T.) (Refer to Figure 3-10.)

- a. Position the electric trim stop sensor assembly in its proper mounting location behind the left instrument panel and secure with appropriate screws.
- b. Remove any caps which were placed over the hoses, the airspeed indicator and the static line T fitting ports.
- c. Connect hoses to the proper ports of the airspeed indicator and the static line T fitting.
- d. Connect the electrical connections to the electric trim stop sensor assembly.
- e. Check operation of electric trim stop sensor assembly. (Refer to Section IV.)

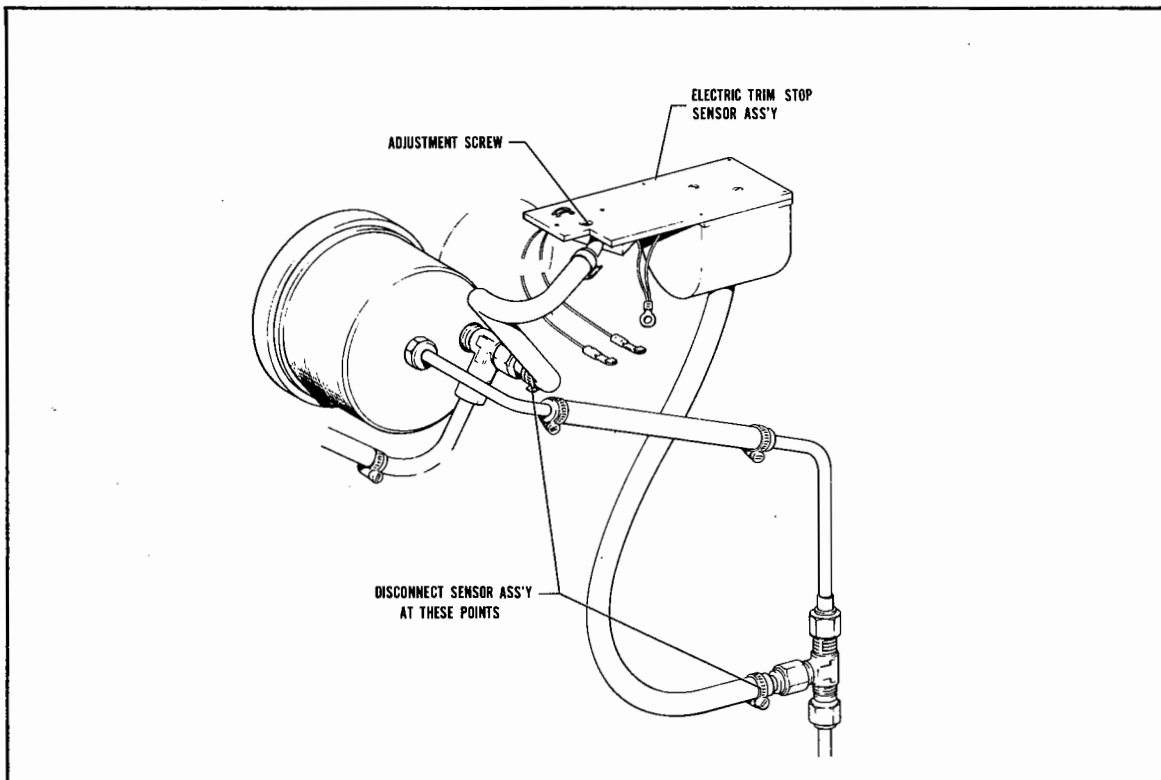

Figure 3-10. Electric Trim Stop Sensor Assembly Installation

SECTION IV

ADJUSTMENT PROCEDURES AND OPERATIONAL CHECKS

Paragraph		Page
4-1.	Description	4-1
4-2.	Control Wheel Harness Connections	4-1
4-3.	P. E. T. Servo Clutch Clearance Adjustment Procedure for Proper Clutch Torque	4-1
4-4.	Clutch Solenoid Coil Adjustment Procedure	4-2
4-5.	Adjustment of Servo Selector Switch and Pitch AutoPilot Servo Motor Switch	4-3
4-6.	Ground Checks for the P. E. T. Electric Pitch Trim Systems	4-4
4-7.	Flight Checks of the P. E. T. Electric Pitch Trim Systems	4-10
4-8.	Ground Check for Piper Electric Trim Stop Sensor Assembly (PA-28-181, PA-32R-300, PA-32RT-300 and PA-32RT-300T	4-13

SECTION IV

ADJUSTMENT PROCEDURES AND OPERATIONAL CHECKS

4-1. DESCRIPTION. This section provides the information necessary to properly adjust and perform operational checks of the P. E. T. Electric Pitch Trim Systems used in Piper airplanes. The first part of this section is comprised of servo adjustments and wiring connections for the control wheel trim switch. The second part consists of operational checks of the P. E. T. Electric Pitch Trim Systems.

Complete trim sensor contact centering procedures are described in Section III, Removal and Installation. Information pertaining to trim sensor adjustments can be obtained by referring to the particular type of sensor installation. The Trim Sensor Delay Circuit Check is also included in the Trim Sensor Centering adjustment instructions.

4-2. CONTROL WHEEL HARNESS CONNECTIONS. The pitch trim switch is mounted in the control wheel and is electrically connected to the components of the trim system through a coiled harness assembly. The connections for each installation is shown in illustration form in this section. When replacing a defective switch, refer to Figures 4-3 thru 4-5 for the proper wiring connections to be made on the airplane being serviced.

4-3. P.E.T. SERVO CLUTCH CLEARANCE ADJUSTMENT PROCEDURE FOR PROPER CLUTCH TORQUE. (Refer to Figure 4-1.)

- a. Check for .002" to .003" clearance with the trim servo disengaged.
- b. If clutch clearance is out of tolerance, remove cotter pin and rotate castle nut one (1) castellation in the desired direction and recheck clutch clearance.

NOTE

Clockwise rotation of nut decreases clutch clearance.
Counterclockwise rotation of nut increases clutch clearance.

c. If clutch clearance cannot be obtained when the castle nut is turned one (1) castellation from its original position, remove nut, washers, shims and capstan from shaft. Remove capstan carefully to avoid losing shims and washers. Interchange shims from the top and bottom of the capstan to obtain proper clutch clearance.

NOTE

Adding shims inside the capstan (BOTTOM) increases the clutch clearance. Removing shims from inside the capstan (BOTTOM) decreases the clutch clearance. Any shims removed from inside the capstan (BOTTOM) should be installed on top of the capstan for future use, if necessary.

- d. Reinstall capstan, shims, washers and nut.
- e. Tighten the capstan nut until the capstan just makes contact with the clutch clearance spring. Do not tighten the nut as this will compress the clutch clearance spring and lock the clutch disks together.
- f. Install cotter pin.

4-4. CLUTCH SOLENOID COIL ADJUSTMENT PROCEDURE. (Refer to Figure 4-1.)

NOTE

Use 14 VDC external power supply to insure sufficient solenoid current to develop maximum torque on clutch. Low battery voltage will cause low torque on the clutch even when the clutch is properly adjusted.

- a. Loosen four screws securing solenoid coil to the frame.
- b. Engage trim servo electrically to bottom the solenoid coil and mark the frame where the edge of coil is located while the trim servo is engaged electrically.
- c. Move the solenoid coil away from mark $1/16$ " to $1/8$ " and tighten the four coil mounting screws. Adjust the solenoid coil within the $1/16$ " to $1/8$ " dimension to obtain maximum clutch torque.

NOTE

Check that the coil is not cocked in the frame thereby causing friction between the solenoid slug and coil. Friction may cause clutch engage and/or disengage malfunctions.

- d. Engage servo electrically to check for maximum clutch torque by holding trim crank or wheel while electric trim is operating.

4-5. ADJUSTMENT OF SERVO SELECTOR SWITCH AND PITCH AUTOPILOT SERVO MOTOR SWITCH. (Refer to Figure 4-2.) This adjustment procedure is for AltiMatic II Installations containing the Rack and Pinion type servo. The cams used for adjustment of the switches are double stacked on the same retaining screw. The top cam adjustment is for the servo selector switch and the bottom cam adjustment is for the pitch servo motor switch. The following detailed adjusting procedures will explain the adjusting details for both switches. The switches are actuated by the AltiMatic II pitch engage knob. The cams must be adjusted so the top switch (servo selector switch) actuates when the AltiMatic II pitch engage knob is rotated through the 11:00 o'clock position and the bottom switch (AutoPilot servo motor switch) actuates when the AltiMatic II pitch engage knob is rotated through the 1:00 o'clock position. In addition, the bottom switch must actuate before the AutoPilot servo motor gears begin to mesh and both switches must deactuate before the AltiMatic II pitch engage knob is rotated to its OFF position.

NOTE

The adjustment of these switches must be accomplished in the airplane. The switch adjustment procedure can be accomplished in the PA-23 airplanes without removing the AltiMatic II Pitch Servo. In the PA-24 and PA-30 airplanes the AltiMatic II Pitch Servo must be removed to adjust these switches. Do not disconnect the servo engage flex cable. Refer to the I and II Series AutoPilot Service Manual Piper P/N 753 798 for AltiMatic II Pitch Servo Removal and Installation instructions. No provision is provided to adjust the switches on the chain type pitch AutoPilot servo.

- a. SWITCH ADJUSTMENT PROCEDURE. (Refer to Figure 4-2.)
1. Loosen cam screw slightly.

NOTE

If the cam screw is loosened excessively, cam adjustment will be more difficult. Use extreme caution when adjusting the cams to prevent damage to the follow-up condenser plates and switch springs.

2. Position the bottom cam so the bottom switch actuates when the AltiMatic II pitch engage knob is at the 1:00 o'clock position.
3. Hold the bottom cam in position and tighten the cam screw.
4. Rotate the AltiMatic II pitch engage knob through the 1:00 o'clock position and ascertain that the bottom switch actuates. If the switch fails to actuate at the 1:00 o'clock position repeat steps 1 thru 3 until the bottom switch is actuated when the pitch AutoPilot knob is rotated through the 1:00 o'clock position.
5. Hold the bottom cam in position and loosen cam screw slightly.
6. Position the top cam until the top switch actuates when the AltiMatic II pitch engage knob is at the 11:00 o'clock position.
7. Hold both cams in position and tighten the cam screw.
8. Ascertain that the top switch actuates when the AltiMatic II pitch engage knob is rotated to the 11:00 o'clock position and the bottom switch actuates when the AltiMatic II pitch engage knob is rotated to the 1:00 o'clock position. The bottom switch should actuate before the pitch servo gears start to engage and both switches should deactuate before the pitch engage knob is returned to its OFF position.

4-6. GROUND CHECKS FOR THE P. E. T. ELECTRIC PITCH TRIM SYSTEMS.

This section contains the information necessary to ground check the operation of P. E. T. Electric Pitch Trim Systems used in Piper airplanes. When using this section, be sure to utilize the tests that are appropriate to the type of system being serviced. The following checks are accomplished with the airplane master switch ON and the trim circuit breaker pushed IN. Schematics for the electrical circuits of the P. E. T. Electric Pitch Trim Systems are located in Section VI of this manual.

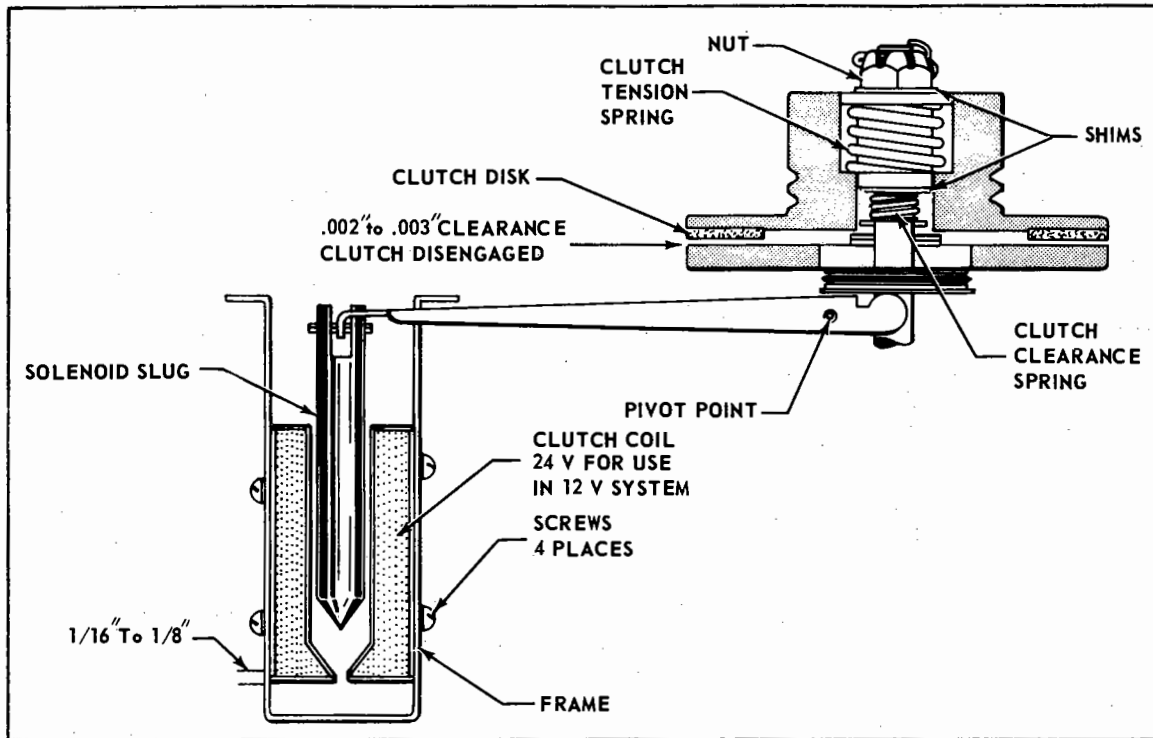

Figure 4-1. P.E.T. Trim Servo Clutch Adjustment

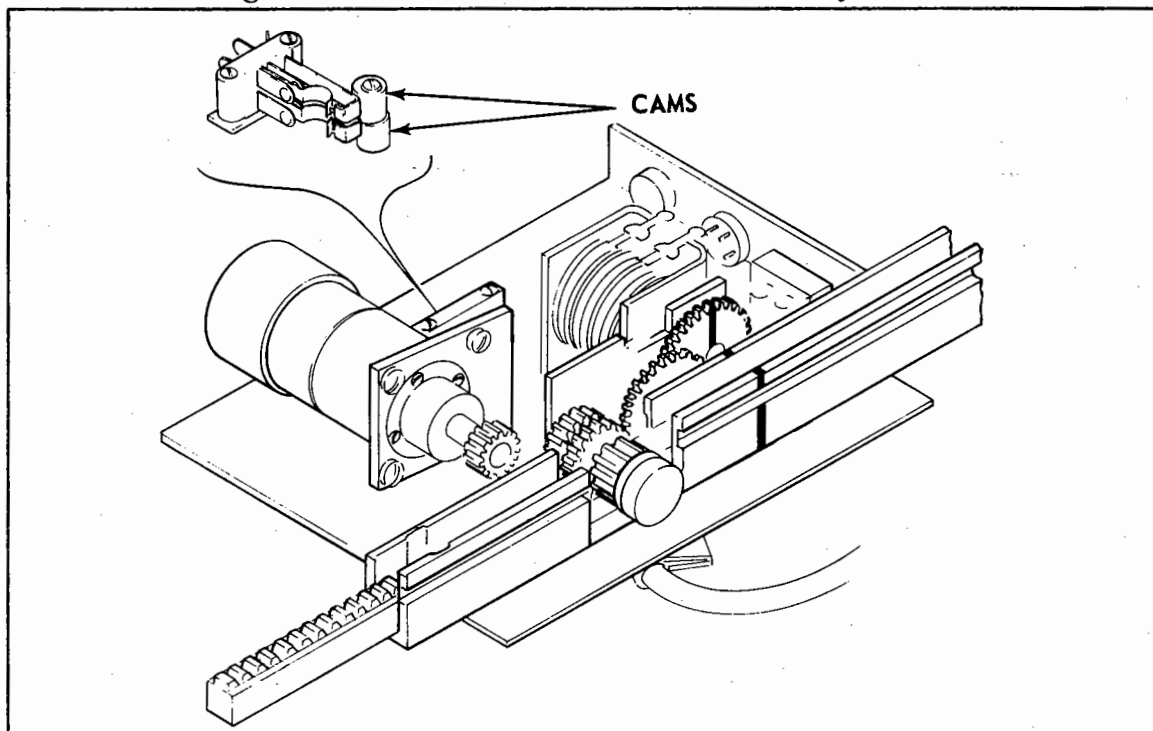

Figure 4-2. Switch Adjustment Cams

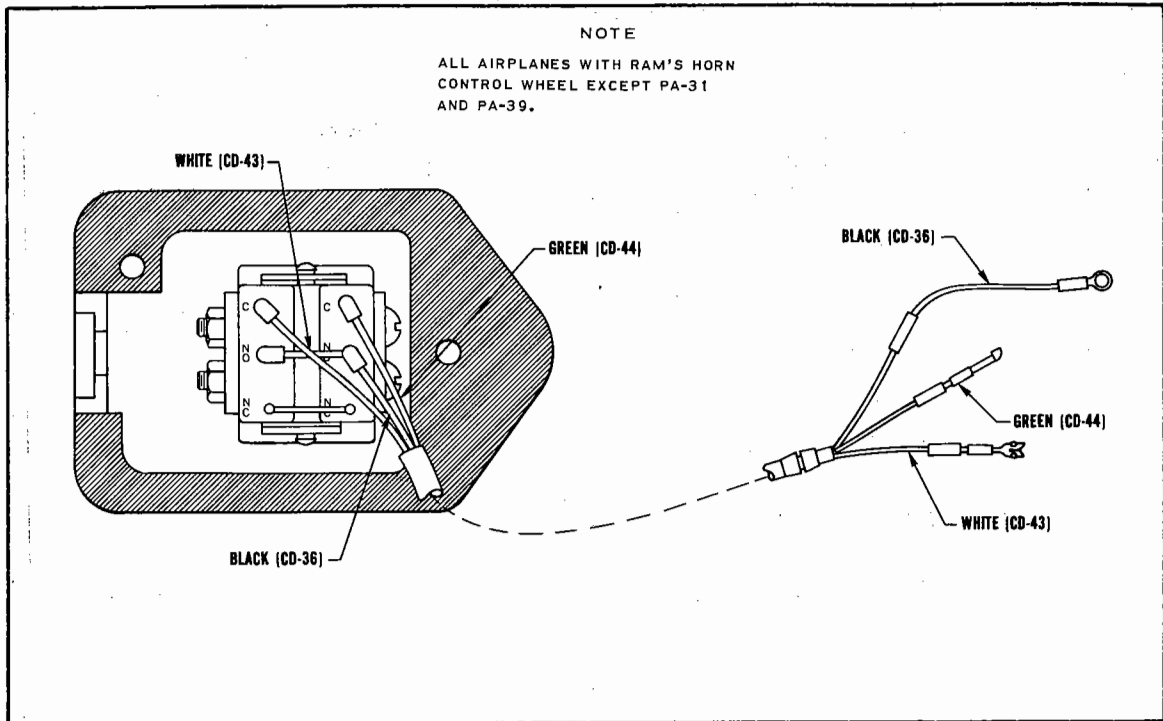

Figure 4-3. PA-23-250, PA-24 and PA-30
P. E. T. -1 Manual Electric Trim Control Wheel Switch

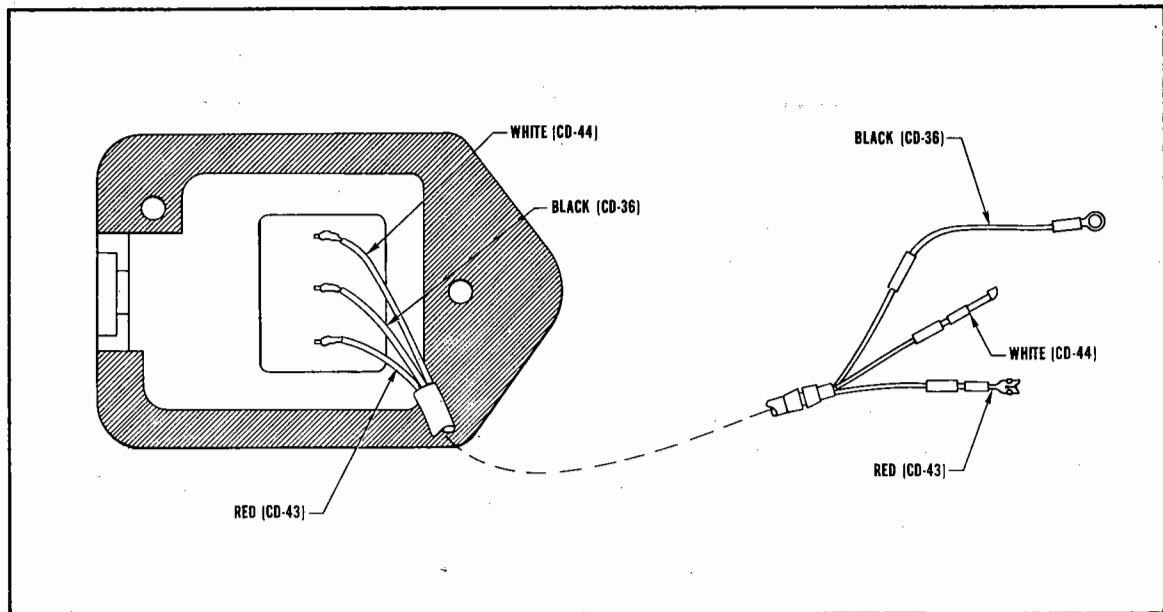

Figure 4-4. PA-23-250, PA-24 and PA-30
P. E. T. -1 Manual, P. E. T. -1 Automatic and P. E. T. -2
Automatic Electric Trim Control Wheel Switch

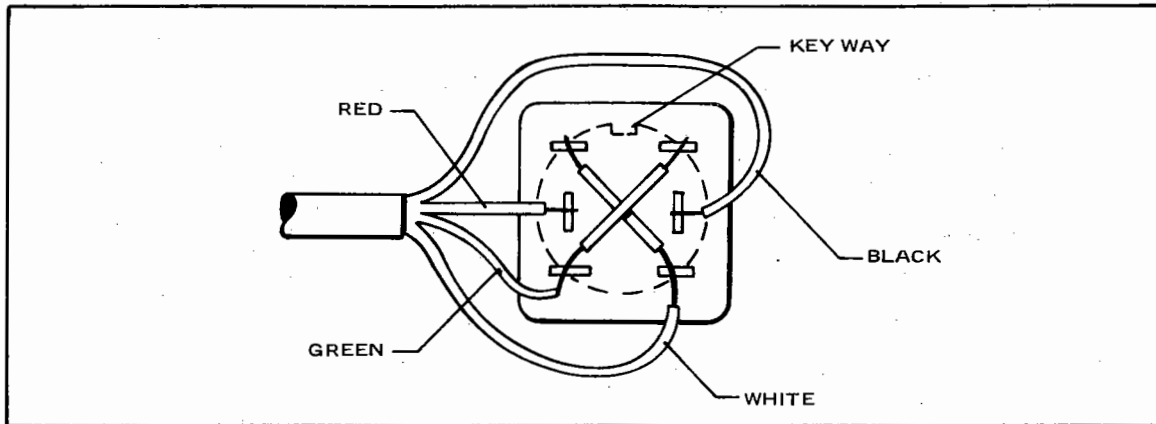

Figure 4-5. Manual Electric Trim Control Wheel Switch
 PA-28-140, Serial Nos. 28-20002 to 28-7525059 incl; PA-28-150, 160, and 180, Serial Nos. 28-1 to 28-4377 incl; PA-28-235, Serial Nos. 28-10003 to 28-11039 incl; PA-32-260, Serial Nos. 32-1 to 32-1110 incl; and PA-32-300, Serial Nos. 32-40000 to 32-40565 incl.

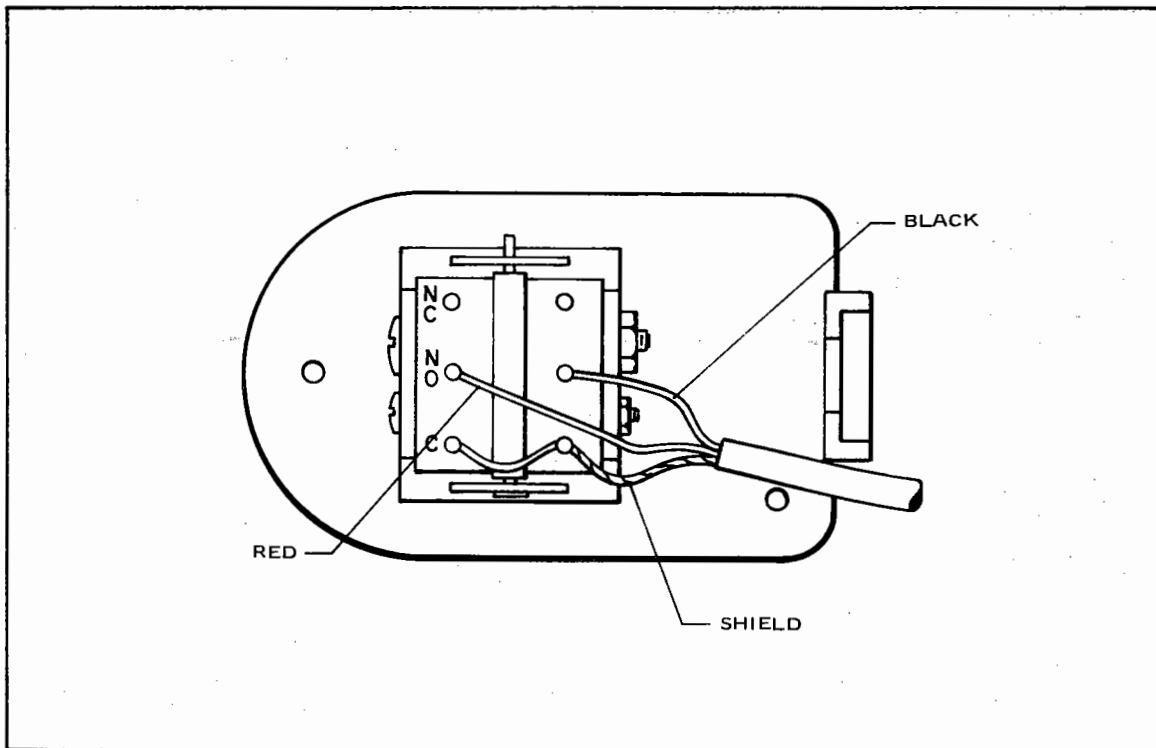

Figure 4-5 (cont.) Manual Electric Trim Control Wheel Switch
 PA-28-151, Serial Nos. 28-7415001 to 28-7515212 incl; PA-28-180, Serial Nos. 28-4378 to 28-7505079 incl; PA-28R-180, Serial Nos. 28-30005 and up; PA-28R-200, Serial Nos. 28-30482, 28-35001 to 28-7535077 incl; PA-28-235, Serial Nos. 28-11040 to 28-7510027 incl; PA-32-260, Serial Nos. 32-1111 to 32-7500008 incl; and PA-32-300, Serial Nos. 32-40566 to 32-7540058 incl.

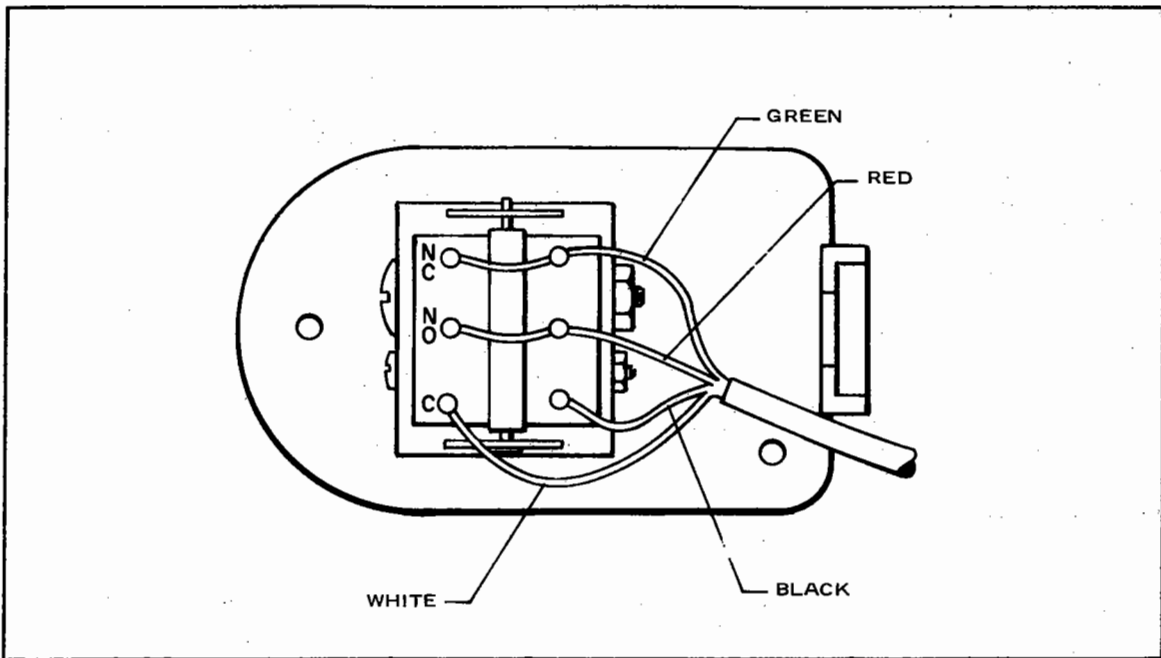

Figure 4-5 (cont.) Manual Electric Trim Control Wheel Switch

PA-28-151, Serial Nos. 28-7515213 and up; PA-28-161, Serial Nos. 28-7716001 and up; PA-28-180, Serial Nos. 28-7505080 and up; PA-28-181, Serial Nos. 28-7690001 and up; PA-28R-200, Serial Nos. 28R-7535078 and up; PA-28R-201, Serial Nos. 28R-7737001 and up; PA-28R-201T, Serial Nos. 28R-7703001 and up; PA-28-235, Serial Nos. 28-7510028 and up; PA-32-260, Serial Nos. 32-7500009 and up; PA-32-300, Serial Nos. 32-7540059 and up; PA-32R-300, Serial Nos. 32-7680001 and up; PA-32RT-300, Serial Nos. 32RT-7885001 and up; and the PA-32RT-300T, Serial Nos. 32RT-7887001 and up;

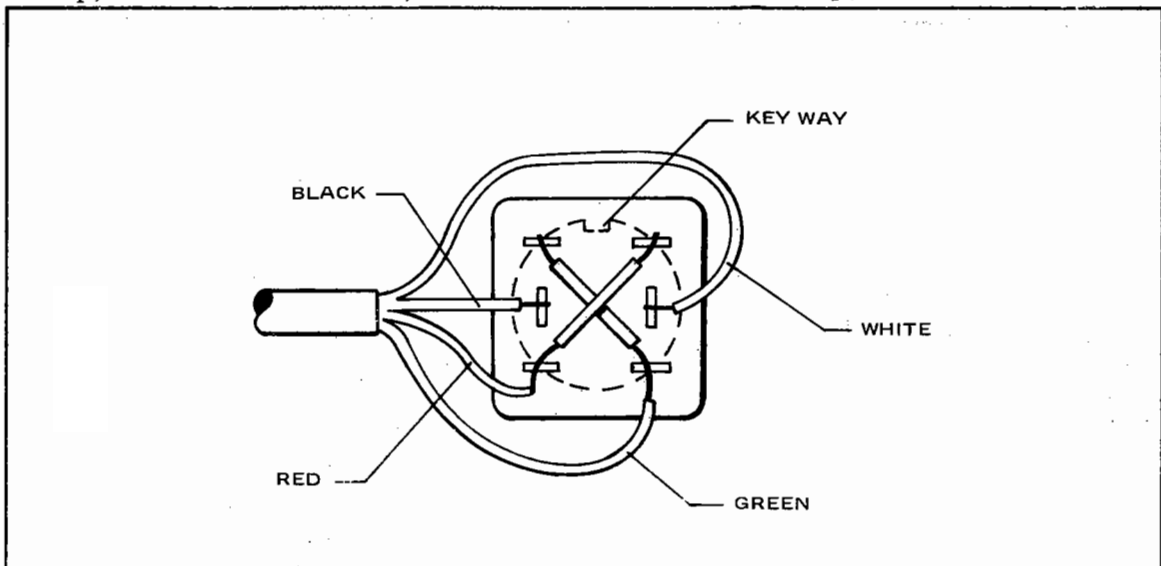

Figure 4-5 (cont.) Manual Electric Trim Control Wheel Switch

PA-28-140, Serial Nos. 28-7525096 and up

NOTE

In the event the trim servo does not drive the pitch trim system, it must be determined if the malfunction is mechanical or electrical. If mechanical malfunction, refer to Clutch Adjustment Procedure, Paragraph 4-3. If electrical, refer to Section VI and utilize the appropriate schematic to troubleshoot the trim system.

a. P. E. T.-1 MANUAL ELECTRIC TRIM SYSTEM.

1. Place the pitch trim at approximately neutral position.
2. Push the TRIM SWITCH to the NOSE DOWN position. The trim servo should drive the pitch trim NOSE DOWN.
3. Push the TRIM SWITCH to the NOSE UP position. The trim servo should drive the pitch trim NOSE UP.
4. While holding the trim switch in the NOSE DOWN or NOSE UP position, hold the trim crank or trim wheel to check that the trim servo clutch has adequate torque. If the clutch torque is low, refer to Paragraph 4-3 of this section for the trim servo clutch adjustment procedure.

b. P. E. T.-1 AUTOMATIC ELECTRIC TRIM SYSTEM—MANUAL MODE.

1. Place the pitch trim at approximately neutral position.
2. Rotate the AltiMatic II pitch engage knob to the OFF position.
3. With the PUSHBUTTON TRIM SWITCH released, apply FORWARD and AFT pressure on control wheel. The trim servo should not drive the pitch trim.
4. Depress the PUSHBUTTON TRIM SWITCH and apply FORWARD pressure on the control wheel. The trim servo should drive the pitch trim toward the NOSE DOWN position.
5. Release the FORWARD pressure on the control wheel. The trim servo may either STOP or continue driving the pitch trim toward the NOSE DOWN position.
6. Depress the PUSHBUTTON TRIM SWITCH and apply AFT pressure on the control wheel. The trim servo should drive the pitch trim toward the NOSE UP position.
7. Release the AFT pressure on the control wheel. The trim servo may either STOP or continue driving the pitch trim toward the NOSE UP position.

NOTE

If the trim servo reverses direction when the forward or aft pressure on the control wheel is released, the centering of the trim sensor contacts should be checked. Refer to Section III, Paragraph 3-22, for the trim sensor centering instructions.

c. P.E.T.-1 AUTOMATIC ELECTRIC TRIM SYSTEM—AUTOMATIC MODE.

1. Partially engage the AltiMatic II pitch axis by rotating the pitch engage knob to approximately 12 o'clock position.

NOTE

When the AltiMatic II pitch engage knob is at approximately 12 o'clock position, the pitch trim crank should be difficult to rotate which will confirm that the servo selector switch has switched the electric trim from the manual mode to the automatic mode. The clutch solenoid will be energized whenever the electric trim is in the automatic mode.

2. Rotate the trim handle to check that the trim servo clutch has adequate torque. If the clutch torque is low, refer to Paragraph 4-3 of this section for trim servo clutch adjustment procedure.
3. Apply FORWARD pressure on the control wheel. The trim servo should drive the pitch trim NOSE DOWN.
4. Release the FORWARD pressure on the control wheel. The trim servo may either STOP or continue driving the pitch trim NOSE DOWN.
5. Apply AFT pressure on the control wheel. The trim servo should drive the pitch trim NOSE UP.
6. Release the AFT pressure on the control wheel. The trim servo may either STOP or continue driving the pitch trim NOSE UP.

NOTE

If the trim servo reverses direction when the forward or aft pressure on the control wheel is released, the centering of the trim sensor contacts should be checked. Refer to Section III, Paragraph 3-22, for the trim sensor centering instructions.

7. Return the AltiMatic II pitch engage knob to the OFF position.
- d. P. E. T. -2 AUTOMATIC ELECTRIC TRIM SYSTEM—MANUAL MODE.
 1. Place the pitch trim at approximately neutral position.
 2. Place the AltiMatic II pitch engage knob to the OFF position.
 3. Push the TRIM SWITCH to the NOSE DOWN position. The trim servo should drive the pitch trim NOSE DOWN.
 4. Push the TRIM SWITCH to the NOSE UP position. The trim servo should drive the pitch trim NOSE UP.
 5. With the TRIM SWITCH in the neutral or OFF position, apply forward and aft pressure on the control wheel. The trim servo should not drive the pitch trim.
- e. P. E. T. -2 AUTOMATIC ELECTRIC TRIM SYSTEM—AUTOMATIC MODE.
 1. Partially engage the AltiMatic II pitch axis by rotating the pitch engage knob to approximately 12 o'clock position.

NOTE

When the AltiMatic II pitch engage knob is at approximately 12 o'clock position, the pitch trim crank should be difficult to rotate which will confirm that the servo selector switch has switched the electric trim from the manual mode to the automatic mode. The clutch solenoid will be energized whenever the electric trim is in the automatic mode.

2. Rotate the trim crank to check that the servo clutch has adequate torque. If the clutch torque is low, refer to Paragraph 4-3 of this section for the trim servo clutch adjustment procedure.
3. Apply FORWARD and AFT movement to the TRIM SWITCH. The trim switch should be inoperative.
4. Apply FORWARD pressure on the control wheel. The trim servo should drive the pitch trim NOSE DOWN.
5. Release the FORWARD pressure on the control wheel. The trim servo may either STOP or continue driving the pitch trim NOSE DOWN.
6. Apply AFT pressure on the control wheel. The trim servo should drive the pitch trim NOSE UP.
7. Release the AFT pressure on the control wheel. The trim servo may either STOP or continue driving the pitch trim NOSE UP.

NOTE

If the trim servo reverses direction when the forward or aft pressure on the control wheel is released, the centering of the trim sensor contacts should be checked. Refer to Section III, Paragraph 3-22, for the trim sensor centering instructions.

8. Return the AltiMatic II pitch engage knob to the OFF position.

4-7. FLIGHT CHECKS OF THE P. E. T. ELECTRIC PITCH TRIM SYSTEMS.

This section contains the information necessary to flight check the operation of the P. E. T. Electric Pitch Trim Systems used in Piper airplanes. When using this section, be sure to utilize the tests which are appropriate to the type of system being checked.

NOTE

In the event the trim servo does not drive the pitch trim system, it must be determined if the malfunction is mechanical or electrical. If mechanical malfunction, refer to Clutch Adjustment Procedure, Paragraph 4-3. If electrical, refer to Section VI and utilize the appropriate schematic to troubleshoot the trim system.

a. P. E. T. -1 MANUAL ELECTRIC TRIM SYSTEM.

1. Move the TRIM SWITCH on the pilot's control wheel to the forward or NOSE DOWN position.
2. The airplane should trim NOSE DOWN.
3. Release the TRIM SWITCH, it will return to the center or OFF position.
4. The electrical power used to drive the trim servo motor will be disconnected and the airplane will be trimmed NOSE DOWN until it is retrimmed to a new pitch attitude.
5. Move the TRIM SWITCH on the pilot's control wheel to the aft or NOSE UP position.
6. The airplane should trim NOSE UP.
7. Release the TRIM SWITCH, it will return to the center or OFF position.

8. The electrical power used to drive the trim servo motor will be disconnected, and the airplane will be trimmed NOSE UP until it is retrimmed to a new pitch attitude.

b. P.E.T. -1 AUTOMATIC ELECTRIC TRIM SYSTEM—MANUAL MODE.

1. Disengage the pitch axis of the AutoPilot.
2. Depress the PUSHBUTTON TRIM SWITCH on the pilot's control wheel. The airplane should trim in the correct direction until all pressure is relieved at the control wheel.

3. Release the PUSHBUTTON TRIM SWITCH. The airplane should fly at the trimmed pitch attitude.

4. With the PUSHBUTTON TRIM SWITCH depressed, pull AFT on the control wheel. The airplane should trim for a climb.

5. With the PUSHBUTTON TRIM SWITCH depressed, push FORWARD on the control wheel. The airplane should trim for a descent.

6. After establishing any pitch attitude, depress the PUSHBUTTON TRIM SWITCH. The electric trim should retrim to the airplane attitude.

c. P.E.T. -1 AUTOMATIC ELECTRIC TRIM SYSTEM—AUTOMATIC MODE.

1. Engage the pitch axis of the AutoPilot.
2. Anytime the AutoPilot changes the pitch attitude of the airplane or anytime a power change is made, the Automatic pitch trim will automatically retrim the airplane.

3. When the AltiMatic II pitch axis is disengaged, the airplane should be trimmed to the attitude at the time of AutoPilot disengagement. If an out of trim condition exists always in the same direction at the time of AutoPilot disengagement, the trim sensor centering should be checked, refer to Section III, Paragraph 3-22. If when disengaging the AutoPilot sometimes the airplane is in trim, sometimes it is trimmed NOSE UP or sometimes it is trimmed NOSE DOWN, check operation of the automatic mode of the electric pitch system.

NOTE

When engaging the AutoPilot, observe the trim crank. If the trim crank turns in either direction in excess of 1/3 of a complete turn, check the trim sensor centering in Section III, Paragraph 3-22.

d. P.E.T. -2 AUTOMATIC ELECTRIC TRIM SYSTEM—MANUAL MODE.

1. Disengage the pitch axis of the AutoPilot.
2. Move the TRIM SWITCH on the pilot's control wheel to the forward or NOSE DOWN position.
3. The airplane should trim NOSE DOWN.
4. Release the TRIM SWITCH. It will return to the center or OFF position.

5. The electrical power used to drive the trim servo motor will be disconnected and the airplane will continue to be trimmed NOSE DOWN until it is retrimmed to a new pitch attitude.

6. Move the TRIM SWITCH on the pilot's control wheel to the aft or NOSE UP position.

7. The airplane should trim NOSE UP.

8. Release the TRIM SWITCH, it will return to the center or OFF position.

9. The electrical power used to drive the trim servo motor will be disconnected and the airplane will continue to be trimmed NOSE UP until it is retrimmed to a new pitch attitude.

e. P. E. T. -2 AUTOMATIC ELECTRIC TRIM SYSTEM—AUTOMATIC MODE.

1. Engage the pitch axis of the AutoPilot.

2. Anytime the AutoPilot changes the pitch attitude of the airplane or anytime a power change is made the automatic pitch trim will automatically retrim the airplane.

3. When the AltiMatic II pitch axis is disengaged the airplane should be trimmed to the attitude at the time of AutoPilot disengagement. If an out of trim condition exists always in the same direction at the time of AutoPilot disengagement, the trim sensor centering should be checked, refer to Section III, Paragraph 3-22. If when disengaging the AutoPilot sometimes the airplane is in trim, sometimes it is trimmed NOSE UP or sometimes it is trimmed NOSE DOWN, check operation of the automatic mode of the electric pitch system.

NOTE

When engaging the AutoPilot, observe the trim crank. If the trim crank turns in either direction in excess of 1/3 of a complete turn, check the trim sensor centering in Section III, Paragraph 3-22.

4-8. GROUND CHECK AND ADJUSTMENT PROCEDURE FOR THE PIPER ELECTRIC TRIM STOP SENSOR ASSEMBLY. (PA-181, PA-32R-300, PA-32RT-300 and PA-32RT-300T.) This section consists of the information required to check and adjust the Piper Electric Trim Stop Sensor Assembly. This unit is incorporated in the PA-28-181, PA-32R-300, PA-32RT-300 and PA-32RT-300T, when the P.E.T.-1 is installed. The unit is located behind the left instrument panel. Refer to Section II, Removal and Installation to gain access to the unit.

a. TEST PROCEDURE FOR ELECTRIC TRIM STOP SENSOR ASSEMBLY.

1. Connect a suitable airspeed pressure simulator to the pitot head of the aircraft. Verify that there are no leaks present in the aircraft pitot system or the simulator.

2. Check the trim circuit breaker and place switch in the ON position.

3. Apply pressure with simulator to increase the aircrafts airspeed. When the airspeed increases to 166 ± 5 M.P.H. on the PA-28-181 or 195 ± 5 M.P.H. on the PA-32R-300, PA-32RT-300 and the PA-32RT-300T, actuate the trim switch in either direction. Trim should not operate. If trim operates proceed to step 5, if not, proceed to next step.

4. While holding the trim switch in the engaged position, reduce the simulator pressure to decrease the airspeed. Trim should operate when the airspeed is reduced below the specified settings as outlined in step 3. If trim fails to operate proceed to step 7.

5. While holding the trim switch in the engaged position, turn the adjustment screw (refer to Figure 4-8), as required, to obtain correct operation of electric trim stop sensor assembly.

NOTE

CLOCKWISE rotation of the adjustment screw will decrease the trim cut-off speed. COUNTERCLOCKWISE rotation of the adjustment screw will increase the trim cut-off speed.

6. If the serviceman is unable to adjust the unit in accordance with the specifications outlined in this procedure the unit should be replaced. Should a new unit be installed, reaccomplish this adjustment procedure.

7. Place the panel mounted pitch master switch in the OFF position and remove simulator.

8. This completes the adjustment procedure for the electric trim stop sensor assembly.

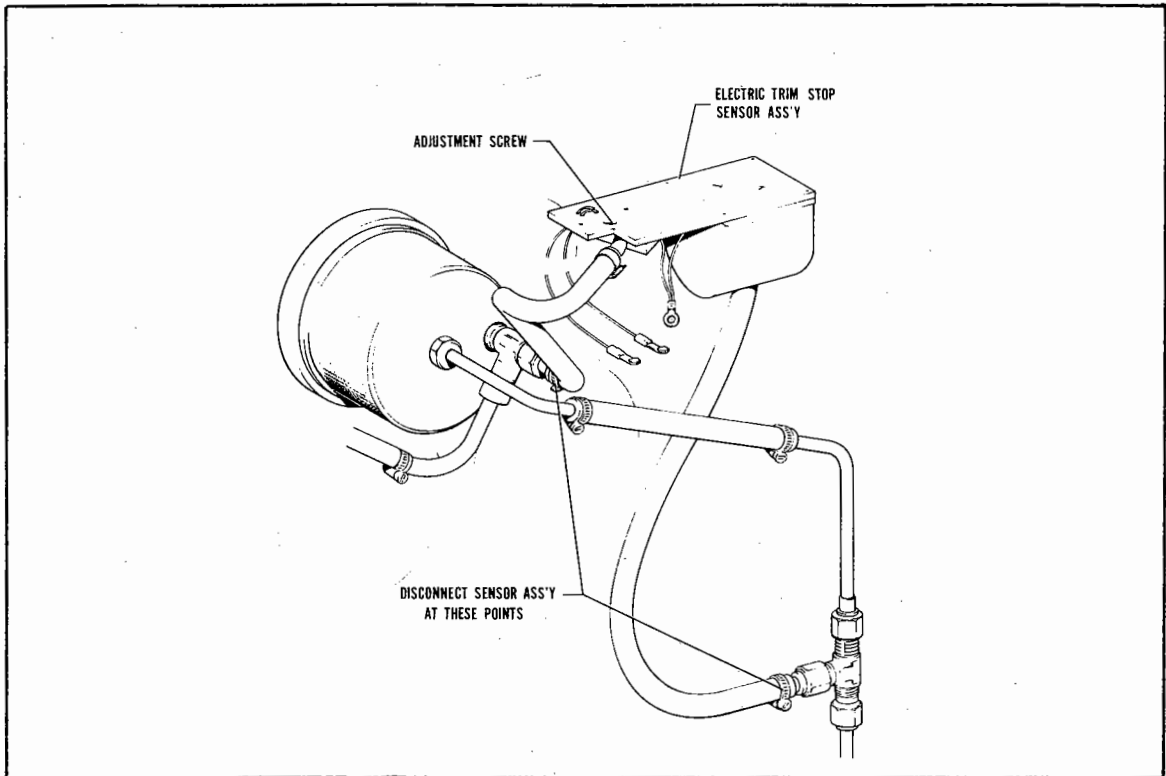

Figure 4-6. Electric Trim Stop Sensor Assembly

SECTION V

TEST EQUIPMENT

Paragraph		Page
5-1.	Introduction - #66B83-1 Output Meter	5-1

SECTION V

TEST EQUIPMENT

5-1. INTRODUCTION—#66B83-1 OUTPUT METER. (Refer to Figure 5-1.)

The Output Meter consists of a center reading meter, a dummy load resistor and an Alden receptacle to be used in conjunction with the Output Cable 30A177.

- a. This meter is used for the following purposes:
 - 1. Adjusting the "center" of the contact points on the P.E.T. Trim Sensor.
 - 2. Checking the trim sensor and amplifier circuitry for equal output.
 - 3. Checking the delay circuit of the trim amplifier.

NOTE

During prolonged use of the Output Meter, it will become hot due to the dummy load resistors dissipating the output of the trim amplifier which generates heat.

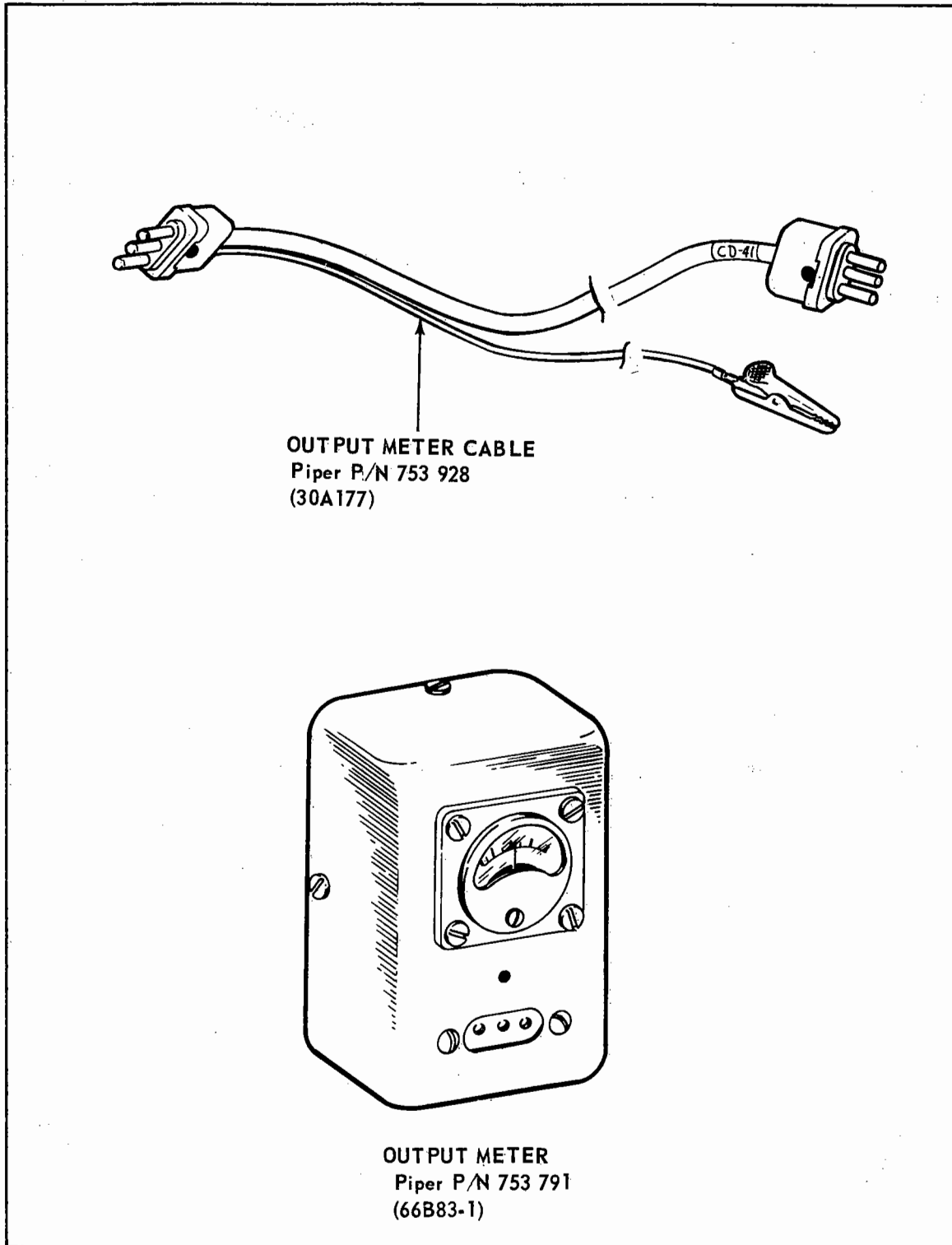

Figure 5-1. Test Equipment

SECTION VI

SCHEMATICS

Paragraph		Page
6-1.	Introduction.	6-1

SECTION VI

SCHEMATICS

6-1. INTRODUCTION. This section of the manual consists of schematic diagrams of the electrical circuitry of the P.E.T. Electric Trim Systems installed in Piper airplanes. When using this section ascertain the type of trim system being serviced and refer to the appropriate schematic. The schematic diagrams should be used as an aid in troubleshooting the electrical portion of the trim system.

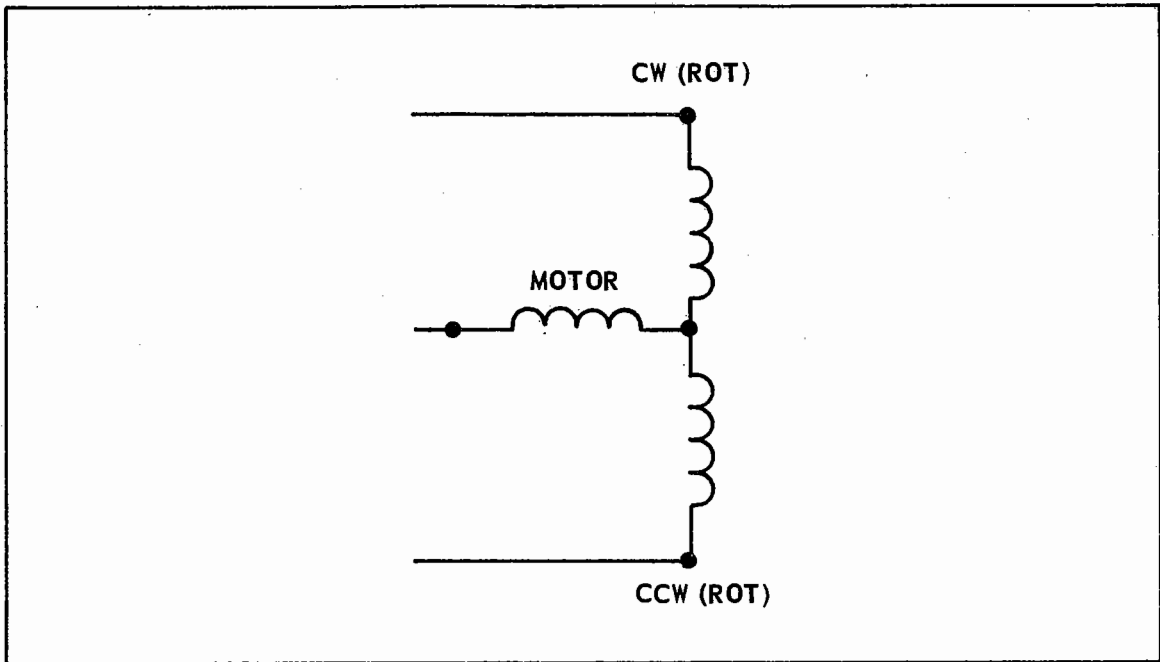

Figure 6-1. P.E.T. Series Pitch Trim Servo Motor Windings

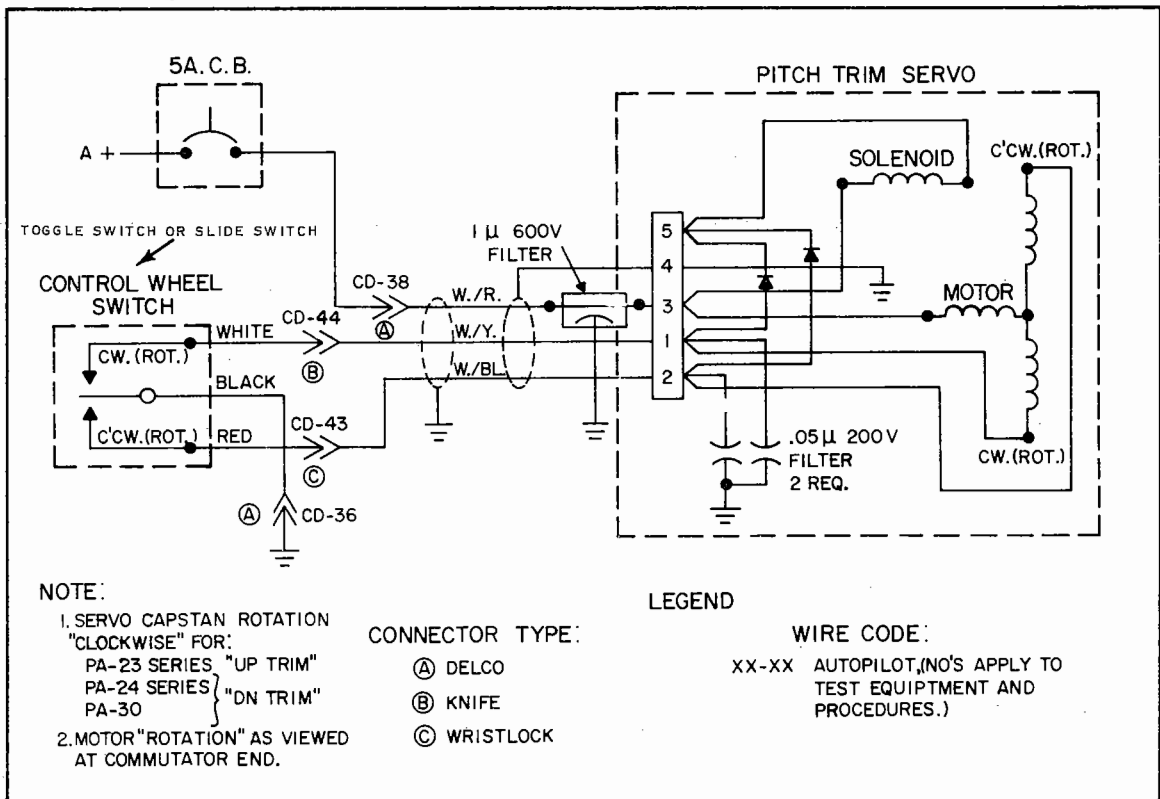

Figure 6-2. P.E.T. -1 Manual Electric Trim Schematic

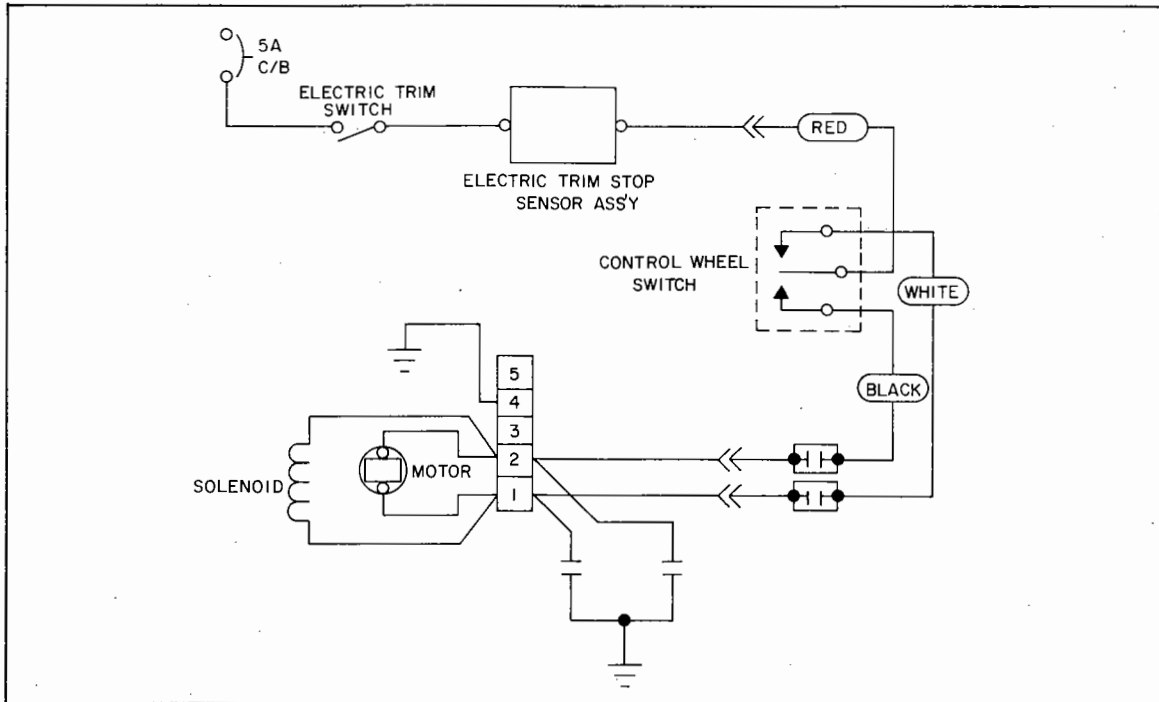

Figure 6-5. P.E.T.-1 Manual Electric Trim Schematic
(Electric Trim Stop Sensor PA-28-181, PA-32R-300, PA-32RT-300, and PA-32RT-300T.)

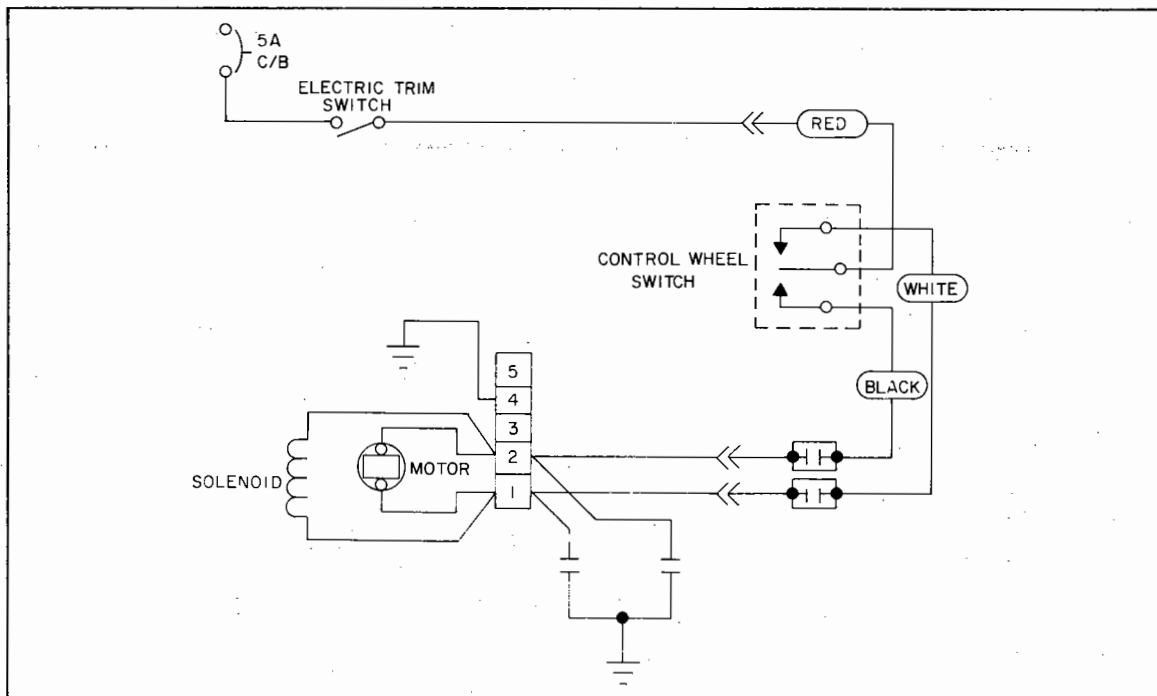

Figure 6-6. P.E.T.-1 Manual Electric Trim Schematic

PART II

ALTIMATIC III, IIIB AND IIIB-I ELECTRIC TRIM SYSTEMS

SECTION VII

INTRODUCTION AND DESCRIPTION

Paragraph		Page
7-1.	Introduction	7-1
7-2.	Description	7-1

SECTION VII

INTRODUCTION AND DESCRIPTION

7-1. INTRODUCTION. This part of the service manual is divided into six sections. Section VII contains a description of the III Series Automatic Electric Pitch Trim System. Section VIII, Theory of Operation, explains the modes of operation. Section IX, Removal and Installation, provides the information necessary for removal and installation of all trim components. Section X, Adjustment Procedures and Operational Checks, provides the information necessary to check the operation of the system and perform minor adjustments. Section XI, Test Equipment, describes the test equipment required to center the trim sensor contacts. Section XII, Schematics, provides the schematics of the trim systems for troubleshooting purposes.

7-2. DESCRIPTION. The III Series Automatic Electric Pitch Trim System is a system which trims the pitch axis of the airplane electrically. The operation of this system will be explained in Section VIII. It utilizes solenoid engage and incorporates the use of a permanent magnet type motor. This system uses a double pole, double throw switch on the control wheel.

NOTE

A simplified block diagram in Table VIII-I and an identifying features diagram in Table VIII-II is presented in Section VIII of this manual. These diagrams illustrate the basic components and features of the III Series Automatic Electric Pitch Trim System.

SECTION VIII

THEORY OF OPERATION

Paragraph		Page
8-1.	Description	8-1
8-2.	Trim Sensor Considerations	8-2
8-3.	Pitch Trim Warning System - III Series Automatic Electric Pitch Trim System.	8-3

SECTION VIII

THEORY OF OPERATION

8-1. DESCRIPTION. The III Series Automatic Electric Pitch Trim System has both a manual mode and an automatic mode of operation. The manual mode is operational only when the pitch axis of the AutoPilot is disengaged and the automatic mode is operational when the pitch axis of the AutoPilot is engaged. The switch that controls the mode of operation is located on the Pitch AutoPilot Servo on the AltiMatic II AutoPilot and is located in the AltiMatic III Series Console PITCH engage switches. A simplified block diagram of the III Series Automatic Electric Pitch Trim System is shown in Table VIII-I.

A differential cable tension sensing mechanism known as a Trim Sensor is incorporated in the various Automatic Electric Pitch Systems installed in Piper airplanes. There are two types of trim sensors installed in Piper airplanes, the plate type and pendulous type. The trim sensor consists of a set of adjustable electrical contacts which, when actuated by unequal elevator or stabilator cable tension, completes an electrical circuit in the trim amplifier. The trim amplifier converts the trim sensor signals into electrical power sufficient to drive the DC trim servo motor in the proper direction to correct an out of trim condition. The centering adjustment of the trim sensor contacts is of prime importance since the operation of the III Series Electric Pitch Trim System is dependent on the centering adjustment of the trim sensor. The reaction of the sensor contacts to both equal and unequal elevator or stabilator control cable tension is shown in illustration form, see Figure 8-1 thru 8-4. A detailed procedure on trim sensor contact centering is contained in Section IX, Paragraph 9-31.

Stabilator or elevator control cable tension is very important for the correct operation of the trim sensor. Low cable tension can cause insensitive trim sensor action and high cable tension can cause oversensitive trim sensor action. A substantial decrease in temperature can cause a decrease in cable tension, while a substantial increase in temperature will cause an increase in cable tension. This is caused by the unequal coefficient expansion between the aluminum in the airplane structure and the steel control cables. It is recommended that temperature be considered when adjusting or checking control cable tension. To insure that the control cable tension will remain within the tolerance specification published in the appropriate Airframe Service Manual. The high portion of the control cable tension specification should be used when checking or setting the control cable tension during extremely high temperatures. The

low portion of the control cable tension specification should be used when checking or setting the control cable tension during extremely low temperatures. This procedure will insure that the control cable tension will remain within the control cable tension specification for temperature variations.

8-2. TRIM SENSOR CONSIDERATIONS. The trim sensor used with a III Series trim system does not have an amplifier attached. The trim amplifier is installed on the trim servo and the trim sensor and amplifier are utilized ONLY in the AUTOMATIC MODE. A time delay circuit of one second is incorporated in the Automatic Mode.

a. III SERIES AUTOMATIC ELECTRIC PITCH TRIM SYSTEM - MANUAL MODE. This mode applies to the trim system when the pitch portion of the AutoPilot is disengaged. Trim may be accomplished by the human pilot electrically by use of the trim switch on the pilot's control wheel, which is a three position switch spring-loaded to the center or OFF position. There are two types of trim switches installed in Piper airplanes. On installations utilizing a separate control wheel mounted disengage button, movement of the switch in either direction will actuate the trim system. On installations having the disengage button incorporated in the control wheel mounted trim switch, the disengage button must be depressed when moving the switch in either direction to actuate the trim system. Also, the panel mounted and/or the control wheel mounted trim quick disconnect switch, when installed, must be pushed to the ON position. When operating the manual mode of the III Series Automatic Electric Pitch Trim System, keep in mind the different actuating procedure required for each trim switch. When the trim switch is moved to the forward position, it completes a circuit to the servo motor, supplying voltage of a proper polarity to assure rotation of the motor in the correct direction. At the same time, the switch supplies power to a solenoid which engages the trim servo motor to the capstan through a set of gears. Since the trim system cables are wrapped around the capstan, any rotation of the trim servo motor results in a change of position of the airplane's trim system, thus deflecting the stabilator or elevator trim tab in the conventional manner. When the human pilot releases the switch, it returns to the OFF position and power is then disconnected from the trim servo motor and the engage solenoid which completely disengages the electric trim motor from the airplane's trim system cables. If the switch is moved to the rear position, the same events occur except the polarity of the servo motor is reversed insuring the opposite direction of rotation.

b. III SERIES AUTOMATIC ELECTRIC PITCH TRIM SYSTEM - AUTOMATIC MODE. When the pitch axis of the AltiMatic II AutoPilot is engaged and the PITCH engage switch of the AltiMatic III Series Console is engaged, the switch on the pilot's control wheel becomes inoperative and electrical power is applied to the trim amplifier and pitch trim servo engage solenoid through the servo

console pitch engage switch. When the trim sensor detects a differential in stabilator or elevator cable tension caused by an out of trim condition, the "trim sensor" mechanically actuates a set of electrical contacts. These contacts complete an electrical circuit in the trim amplifier which converts the trim sensor signals into electrical power sufficient to drive the DC trim servo motor.

NOTE

The engage solenoid will maintain engagement of the servo motor and capstan gears continuously while the pitch axis of the AutoPilot is engaged.

8-3. PITCH TRIM WARNING SYSTEM - III SERIES AUTOMATIC ELECTRIC PITCH TRIM SYSTEM.

When the AltiMatic III Series Console is engaged, the Pitch Trim Warning System is operational. The function of this system is to provide the pilot with a visual indication of abnormally long or continuous Pitch Trim Servo operation. It consists of a compact electronic timing device mounted near the Pitch Trim Servo and an indicator light mounted on the instrument panel.

The electronic timing device is controlled by the trim sensor. When the sensor contacts remain closed in either position for longer than 3 to 4 seconds, the timing device actuates the indicator light on the instrument panel. When the sensor contacts open, even momentarily, the electronic timer resets and the indicator light goes out. During normal system operation if an occasional flash of the trim warning light is observed, this should not be mistaken for a system malfunction. If the indicator light stays on or flashes constantly, the trim system should be checked for misadjustment of sensor contacts, runaway pitch trim servo, servo clutch slipping or improper cable tension. The pitch trim system will normally maintain trim with servo operations of less than one second duration. The 3 seconds required to actuate the timing device is sufficient for proper system operation.

TABLE VIII-I. SIMPLIFIED BLOCK DIAGRAM
III SERIES AUTOMATIC ELECTRIC PITCH TRIM SYSTEM

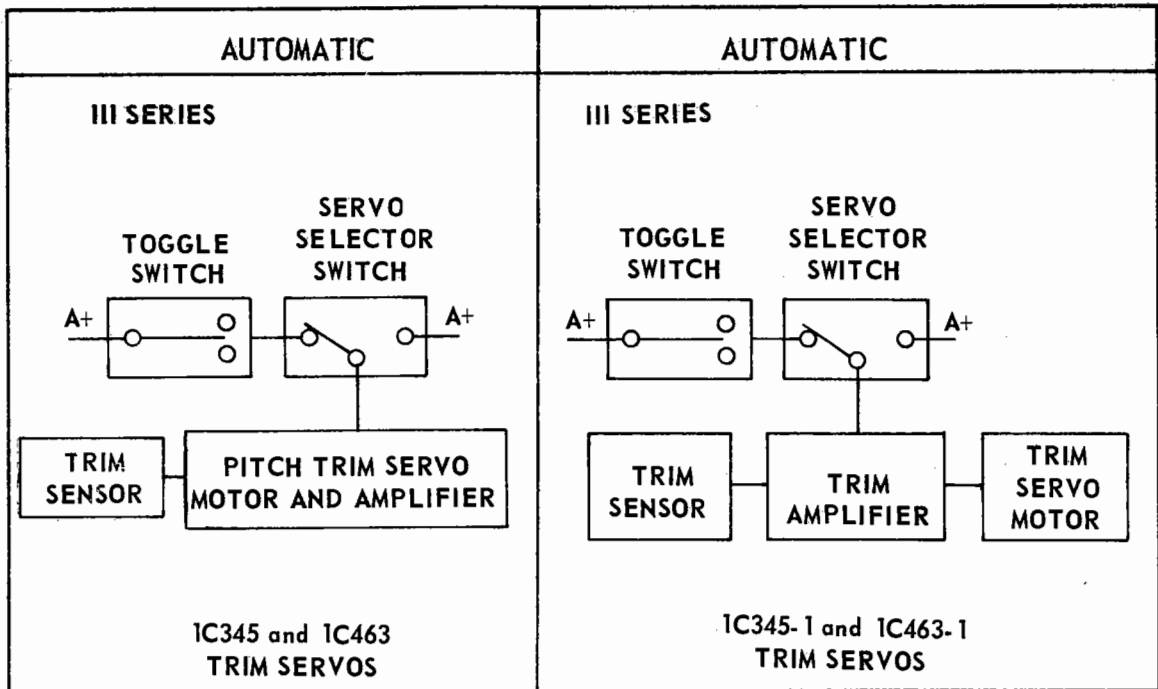

TABLE VIII-II. IDENTIFYING FEATURES
III SERIES AUTOMATIC ELECTRIC PITCH TRIM SYSTEM

AUTOMATIC
<p>III SERIES TOGGLE SWITCH OR SLIDE SWITCH ON CONTROL WHEEL TRIM SENSOR AMPLIFIER WITH TRIM SERVO PERMANENT MAGNET MOTOR NO DISK ON CAPSTAN TRIM SENSOR AND AMPLIFIER USED IN AUTOMATIC MODE ONLY</p>

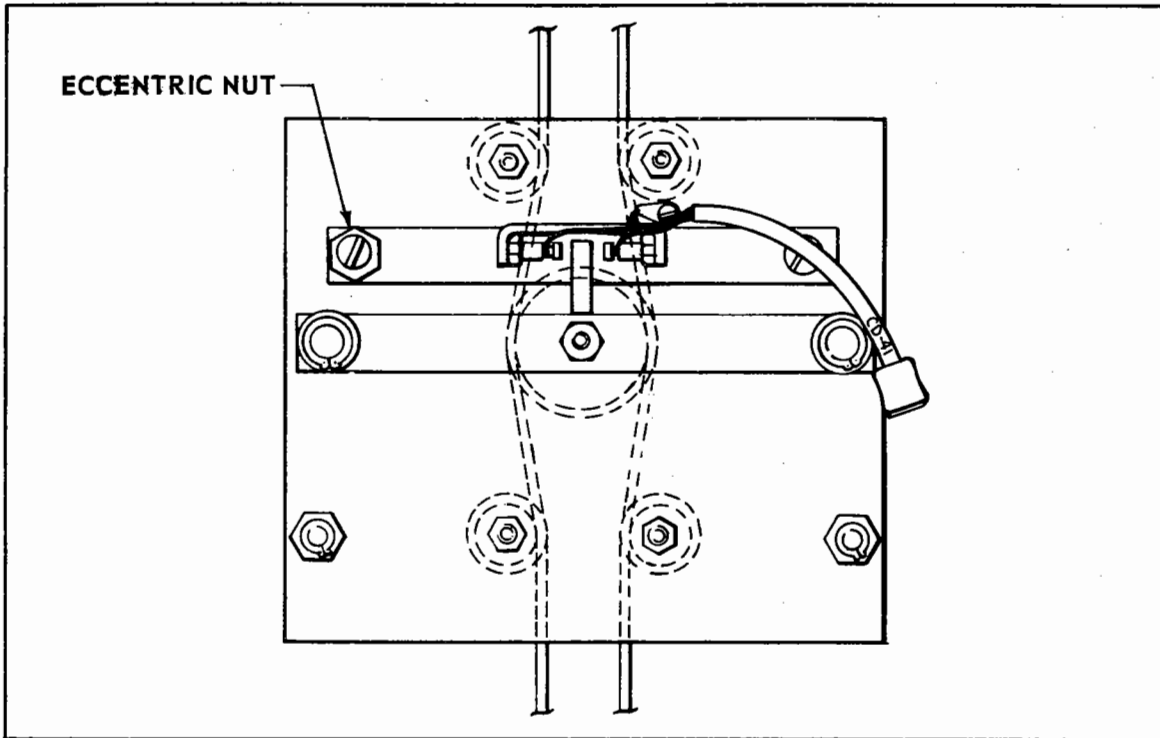

Figure 8-1. Plate Sensor Equal Elevator or Stabilator Cable Tension

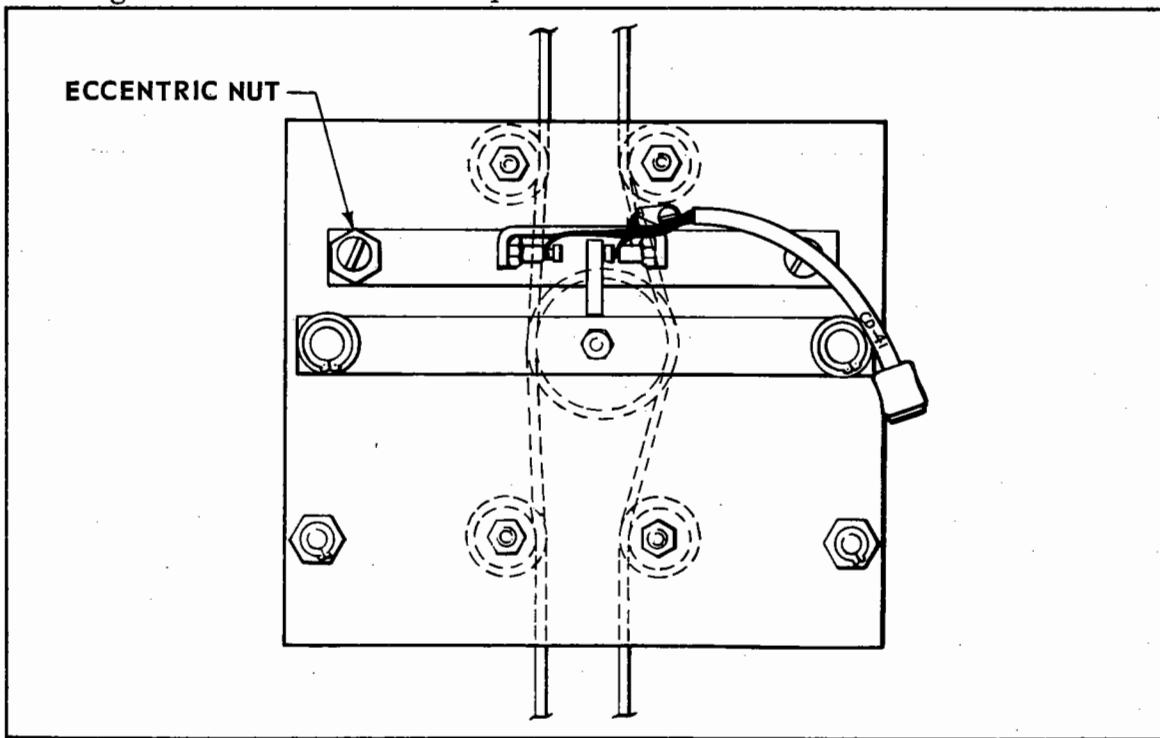

Figure 8-2. Plate Sensor Unequal Elevator or Stabilator Cable Tension

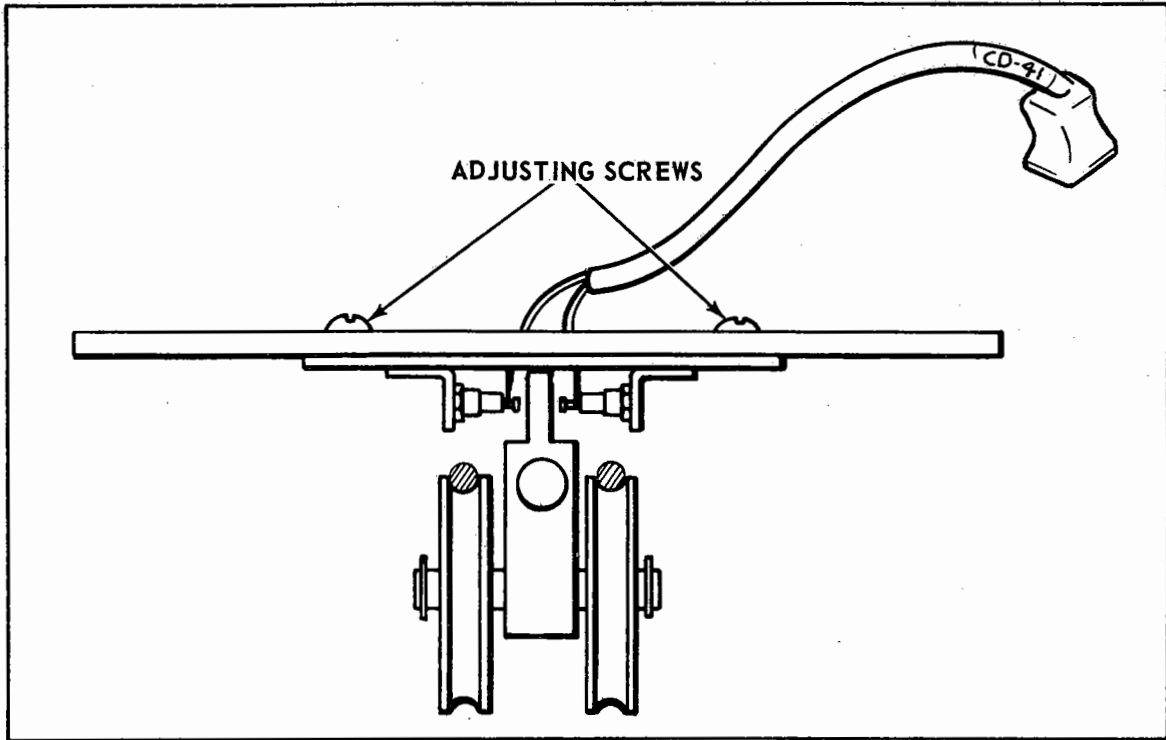

Figure 8-3. Pendulous Sensor Equal Elevator or Stabilator Cable Tension

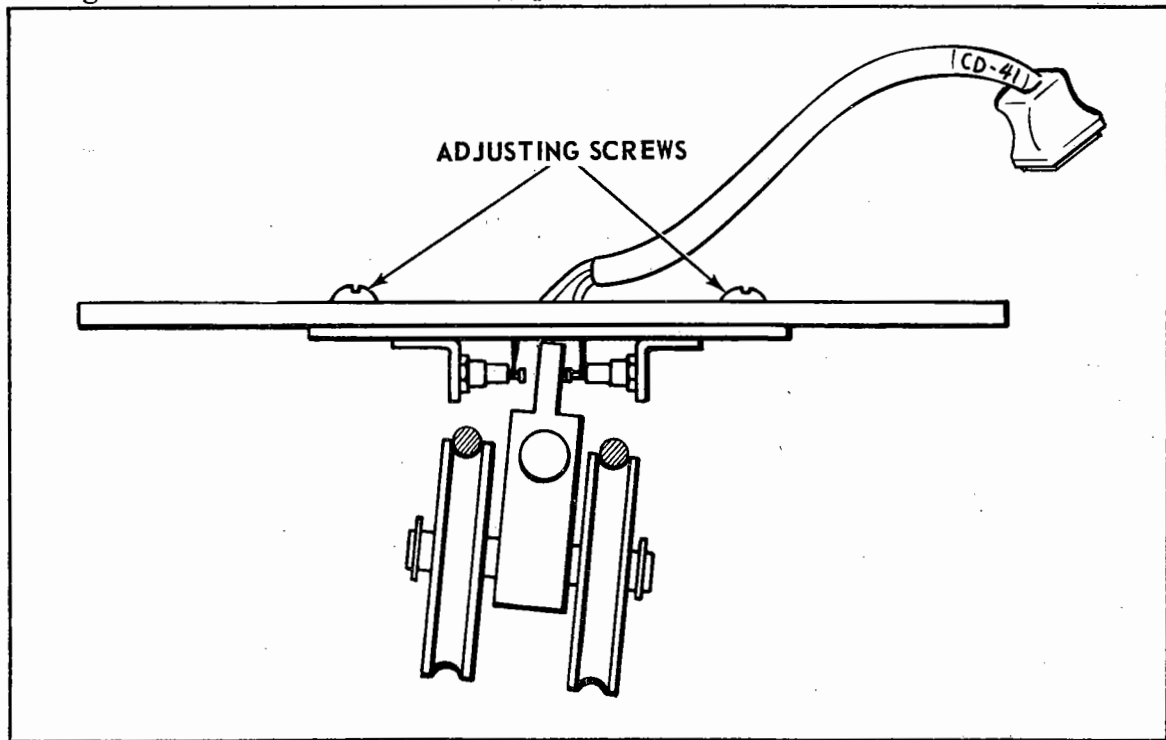

Figure 8-4. Pendulous Sensor Unequal Elevator or Stabilator Cable Tension

SECTION IX

REMOVAL AND INSTALLATION

Paragraph		Page
9-1.	Introduction	9-3
9-2.	Removal of Trim Servo - PA-23-250	9-3
9-3.	Installation of Trim Servo - PA-23-250	9-4
9-4.	Removal of Trim Amplifier on 1C345-1 Trim Servo - PA-23-250	9-4
9-5.	Installation of Trim Amplifier on 1C345-1 Trim Servo - PA-23-250	9-4
9-6.	Removal of Trim Sensor - PA-23-250	9-4
9-7.	Installation of Trim Sensor - PA-23-250	9-5
9-8.	Removal of Trim Servo - PA-24, PA-30 and PA-39	9-5
9-9.	Installation of Trim Servo - PA-24, PA-30 and PA-39	9-6
9-10.	Removal of Trim Amplifier on 1C345-1 Trim Servo - PA-24, PA-30 and PA-39	9-6
9-11.	Installation of Trim Amplifier on 1C345-1 Trim Servo - PA-24, PA-30 and PA-39	9-7
9-12.	Removal of Trim Sensor - PA-24, PA-30 and PA-39	9-7
9-13.	Installation of Trim Sensor - PA-24, PA-30 and PA-39	9-8
9-14.	Removal of Trim Servo - PA-31 and PA-31-350	9-11
9-15.	Installation of Trim Servo - PA-31 and PA-31-350	9-11
9-16.	Removal of Trim Amplifier on 1C463-1 Trim Servo - PA-31 and PA-31-350	9-12
9-17.	Installation of Trim Amplifier on 1C463-1 Trim Servo - PA-31 and PA-31-350	9-12
9-18.	Removal of Trim Sensor - PA-31 and PA-31-350	9-12
9-19.	Installation of Trim Sensor - PA-31 and PA-31-350	9-13
9-20.	Removal of Trim Servo - PA-31P	9-14
9-21.	Installation of Trim Servo - PA-31P	9-14
9-22.	Removal of Trim Amplifier - PA-31P	9-15
9-23.	Installation of Trim Amplifier - PA-31P	9-15
9-24.	Removal of Trim Sensor - PA-31P	9-15
9-25.	Installation of Trim Sensor - PA-31P	9-16
9-26.	Removal of Trim Servo - PA-32	9-18
9-27.	Installation of Trim Servo - PA-32	9-18
9-28.	Removal of Trim Sensor - PA-32	9-18
9-29.	Installation of Trim Sensor - PA-32	9-21
9-30.	Replacement of Trim Amplifier on 1D345 Trim Servo	9-21
9-31.	Trim Sensor Centering Procedures	9-22
9-32.	Removal of Trim Warning System	9-26

PIPER PITCH TRIM SERVICE MANUAL

9-33.	Installation of Trim Warning System	9-26a
9-34.	Removal of Trim Servo - PA-34-200	9-28
9-35.	Installation of Trim Servo - PA-34-200	9-28
9-36.	Removal of Trim Amplifier - PA-34-200	9-29
9-37.	Installation of Trim Amplifier - PA-34-200	9-29
9-38.	Removal of Trim Sensor - PA-34-200	9-29
9-39.	Installation of Trim Sensor - PA-34-200	9-29

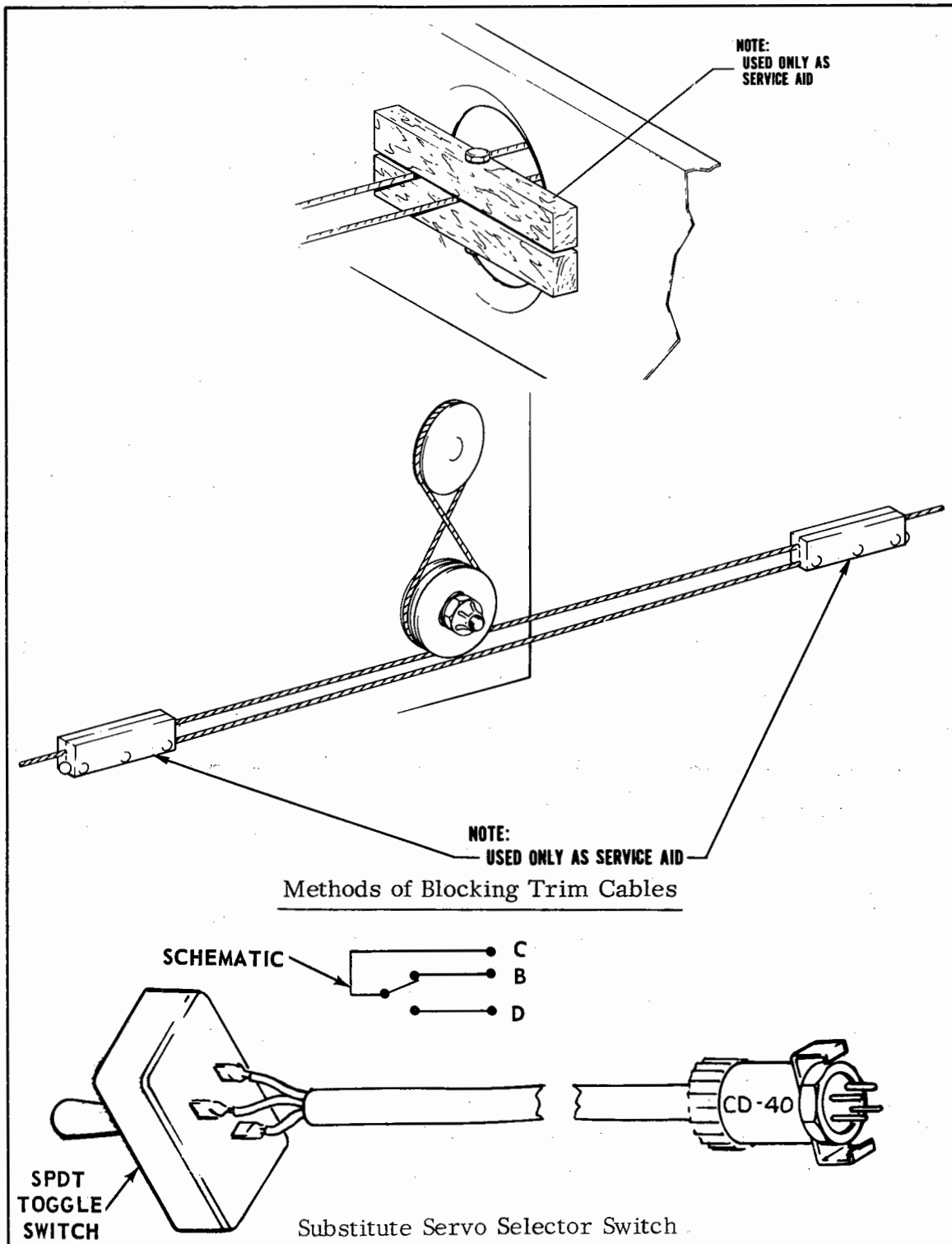

Figure 9-1. Servicing Aids

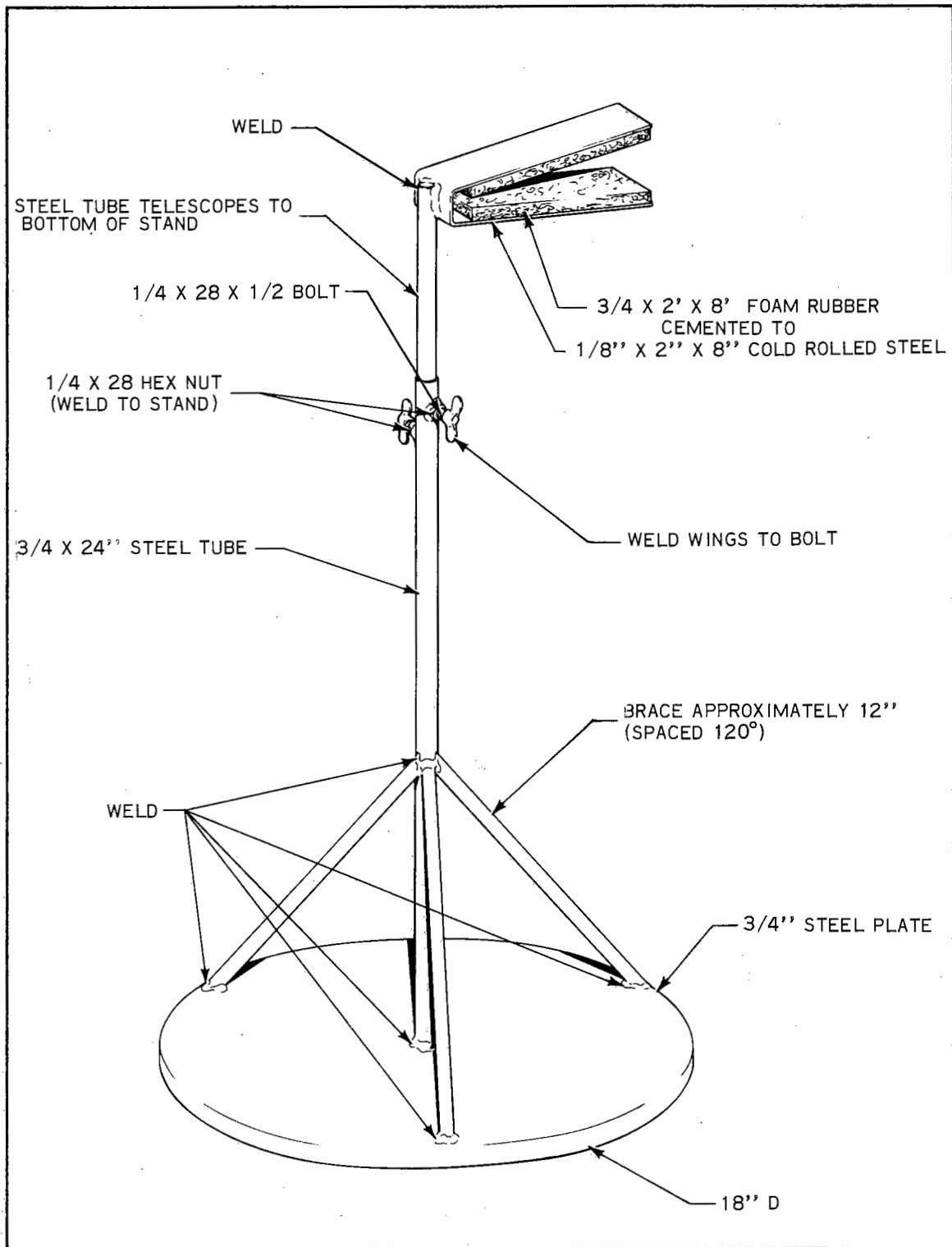

Figure 9-2. Typical Stabilator Holding Fixture

SECTION IX

REMOVAL AND INSTALLATION

9-1. INTRODUCTION. The information in this section describes the procedures for removal and installation of the components of the III Series Automatic Electric Pitch Trim System used in Piper airplanes. Included with the installation procedures are the necessary set-up and adjustment instructions. When any component of the trim system is installed a complete functional check of the entire trim system must be made to confirm correct system operation. When using this section refer to the type of component to be removed or installed. Refer to Paragraph 9-31 for Trim Sensor Contact Centering Procedures. To maintain cable routing of the trim cable during removal and installation of trim servos, it is recommended that the service aids shown in Figure 9-1 be utilized. Service aids as shown can be fabricated locally from shop material. The substitute Servo Selector Switch shown in Figure 9-1 can be fabricated from shop material. If in doubt about the operation of the Servo Selector Switch, the locally fabricated Servo Selector Switch may be substituted by connecting it to the trim cable CD-40 plug which is connected to the AutoPilot Pitch Servo on the II Series AutoPilots and on the console on the III Series AutoPilots.

9-2. REMOVAL OF TRIM SERVO. (PA-23-250.) The trim servo is located in the top aft baggage compartment.

- a. Access to the servo is through the aft baggage compartment door.
- b. Remove the box type trim panel forward of the baggage compartment dome light by removing six attaching screws.
- c. Remove the baggage area rear panel to gain access to the cable turnbuckles to release the tension on the cables.
- d. Disconnect electrical connections from the servo assembly.
- e. Remove four mounting bolts securing the servo assembly to the mounting brackets.
- f. Unwrap trim cable from capstan and idler pulley and remove servo assembly from the airplane.

9-3. INSTALLATION OF TRIM SERVO. (PA-23-250.) (Refer to Figure 9-3.)

- a. Position trim servo on the mounting brackets and secure with mounting bolts.
- b. Route the trim cable from the forward part of the airplane around the top capstan groove to the idler pulley and around the bottom capstan groove to the aft section of the airplane, completing a figure eight.
- c. Tighten the trim cable (on aircraft incorporating the Stabilator Bungee Spring Installation, the Bungee Spring must be disconnected when adjusting cable tension) to obtain appropriate tension as listed in Table IX-I.
- d. Connect electrical connections to trim servo assembly and check servo operation.
- e. Install baggage area rear panel and secure with attaching screws.
- f. Install box type trim panel forward of baggage compartment dome light and secure with attaching screws.

9-4. REMOVAL OF TRIM AMPLIFIER ON 1C345-1 TRIM SERVO. (PA-23-250.) The trim amplifier is located on the trim servo mounting plate in the top aft baggage compartment.

- a. Access to the trim amplifier is through the aft baggage compartment door.
- b. Remove the metal screws securing the headliner in the baggage compartment and remove headliner.
- c. Disconnect CD-41 and CD-45 electrical connections from trim amplifier.
- d. Disconnect CD-73 electrical connection from trim servo.
- e. Remove the two screws securing the trim amplifier to trim servo mounting plate.
- f. Remove the trim amplifier from the airplane.

9-5. INSTALLATION OF TRIM AMPLIFIER ON 1C345-1 TRIM SERVO. (PA-23-250.) (Refer to Figure 9-3.)

- a. Position the trim amplifier on the trim servo mounting plate and secure with appropriate screws.
- b. Connect the CD-41 and CD-45 electrical connections to trim amplifier.
- c. Connect the CD-73 electrical connection to trim servo and check servo operation.
- d. Install headliner in baggage compartment and secure with appropriate screws.

9-6. REMOVAL OF TRIM SENSOR. (PA-23-250.) The trim sensor is located on a mounting bracket under the main spar of the airplane.

- a. Remove the bottom fuselage panel aft of the nose gear doors by removing

screws securing panel.

- b. Cables on sensor can be removed by applying pressure to both cables and moving the cables out of trim sensor pulley grooves. If desired, the stabilator cable may be loosened to facilitate removing from the sensor.
- c. Disconnect the CD-41 electrical connection.
- d. Loosen nut under trim sensor plate at rear mounting screw and remove rear mounting screw, washer and nut from the trim sensor.
- e. Remove the screws securing the trim sensor to the mounting bracket.
- f. Remove the trim sensor from the airplane.

9-7. INSTALLATION OF TRIM SENSOR. (PA-23-250.) (Refer to Figure 9-4.)

- a. With the trim sensor pulleys facing down, route the stabilator control cables through the trim sensor pulleys. The trim sensor will center itself on the stabilator control cables.
- b. Position the trim sensor on the forward mounting bracket and secure with appropriate screws.
- c. Install screw, washer and nut in rear mounting hole.
- d. Adjust mounting screw and nut as required to align the trim sensor parallel with the stabilator control cables.
- e. Check stabilator control cables for proper tension as listed in Table IX-II.

NOTE

The outboard pulleys on the trim sensor must have freedom of rotation and vertical movement from their normal position when the trim sensor is properly aligned with the stabilator control cables.

- f. Refer to Paragraph 9-31 for trim sensor centering instructions.
- g. Connect the CD-41 electrical connection and perform the ground operational check of the Pitch Trim System as outlined in Section X, Paragraph 10-6.
- h. Install bottom fuselage panel previously removed and secure with appropriate screws.

9-8. REMOVAL OF TRIM SERVO. (PA-24, PA-30 and PA-39.) The trim servo is located aft of the baggage compartment on the upper fuselage.

NOTE

When servicing six-place airplanes, the 5th and 6th seats must be removed before proceeding with the following instructions.

- a. Access to the servo is through the baggage compartment.
- b. Remove attaching screws from left rear window trimstrip and remove trimstrip.
- c. Remove attaching screws from the hat shelf panel and remove panel by pushing right side of panel aft to force left side of panel forward to free panel from right rear window trimstrip.
- d. Remove attaching screws from rear baggage area panels and remove panels to gain access to turnbuckles to release cable tension.
- e. Disconnect electrical connections from the servo assembly.
- f. Remove four mounting bolts from trim servo assembly mounting bracket.
- g. Unwrap trim cable from the capstan and idler pulley and remove servo assembly from the airplane.

9-9. INSTALLATION OF TRIM SERVO. (PA-24, PA-30 and PA-39.) (Refer to Figure 9-3.)

- a. Position trim servo on mounting bracket and secure with mounting bolts.
- b. Route the trim cable from the forward part of the airplane around the top capstan groove to the idler pulley and around the bottom capstan groove to the aft section of the airplane, completing a figure eight.
- c. Tighten the trim cable to obtain appropriate tension as listed in Table IX-I.
- d. Connect electrical connections to trim servo assembly and check servo operation.
- e. Install rear baggage area panels and secure with attaching screws.
- f. Install hat shelf panel and left rear window trim strip and secure with attaching screws.

9-10. REMOVAL OF TRIM AMPLIFIER ON 1C345-1 TRIM SERVO. (PA-24, PA-30 and PA-39.) The trim amplifier is located on the Trim Servo Mounting Plate aft of the baggage compartment on the upper fuselage.

NOTE

When servicing six-place airplanes, the 5th and 6th seats must be removed before proceeding with the following instructions.

- a. Access to the trim amplifier is through the baggage compartment.
- b. Remove attaching screws from left rear window trimstrip and remove trimstrip.
- c. Remove attaching screws from the hat shelf panel and remove panel by pushing right side of panel aft to force left side of panel forward to free panel from right rear window trimstrip.
- d. Disconnect CD-41 and CD-45 electrical connections from trim amplifier.
- e. Disconnect CD-73 electrical connection from trim servo.
- f. Remove the two screws securing the trim amplifier to trim servo mounting plate.
- g. Remove trim amplifier from the airplane.

9-11. INSTALLATION OF TRIM AMPLIFIER ON 1C345-1 TRIM SERVO. (PA-24, PA-30 and PA-39.) (Refer to Figure 9-3.)

- a. Position the trim amplifier on the trim servo mounting plate and secure with appropriate screws.
- b. Connect the CD-41 and CD-45 electrical connections to trim amplifier.
- c. Connect the CD-73 electrical connection to trim servo and check servo operation.
- d. Install hat shelf panel and left rear window trimstrip and secure with attaching screws.

9-12. REMOVAL OF TRIM SENSOR. (PA-24, PA-30 and PA-39.)

NOTE

The trim sensor is beneath the forward access footwell panel of the center left seat. The center left seat must be removed to gain access to sensor.

- a. Remove carpet from footwell.
- b. Remove forward access panel of footwell by removing attaching screws.
- c. The cables on the trim sensor can be removed by applying pressure to both cables and moving the cables out of the trim sensor pulley grooves. If desired, the stabilator cable may be loosened to facilitate removing from the sensor.
- d. Disconnect the CD-41 electrical connection.
- e. Loosen nut under trim sensor plate at rear mounting screw and remove rear mounting screw, washer and nut from the trim sensor.
- f. Remove the screws securing the trim sensor to the mounting bracket.
- g. Remove the trim sensor from the airplane.

9-13. INSTALLATION OF TRIM SENSOR. (PA-24, PA-30 and PA-39.) (Refer to Figure 9-4.)

- a. With the trim sensor pulleys facing down, route the stabilator control cables through the trim sensor pulleys. The trim sensor will center itself on the stabilator control cables.
- b. Position the trim sensor on the forward mounting bracket and secure with appropriate screws.
- c. Install screw, washer and nut in rear mounting hole.
- d. Adjust mounting screw and nut as required to align the trim sensor parallel with the stabilator control cables.
- e. Check stabilator control cables for proper tension as listed in Table IX-II.

NOTE

The outboard pulleys on the trim sensor must have freedom of rotation and vertical movement from their normal position when the trim sensor is properly aligned with the stabilator control cables.

- f. Refer to Paragraph 9-31 for trim sensor centering instructions.
- g. Connect the CD-41 electrical connection and perform the ground operational check of the Pitch Trim System as outlined in Section X, Paragraph 10-6.
- h. Install forward footwell access panel and secure with attaching screws.
- i. Install footwell carpet and appropriate seat previously removed.

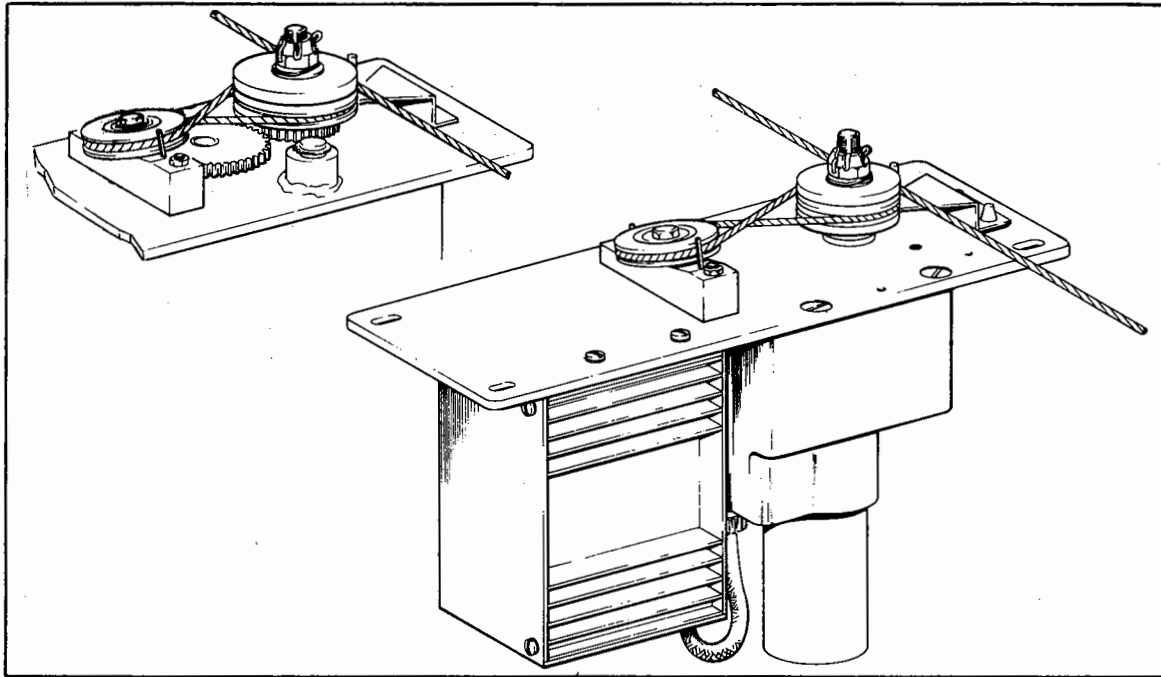

Figure 9-3. PA-23-250, PA-24, PA-30 and PA-39 Trim Servo Cable Routing

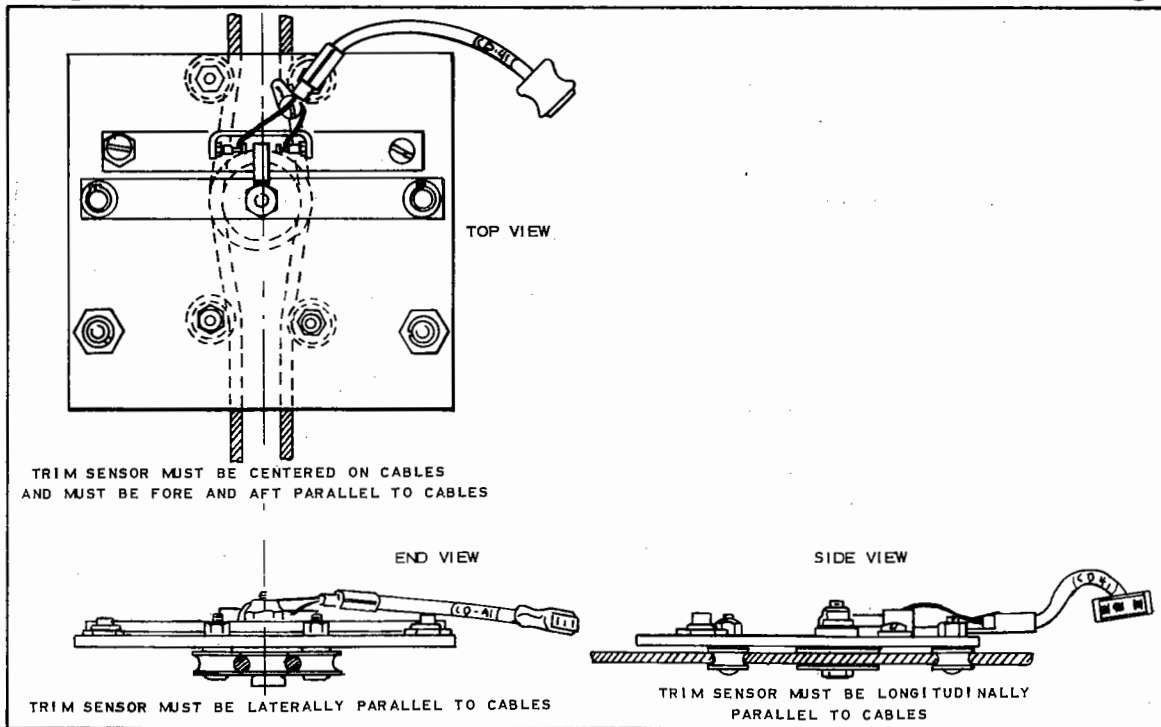

Figure 9-4. PA-23-250, PA-24, PA-30, PA-31P, PA-32, PA-34-200 and PA-39 Trim Sensor

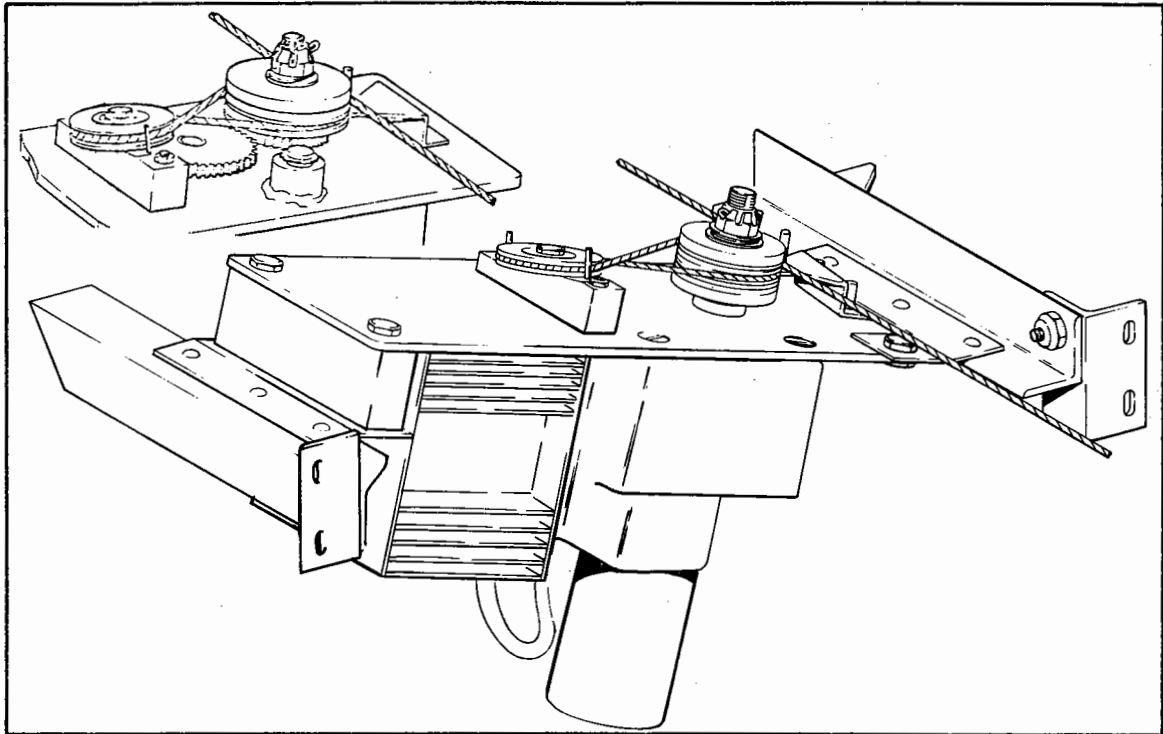

Figure 9-5. PA-31 Trim Servo Cable Routing

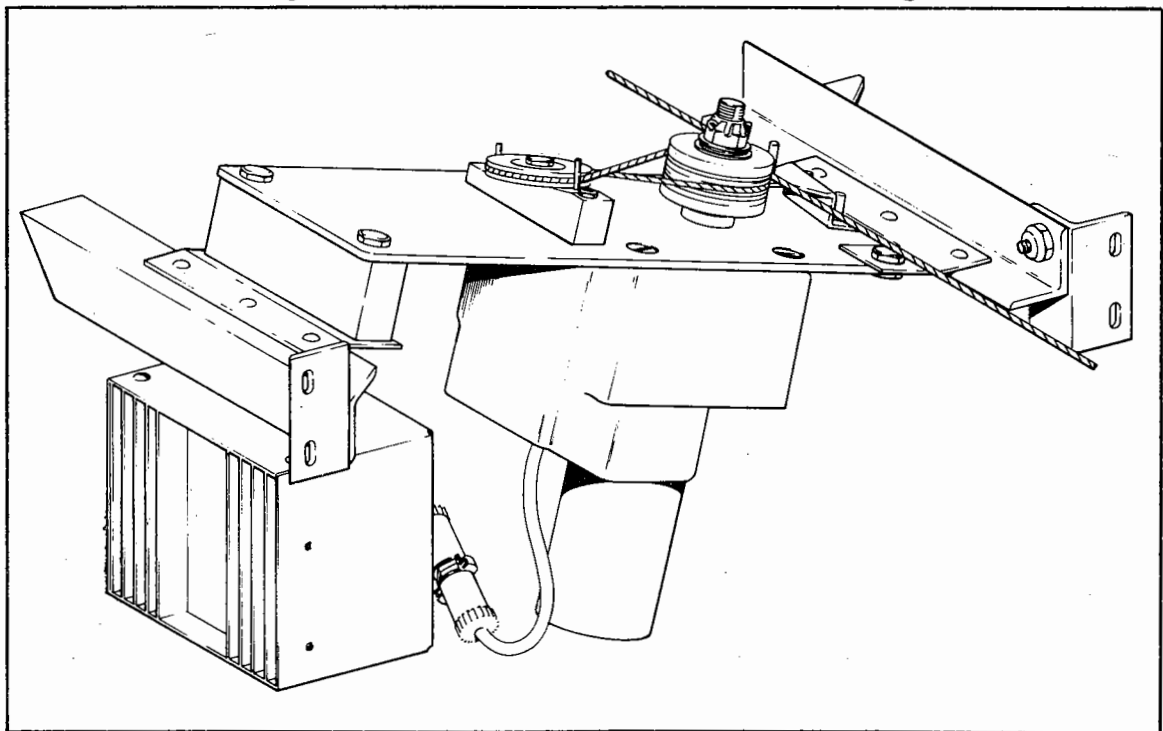

Figure 9-6. PA-31 and PA-31-350 Trim Servo Cable Routing

9-14. **REMOVAL OF TRIM SERVO.** (PA-31 and PA-31-350.) The trim servo is located between sta. 174 and sta. 181 beneath the center and right aft floorboard panels.

NOTE

Depending on airplane being serviced, the following instructions should be utilized. If the trim servo and trim amplifier are mounted separately, service can be completed on either one without removing both components from the airplane.

- a. Remove passenger seats on right side of airplane.
- b. Remove carpet from center and right side of passenger section.
- c. Remove center and right aft floorboard panels by removing attaching screws.
- d. Release elevator cable tension.
- e. Unwrap trim cable from capstan and idler pulley.
- f. **DEICER INSTALLED.** If the airplane is equipped with deicers, remove the section of deicer line located between the two bulkheads at the trim servo. It is recommended that a protective covering be placed over the open ends of the deicer line to prevent contamination.
- g. Remove bolts securing trim servo to the mounting bracket.
- h. Disconnect electrical connections from the servo assembly.
- i. Remove trim servo from the airplane.

9-15. **INSTALLATION OF TRIM SERVO.** (PA-31 and PA-31-350.) (Refer to Figures 9-5 and 9-6.)

- a. When making this installation, keep in mind the possibility of the different assemblies referred to in the preceding "NOTE", reference Paragraph 9-14.
- b. Position trim servo on the mounting brackets.
- c. Secure trim servo to the mounting brackets with appropriate screws or bolts.
- d. Route the trim cable from the forward part of the airplane around the top capstan groove to the idler pulley and around the bottom capstan groove to the aft section of the airplane, completing a figure eight.
- e. Tighten the trim cable to obtain appropriate tension as listed in Table IX-I.
- f. Connect electrical connections to trim servo assembly and check servo operation.
- g. If airplane is equipped with deicers, install the section of deicer line previously removed.
- h. Install center and right aft floorboard panels and secure with attaching screws.
- i. Install carpet and seats previously removed in passenger section.

9-16. REMOVAL OF TRIM AMPLIFIER ON 1C463-1 TRIM SERVO. (PA-31 and PA-31-350.) The trim amplifier is located between sta. 174 and sta. 181 beneath the center aft floorboard panel.

NOTE

On PA-31 airplanes the trim amplifier is mounted on either the trim servo mounting plate or the bulkhead near the trim servo.

- a. Remove passenger seats on right side of the airplane.
- b. Remove carpet from center of passenger section.
- c. Remove center aft floorboard panel by removing attaching screws.
- d. Disconnect CD-41 and CD-45 electrical connections from the trim amplifier.
- e. Disconnect CD-73 electrical connection from the trim servo.
- f. Remove the two mounting screws securing the trim amplifier to the trim servo mounting plate or the bulkhead.
- g. Remove the trim amplifier from the airplane.

9-17. INSTALLATION OF TRIM AMPLIFIER ON 1C463-1 TRIM SERVO. (PA-31 and PA-31-350.) (Refer to Figures 9-5 and 9-6.)

- a. Position the trim amplifier on the trim servo mounting plate or the bulkhead and secure with appropriate screws.
- b. Connect the CD-41 and CD-45 electrical connections to the trim amplifier.
- c. Connect the CD-73 electrical connection to the trim servo and check servo operation.
- d. Install center aft floorboard panel and secure with attaching screws.
- e. Install carpet and seats previously removed in passenger section.

9-18. REMOVAL OF TRIM SENSOR. (PA-31 and PA-31-350.) The trim sensor is located in the center of the fuselage beneath the aft access panel in the floorboard near the main entrance door.

NOTE

Depending on the type of interior finish found in PA-31 airplane being serviced, the seats, refreshment bar, or both, installed in the airplane between sta. 229 and 244, must be removed. The carpet can then be rolled back to permit the removal of the access plate covering the trim sensor. Access to sensor can be gained by the following instructions:

- a. Enter the main entrance door and roll back the carpet.
- b. Remove the attaching screw from the access panel in the center aft section of the floorboard located from sta. 215 to sta. 244 and remove panel.
- c. Remove stabilator or elevator cables from the sensor pulleys. This is accomplished by lifting the cables above the pulley flanges and moving them to the outside of the pulleys.
- d. Disconnect CD-41 electrical connection.
- e. Remove screws securing the trim sensor mounting blocks to the fuselage skin.
- f. Remove the trim sensor from the airplane.

9-19. INSTALLATION OF TRIM SENSOR. (PA-31 and PA-31-350.) (Refer to Figure 9-7.)

- a. Position the trim sensor and mounting blocks and secure to the skin with the appropriate screws.
- b. Place stabilator or elevator cables on top of the trim sensor pulleys. When placing cables on pulleys, ascertain that cables are raised high enough to prevent the pulley edges from being broken.

NOTE

The pulleys on the Pendulous Trim Sensor should have horizontal travel from their normal position when the trim sensor is properly aligned with the stabilator cables.

- c. Check elevator cables for proper tension as listed in Table IX-II.
- d. Refer to Paragraph 9-31 for trim sensor centering instructions.
- e. Connect the CD-41 electrical connection and perform ground operational check of the Pitch Trim System.
- f. Install access panel and secure with attaching screws.
- g. Replace carpet and secure.
- h. Replace any interior components previously removed.

9-20. REMOVAL OF TRIM SERVO. (PA-31P.) The trim servo is located between sta. 174 and sta. 181 beneath the center and right floorboard panels aft of the main spar.

- a. Remove passenger seats on right side of airplane.
- b. Remove carpet from center and right side of passenger section.
- c. Remove center floorboard panel aft of main spar by removing attaching screws. Handle panel carefully to avoid damaging panel sealing gasket.
- d. Remove second right access floorboard panel aft of main spar by removing attaching screws. Handle panel carefully to avoid damaging panel sealing gasket.
- e. Release elevator cable tension.
- f. Unwrap trim cable from capstan and idler pulleys.
- g. DE-ICER INSTALLED. If the airplane is equipped with de-icers, remove the section of de-icer line, located between the two bulkheads at the trim servo. It is recommended that a protective covering be placed over the open ends of the de-icer line to prevent contamination.
- h. Remove bolts securing trim servo to the mounting bracket.
- i. Disconnect electrical connections from the servo assembly.
- j. Remove trim servo from the airplane.

9-21. INSTALLATION OF TRIM SERVO. (PA-31P.) (Refer to Figure 9-8.)

- a. Position trim servo on the mounting brackets.
- b. Secure trim servo to the mounting brackets with appropriate bolts.
- c. Route the trim cable from the forward part of the airplane around the top capstan groove and around the forward idler pulley, continuing around the aft idler pulley then around the bottom capstan groove to the aft section of the airplane.
- d. Tighten the trim cable to obtain appropriate tension as listed in Table IX-I.
- e. Connect electrical connections to trim servo assembly and check servo operation.
- f. If airplane is equipped with de-icers, install section of de-icer line previously removed.
- g. Ascertain that floorboard panel sealing gaskets are clean and undamaged prior to installation of panels.
- h. Install second right access floorboard panel and center floorboard panel aft of main spar and secure with appropriate screws. Tighten all screws evenly around panels to prevent cabin pressure leaks.
- i. Install carpet and seats previously removed in passenger section.

9-22. REMOVAL OF TRIM AMPLIFIER. (PA-31P.) The trim amplifier is located between sta. 174 and sta. 181 beneath the center floorboard panel aft of the main spar attached to the bulkhead at sta. 181.

- a. Remove passenger seats on right side of airplane.
- b. Remove carpet from center of passenger section.
- c. Remove center floorboard panel aft of main spar by removing attaching screws. Handle panel carefully to avoid damaging panel sealing gasket.
- d. Disconnect CD-41 and CD-45 electrical connections from the trim amplifier.
- e. Disconnect CD-73 electrical connection from the trim servo.
- f. Remove the two mounting screws securing the trim amplifier to the bulkhead.
- g. Remove the trim amplifier from the airplane.

9-23. INSTALLATION OF TRIM AMPLIFIER. (PA-31P.) (Refer to Figure 9-9.)

- a. Position the trim amplifier on the bulkhead and secure with attaching screws.
- b. Connect the CD-41 and CD-45 electrical connections to the trim amplifier.
- c. Connect the CD-73 electrical connection to the trim servo and check servo operation.
- d. Ascertain that floorboard panel sealing gasket is clean and undamaged prior to installation of panel.
- e. Install center floorboard panel aft of main spar and secure with attaching screws. Tighten all screws evenly around panel to prevent cabin pressure leaks.
- f. Install carpet and seats previously removed in passenger section.

9-24. REMOVAL OF TRIM SENSOR. (PA-31P.) The trim sensor is located beneath the center access plate in the floor of the rear baggage area.

NOTE

Depending on the type of interior finish found in PA-31P airplane being serviced, the seat, refreshment bar, or both installed in the airplane between sta. 249.38 and sta. 261.38 must be removed. The carpet can then be removed to permit removal of the access plate covering the trim sensor. Access to the sensor can be gained by the following instructions.

- a. Enter the main entrance door and remove the carpet from the rear baggage area.
- b. Remove the attaching screws from the center access plate in the floor of the rear baggage area and remove access plate. Handle plate carefully to avoid damaging panel sealing gasket.
- c. Cables on the sensor can be removed by applying pressure to both cables and moving the cables out of the trim sensor pulley grooves. If desired, the stabilator cable may be loosened to facilitate removing from the sensor.
- d. Disconnect the CD-41 electrical connection.
- e. Remove the bolts securing the trim sensor to the mounting brackets.
- f. Remove the trim sensor from the airplane.

9-25. INSTALLATION OF TRIM SENSOR. (PA-31P.) (Refer to Figure 9-4.)

- a. With the trim sensor pulleys facing down, route the elevator control cables through the trim sensor pulleys. The trim sensor will center itself on the elevator control cables.
- b. Position the trim sensor on the mounting brackets and secure with appropriate bolts.
- c. Check elevator control cables for proper tension as listed in Table IX-II.

NOTE

The outboard pulleys on the trim sensor must have freedom of rotation and vertical movement from their normal position when the trim sensor is properly aligned with the stabilator cables.

- d. Refer to Paragraph 9-31 for trim sensor centering instructions.
- e. Connect the CD-41 electrical connection and perform ground operational check of the pitch trim system.
- f. Ascertain that access plate sealing gasket is clean and undamaged prior to installation of plate.
- g. Install center access plate and secure with attaching screws. Tighten all screws evenly around access plate to prevent cabin pressure leaks.
- h. Install carpet on floor of rear baggage area and secure.
- i. Install any interior components previously removed.

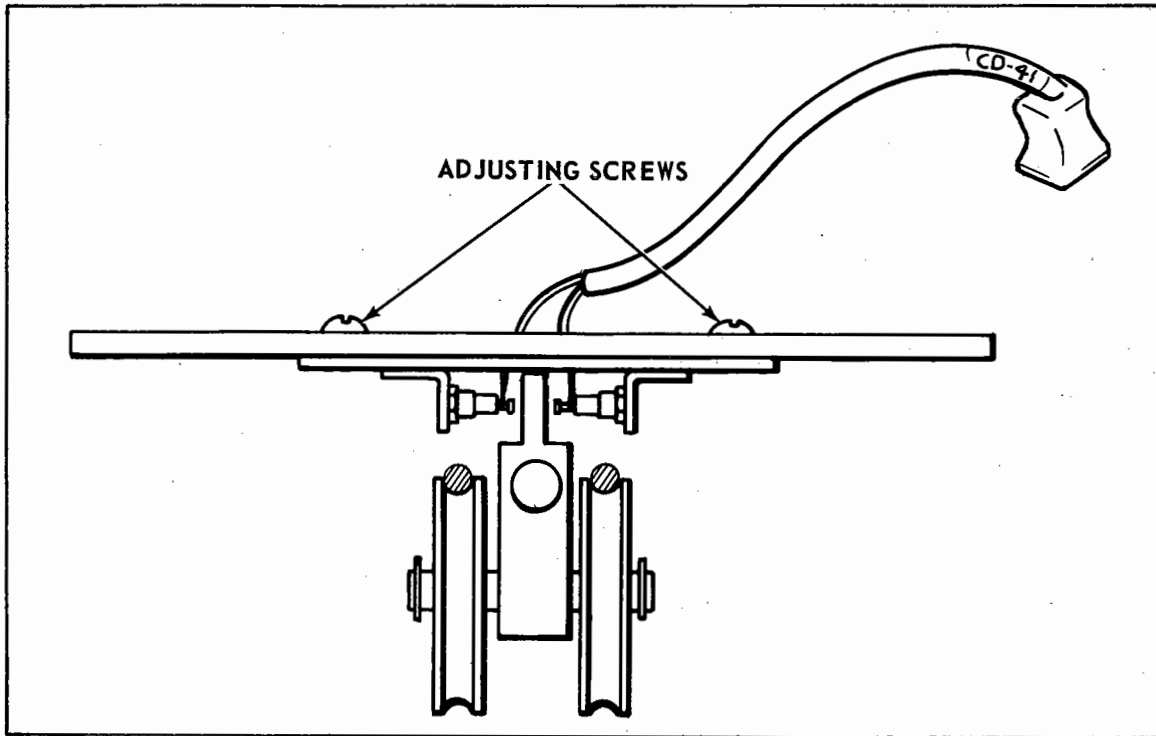

Figure 9-7. PA-31 and PA-31-350 Pendulous Trim Sensor

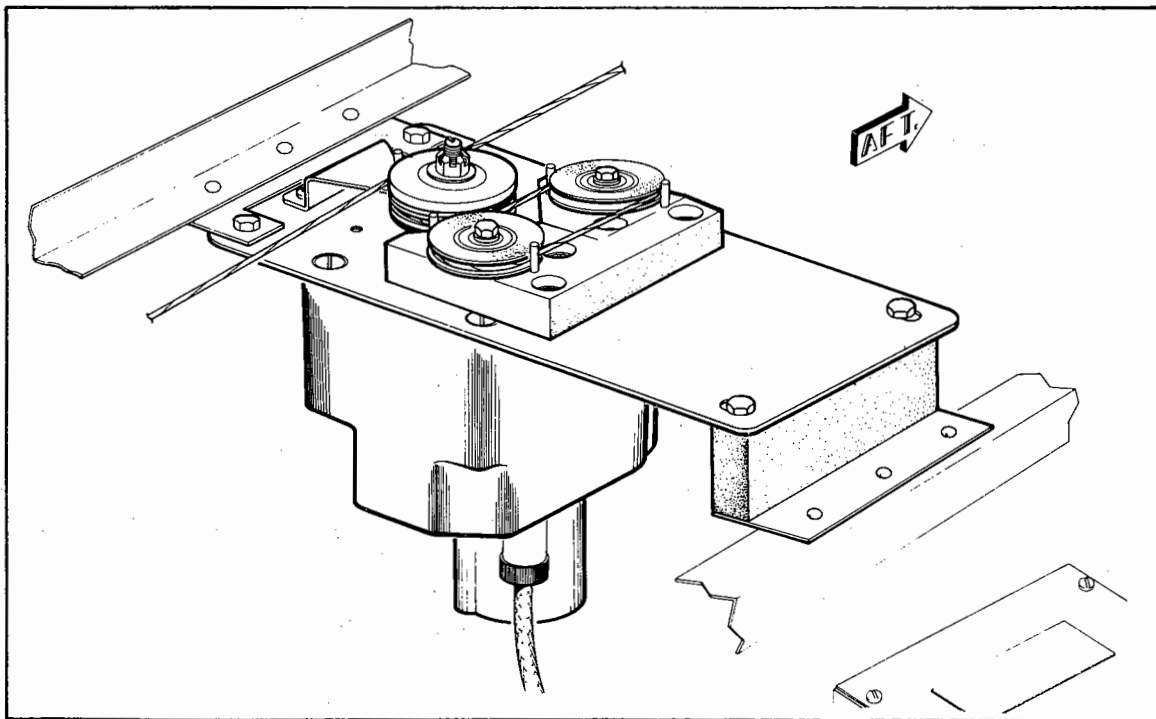

Figure 9-8. PA-31P Trim Servo Cable Routing

9-26. REMOVAL OF TRIM SERVO. (PA-32.) The trim servo is located aft of the baggage compartment. Access to the servo is through the aft baggage compartment.

- a. Remove screws in rear baggage compartment panel and remove panel.
- b. Disconnect electrical connections from the servo assembly.
- c. Remove four mounting bolts securing the servo assembly to the mounting bracket.
- d. Unwrap trim cable from capstan and idler pulleys and remove assembly from the airplane.

9-27. INSTALLATION OF TRIM SERVO. (PA-32.) (Refer to Figure 9-10.)

- a. Position trim servo on mounting brackets and secure with mounting bolts.
- b. Route the trim cable from the forward part of the airplane around the aft idler pulley, then around the top capstan groove and around the aft side of the idler pulley, located approximately in the center of the servo. Form a figure eight by continuing the cable around the bottom capstan groove, then around the forward idler pulley and route trim cable toward the aft section of the airplane.
- c. Tighten the trim cable to obtain appropriate tension as listed in Table IX-I.
- d. Connect electrical connections to trim servo assembly and check servo operation.
- e. Install rear baggage compartment panel and secure with attaching screws.

9-28. REMOVAL OF TRIM SENSOR. (PA-32.) The trim sensor is located under the center tunnel cover attached to the aft section of the rear spar.

NOTE

The PA-32-260 with Serial Numbers 32-451 to 32-1110 inclusive and PA-32-300 with Serial Numbers 32-40000 to 32-40565 are the only PA-32 series airplanes that are equipped with this installation.

- a. Remove the rear seats from the airplane.
- b. The carpet over the center tunnel can be removed by unfastening the snaps at the base of the tunnel cover.

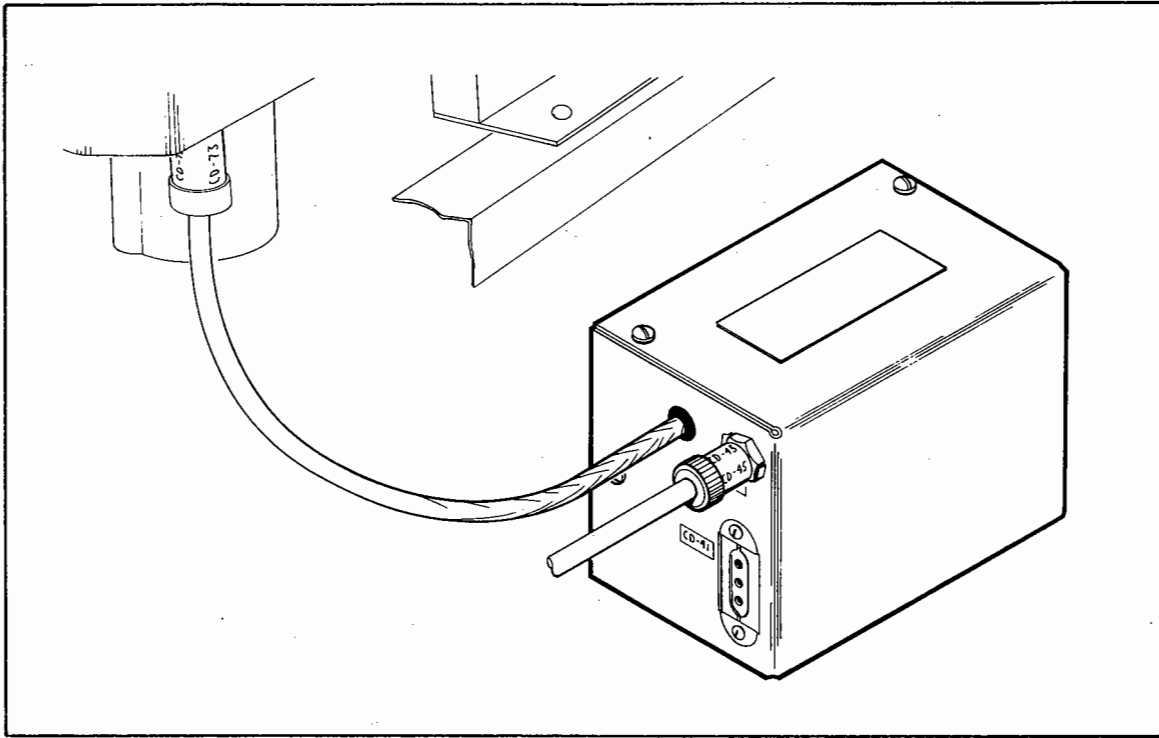

Figure 9-9. PA-31P Trim Servo Amplifier Replacement

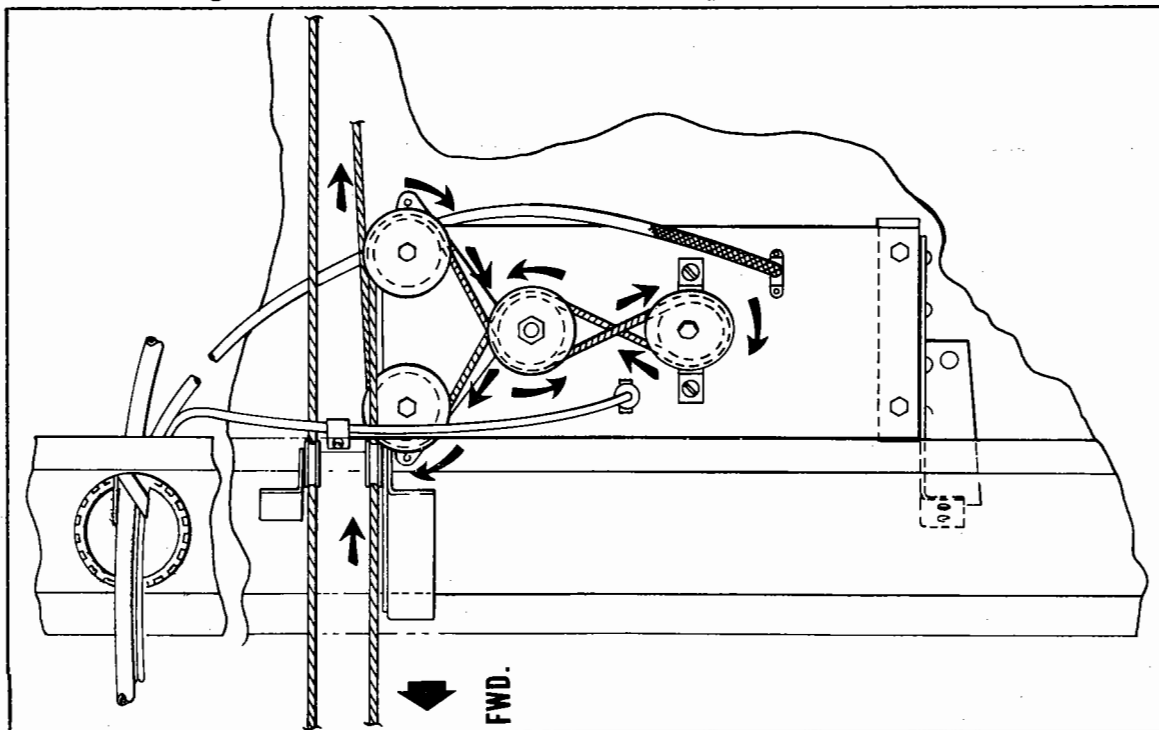

Figure 9-10. PA-32 Trim Servo Cable Routing

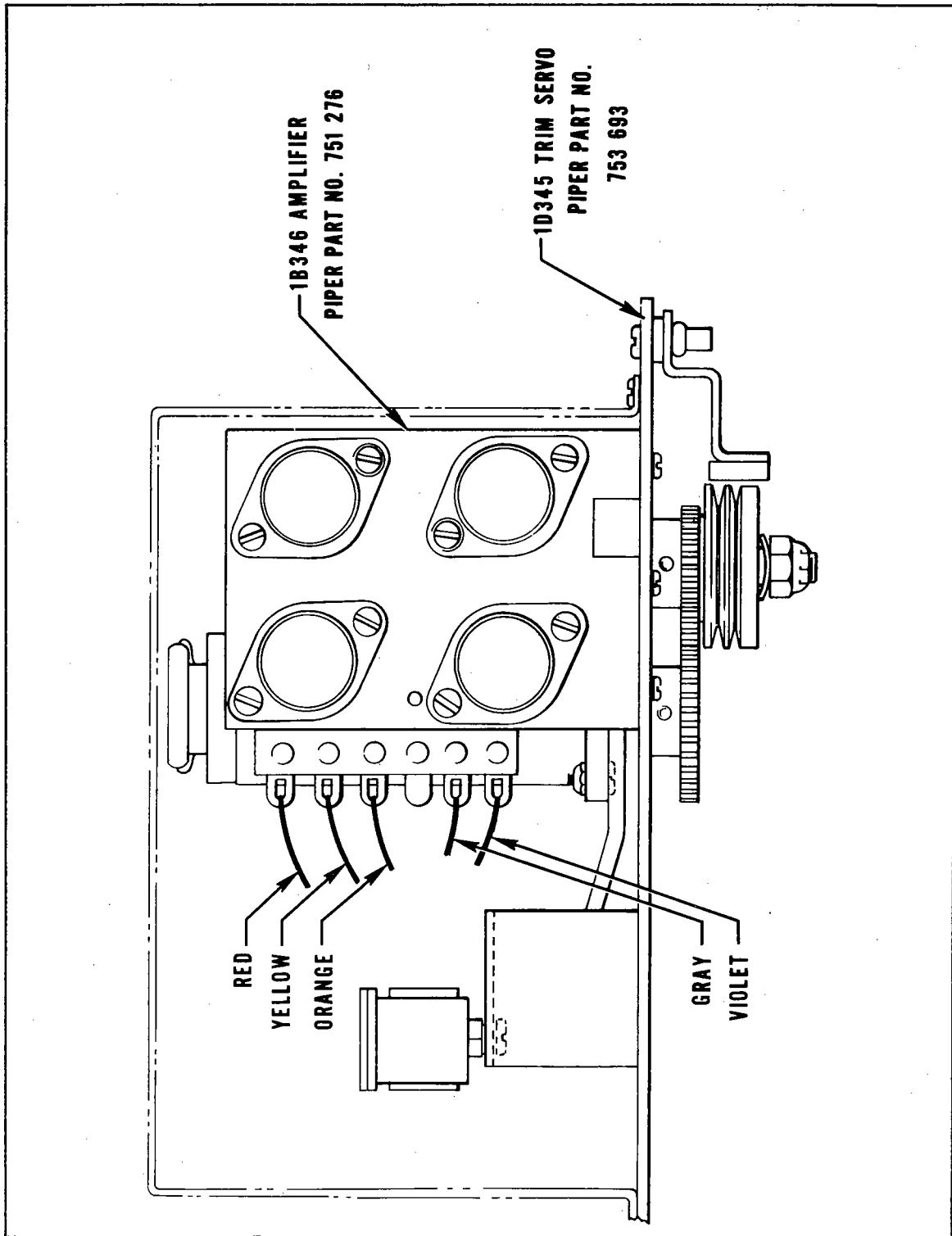

Figure 9-11. Trim Servo Amplifier Replacement (1D345)

- c. Remove the tunnel cover plate by removing the attaching screws.
- d. The cables on the trim sensor can be removed by applying pressure to both cables and moving the cables out of the trim sensor pulley grooves. If desired, the stabilator cable may be loosened to facilitate removing from the sensor.
- e. Disconnect the CD-41 electrical connection.
- f. Loosen nut under trim sensor plate at rear mounting screw and remove rear mounting screw, washer and nut from the trim sensor.
- g. Remove the screws securing the trim sensor to the mounting bracket.
- h. Remove the trim sensor from the airplane.

9-29. INSTALLATION OF TRIM SENSOR. (PA-32.) (Refer to Figure 9-4.)

- a. With the trim sensor pulleys facing down, route the stabilator control cables through the trim sensor pulleys. The trim sensor will center itself on the stabilator control cables.
- b. Position the trim sensor on the forward mounting bracket and secure with appropriate screws.
- c. Install screw, washer and nut in rear mounting hole.
- d. Adjust mounting screw and nut as required to align the trim sensor parallel with the stabilator control cables.
- e. Check stabilator control cables for proper tension as listed in Table IX-II.

NOTE

The outboard pulleys on the trim sensor must have freedom of rotation and vertical movement from their normal position when the trim sensor is properly aligned with the stabilator control cables.

- f. Refer to Paragraph 9-31 for trim sensor centering instructions.
- g. Connect the CD-41 electrical connection and perform the ground operational check for the Pitch Trim System as outlined in Section X, Paragraph 10-6.
- h. Install the tunnel cover plate and secure with attaching screws.
- i. Install carpet and seats previously removed.

9-30. REPLACEMENT OF TRIM AMPLIFIER ON 1D345 TRIM SERVO. (Refer to Figure 9-11.)

NOTE

The 1D345 trim servo must be removed from the airplane when replacing the trim amplifier. Ascertain the type airplane being serviced and refer to the appropriate removal and installation instructions contained in this section of the manual. Replacement trim amplifiers can be ordered under Piper P/N 751 276.

- a. Remove the four screws securing the trim servo cover and remove the cover.
- b. The five wires must be clipped as close to the trim amplifier terminal as possible. The five wires are red, yellow, orange, gray and violet.
- c. Strip insulation from each wire 1/8" and tin each wire.
- d. Remove the three screws securing the trim amplifier to the servo plate and remove amplifier.
- e. Position the replacement amplifier on the servo mounting plate and secure with appropriate screws.
- f. Solder the five wires previously removed to the trim amplifier terminal strip as shown in Figure 9-11. The soldering should be done with a hot iron and quickly so as not to loosen the wires already soldered in the eyelets of the terminal strip.
- g. Install the servo cover and secure with appropriate screws.
- h. Install servo assembly in the airplane as per installation instructions and check the trim system operation.

9-31. TRIM SENSOR CENTERING PROCEDURES. The two types of sensors used on Piper airplanes with the III Series Automatic Pitch Trim Systems are shown in illustration form in this section of the manual, refer to figures 9-12 and 9-13. When making contact centering adjustments, it is very important to ascertain the type of sensor being adjusted and to follow the detailed instructions for that particular type sensor to avoid damage to the test equipment and the sensor.

- a. The following listed test equipment must be used to adjust the trim sensor centering contacts.
 1. Output Meter (66B83-1)
 2. Output Meter Cable (30A177)

3. Output Meter Adapter Cable (66A119)

CAUTION

When using the 66B83-1 Output Meter on Model PA-31 airplanes, it is necessary that an external 12-volt power source be used since the 24-volt system incorporated in the airplane would result in damage to the Output Meter.

- b. Support the stabilator in approximate level flight position before proceeding with trim sensor contact centering procedure, regardless of type of sensor being serviced.

NOTE

The stabilator should be firmly supported at its trailing edge. Place support on stabilator, not on trim tab. Do not attempt to hold the stabilator in position as it is impossible to hand hold the stabilator steady enough to accomplish the correct adjustment. A typical stabilator holding fixture is shown in Figure 9-2. Such a fixture should be used in conjunction with a jack placed under the tail skid.

- c. Centering procedure for Plate Type Trim Sensor. (Refer to Figure 9-12.)
 1. Turn OFF airplane master switch.

CAUTION

Whenever a trim sensor without an amplifier mounted on the sensor is being adjusted by use of the Output Meter, it is necessary to use the 66A119 adapter cable. If the adapter cable is not used, the Output Meter or Cable may be damaged by a direct short. The Output Meter will become warm after a few minutes use due to the internal resistive load of the meter and should in no way be mistaken for a defective meter as this is normal operation.

2. Connect either end of Cable 30A177 to the Output Meter. (The 30A177 Cable is the one with a single wire lead terminating with an alligator clip.)
3. Connect the remaining end of the 30A177 Cable to the female end of the 66A119 adapter cable.
4. Connect the male end of the adapter cable to the CD-41 lead on the trim sensor.
5. Connect the alligator clip of Cable 30A177 to a 12-volt POSITIVE source.
6. Make sure the sensor pulleys are parallel to the stabilator cables and stabilator is blocked to approximately level flight.
7. Turn on 12-volt source.
8. If Output Meter indicates zero output, the contacts are centered, proceed to step d. If not, proceed with the following steps.
 - a. Loosen both screws of the contact support bar. (Refer to Figure 9-12.)
 - b. Rotate eccentric nut on the contact support bar to obtain zero output on the meter.
 - c. Tighten screws on the contact support bar.
 - d. Apply forward pressure on the control wheel, the Output Meter should deflect.
 - e. Release the forward pressure on the control wheel.
 - f. The Output Meter may either center or remain deflected in the same direction.
 - g. Apply aft pressure on the control wheel, the Output Meter should deflect in the opposite direction.
 - h. Release the aft pressure on the control wheel.
 - i. The Output Meter may either center or remain deflected in the same direction.

NOTE

If the Output Meter reverses direction of deflection when the forward or aft pressure on the control wheel is released, the trim sensor centering must be reaccomplished.

- j. Turn off 12-volt source and disconnect Output Meter and associated cables.
- k. Connect CD-41 electrical connection.
- d. Centering procedure for Pendulous Type Trim Sensor. (Refer to Figure 9-13.)
 1. Turn OFF airplane master switch.

CAUTION

Whenever a trim sensor without an amplifier mounted on the sensor itself is being adjusted by the use of the Output Meter, it is necessary to use the 66A119 Adapter Cable. If the adapter cable is not used, the Output Meter or Cable may be damaged by a direct short. The Output Meter will become warm after a few minutes use due to the internal resistive load of the meter, and should in no way be mistaken for a defective meter as this is normal operation.

2. Connect either end of Cable 30A177 to the Output Meter. (The 30A177 Cable is the one with a single wire lead terminating with an alligator clip.)
3. Connect the remaining end of the 30A177 Cable to the female end of the 66A119 adapter cable.
4. Connect the male end of the adapter cable to the CD-41 lead on the trim sensor.
5. Connect the alligator clip of Cable 30A177 to a 12-volt POSITIVE source.
6. Stabilator to be blocked to approximate level flight.
7. Turn on 12-volt source.
8. If Output Meter indicates zero output, the contacts are centered, proceed to Step e. If not, proceed with the following steps.
 - a. Carefully loosen the two adjusting screws to permit the contact adjustment bracket to move with some friction. (Refer to Figure 9-13.)
 - b. Grasp both stabilator cables, evenly pull upward, then release them.
 - c. When the Output Meter is centered, carefully tighten the adjusting screws. Tighten each adjusting screw a slight amount then proceed to the other screw. Repeat this sequence until both screws are tight.
 - d. The Output Meter should read zero. If zero output is not obtained, repeat steps a thru c.
 - e. Apply forward pressure on the control wheel, the Output Meter should deflect.
 - f. Release the forward pressure on the control wheel.
 - g. The Output Meter may either center or remain deflected in the same direction.

- h. Apply aft pressure on the control wheel, the Output Meter should deflect in the opposite direction.
- i. Release the aft pressure on the control wheel.
- j. The Output Meter may either center or remain deflected in the same direction.

NOTE

If the Output Meter reverses direction of deflection when the forward or aft pressure on the control wheel is released, the trim sensor centering must be reaccomplished.

- k. Turn off 12-volt source and disconnect Output Meter and associated cables.
- l. Connect CD-41 electrical connector.

9-32. REMOVAL OF TRIM WARNING SYSTEM. The Trim Warning System is located on a mounting bracket near the trim servo on all Piper airplanes.

NOTE

Prior to removal of the Trim Warning System, ascertain the type airplane being serviced. Locate and utilize the appropriate trim servo removal instructions in this section of the manual to gain access to the Trim Warning System and proceed with the following instructions.

- a. Gain access to the Trim Warning System as per trim servo removal instructions.
- b. Disconnect the CD-86 and CD-87 electrical connections from the Trim Warning System.
- c. Remove the screws securing the Trim Warning System to the mounting bracket.
- d. Remove the Trim Warning System from the airplane.

9-33. INSTALLATION OF TRIM WARNING SYSTEM. (Refer to Figure 9-11a.)

- a. Position the Trim Warning System on the mounting bracket and secure with appropriate screws.
- b. Connect the CD-86 and CD-87 electrical connections to the Trim Warning System.
- c. Check operation of Trim Warning System.
- d. Utilize the appropriate Trim Servo installation instructions to facilitate reinstallation of all panels and components previously removed from the airplane.

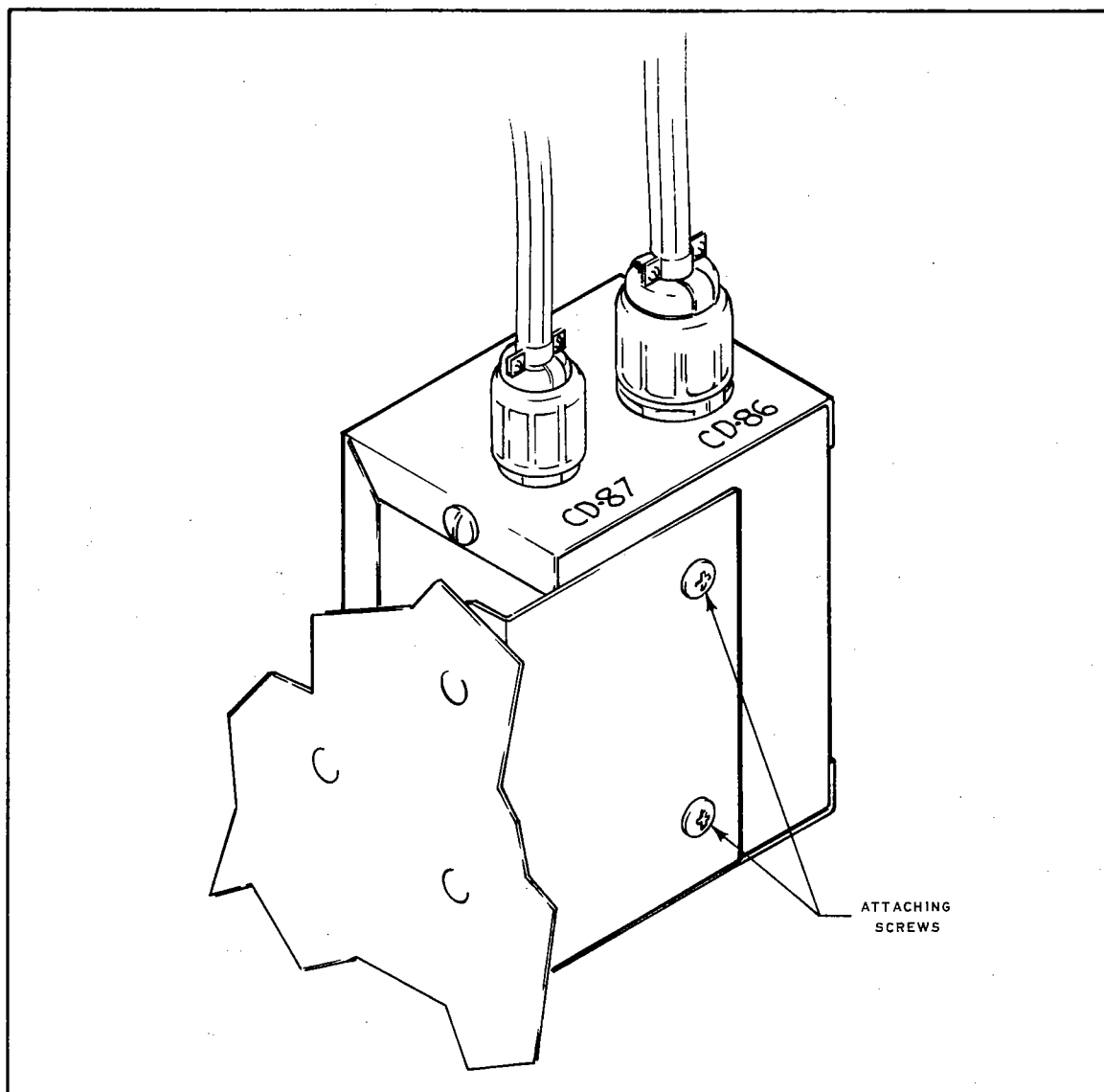

Figure 9-11a. PA-23-250, PA-24, PA-30, PA-31, PA-31-350, PA-31P and PA-39 Trim Warning System

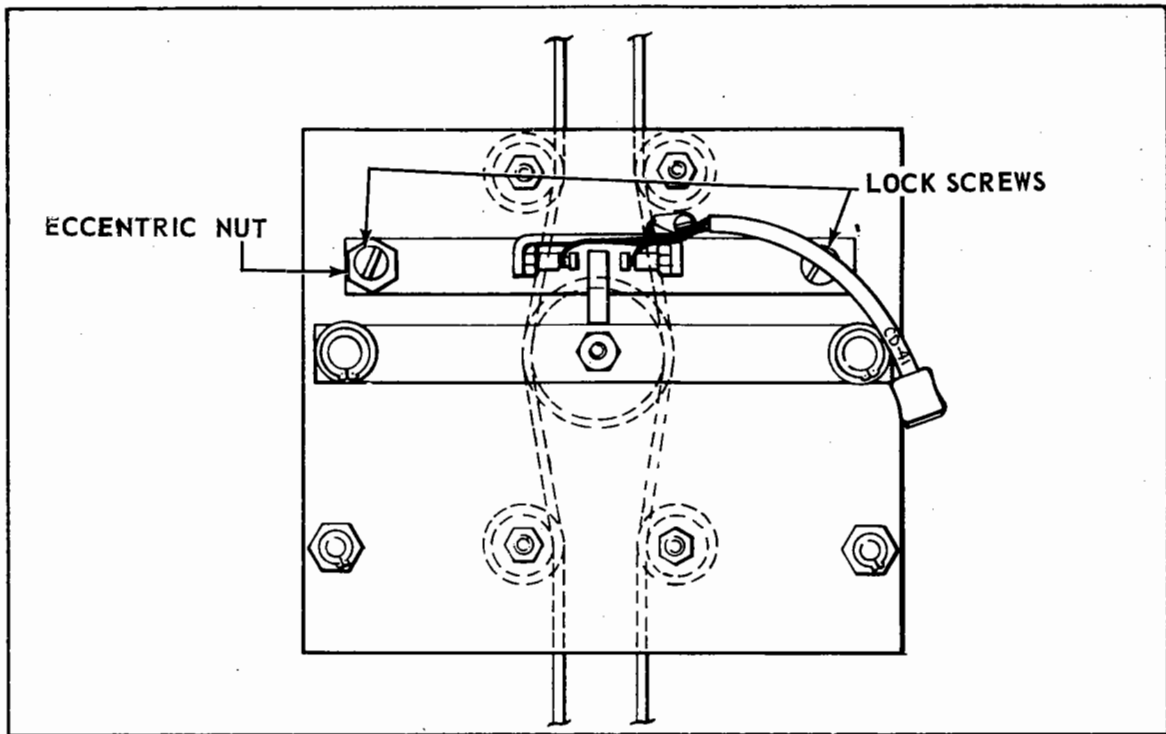

Figure 9-12. Plate Sensor Without Amplifier

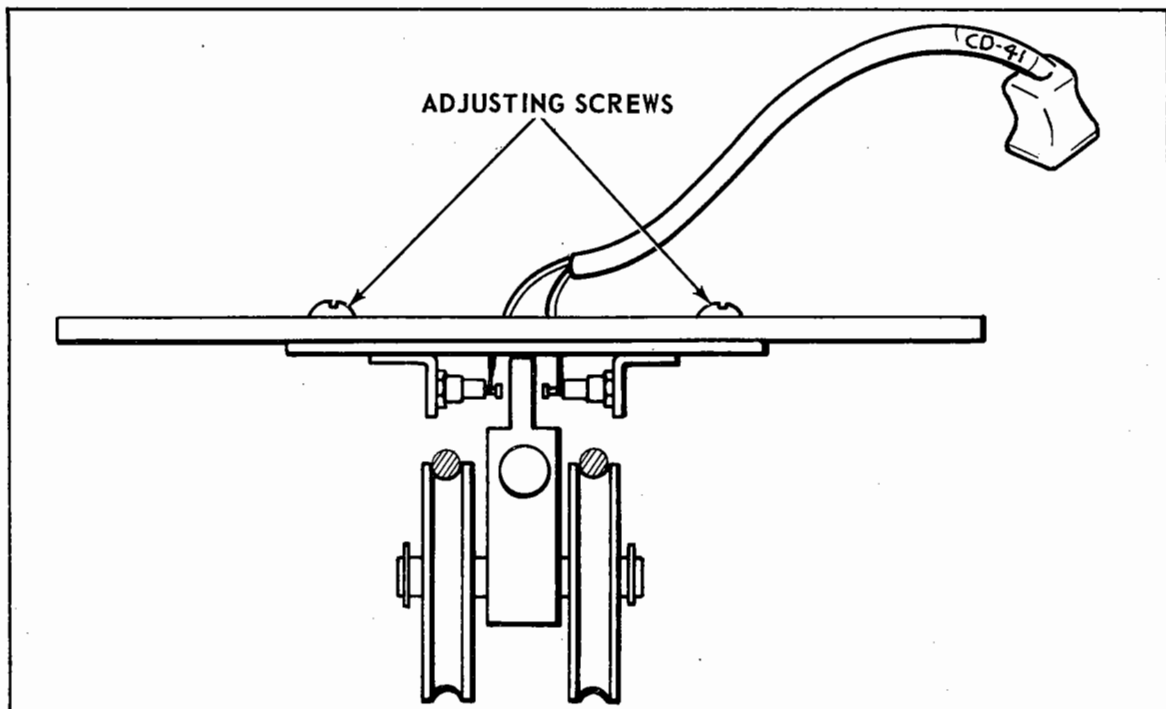

Figure 9-13. Pendulous Sensor Without Amplifier

TABLE IX-I. TRIM SERVO CABLE TENSION

AIRPLANE	CABLE	CABLE TENSION
PA-23-250	Stabilator Trim	15 lbs. \pm 20% (3 lbs.)
PA-24	Stabilator Trim	12 lbs. \pm 20% (2.4 lbs.)
PA-30	Stabilator Trim	12 lbs. \pm 20% (2.4 lbs.)
PA-31 & PA-31-350	Elevator Trim	14 lbs. \pm 2 lbs.
PA-31P	Elevator Trim	14 lbs. \pm 2 lbs.
PA-32	Stabilator Trim	10 lbs. \pm 1 lb.
PA-34-200	Stabilator Trim	10 lbs. \pm 2 lbs.
PA-39	Stabilator Trim	12 lbs. \pm 20% (2.4 lbs.)

TABLE IX-II. TRIM SENSOR CABLE TENSION

AIRPLANE	CABLE	CABLE TENSION
PA-23-250	Stabilator	35 lbs. \pm 10% (3.5 lbs.)
PA-24	Stabilator	18 lbs. \pm 20% (3.6 lbs.)
PA-30	Stabilator	18 lbs. \pm 20% (3.6 lbs.)
PA-31 & PA-31-350	Elevator	20 lbs. \pm 2 lbs.
PA-31P	Elevator	20 lbs. \pm 2 lbs.
PA-32	Stabilator	40 lbs. \pm 5 lbs.
PA-34-200	Stabilator	40 lbs. \pm 5-0 lbs.
PA-39	Stabilator	18 lbs. \pm 20% (3.6 lbs.)

9-34. REMOVAL OF TRIM SERVO. (PA-34-200.) The trim servo is located aft of the rear baggage area on the lower fuselage.

- a. Access to the servo is through the rear baggage area.
- b. Remove the access plate in lower right side of aft panel in rear baggage area by turning the screw type fasteners to release the panel.
- c. Loosen trim cable turnbuckles to release cable tension.
- d. Disconnect electrical connections from the servo assembly.
- e. Remove four bolts securing the servo assembly to the mounting brackets.
- f. Unwrap the trim cable from capstan and idler pulleys and remove servo assembly from the airplane.

9-35. INSTALLATION OF TRIM SERVO. (PA-34-200.) (Refer to Figure 9-14.)

- a. Position the trim servo on the mounting bracket and secure with appropriate nuts and bolts.
- b. Route the trim cable from the forward part of the airplane around the aft inboard idler pulley, then around the bottom capstan groove and around the aft outboard idler pulley continuing around the forward outboard idler pulley and around the top capstan groove to the forward inboard idler pulley, to the aft section of the airplane.
- c. Tighten the trim cable to obtain the appropriate tension as listed in Table IX-I.
- d. Connect electrical connections to the trim servo assembly and check servo operation.
- e. Install access plate in lower right side of aft panel in rear baggage area and turn screw type fasteners to secure access plate.

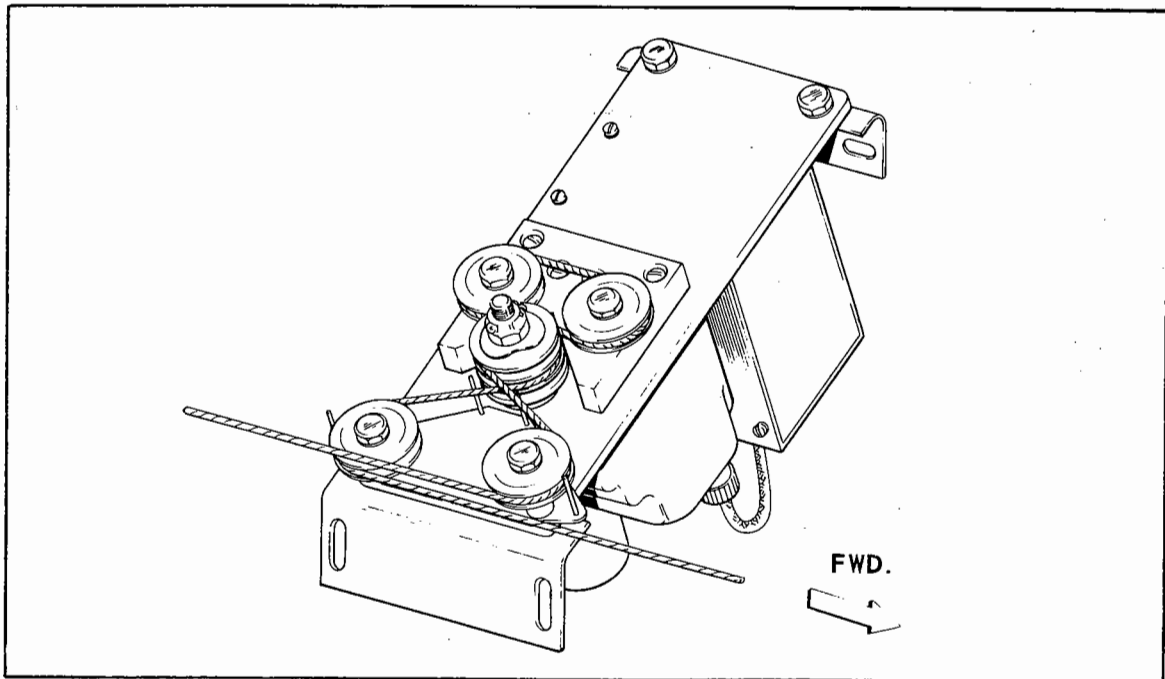

Figure 9-14. PA-34-200 Trim Servo Cable Routing

9-36. REMOVAL OF TRIM AMPLIFIER. (PA-34-200.) The trim amplifier is located on the trim servo mounting plate aft of the rear baggage area on the lower fuselage.

- a. Access to the amplifier is through the rear baggage area.
- b. Remove the access plate in lower right side of aft panel in rear baggage area by turning the screw type fasteners to release the panel.
- c. Disconnect CD-41 and CD-45 electrical connections from the trim amplifier.
- d. Disconnect CD-73 electrical connection from trim servo.
- e. Remove the two screws securing the trim amplifier to the trim servo mounting plate.
- f. Remove the trim amplifier from the airplane.

9-37. INSTALLATION OF TRIM AMPLIFIER. (PA-34-200.) (Refer to Figure 9-14.)

- a. Position the trim amplifier on the trim servo mounting plate and secure with appropriate screws.
- b. Connect CD-41 and CD-45 electrical connections to the trim amplifier.
- c. Connect CD-73 electrical connection to the trim servo and check servo operation.
- d. Install access plate in lower right side of aft panel in rear baggage area and turn screw type fasteners to secure access plate.

9-38. REMOVAL OF TRIM SENSOR. (PA-34-200.) The trim sensor is located under the center tunnel cover attached to the aft section of the rear spar.

- a. Remove the rear seats from the airplane.
- b. The carpet over the center tunnel can be removed by unfastening the snaps at the base of the tunnel cover.
- c. Remove the tunnel cover plate by removing the attaching screws.
- d. The cables on the trim sensor can be removed by applying pressure to both cables and moving the cables out of the trim sensor pulley grooves. If desired, the stabilator cable may be loosened to facilitate removing from the sensor.
- e. Disconnect the CD-41 electrical connection from the trim sensor.
- f. Remove the three nuts and bolts securing the trim sensor to the mounting brackets and remove the sensor from the airplane.

9-39. INSTALLATION OF TRIM SENSOR. (PA-34-200.) (Refer to Figure 9-4.)

- a. With the trim sensor pulleys facing down, route the stabilator control cables through the trim sensor pulleys. The trim sensor will center itself on the stabilator control cables.
- b. Position the trim sensor on the mounting brackets (adjust height of trim sensor as required with #AN960-10 and #AN960-10L washers) and secure with appropriate nuts and bolts.
- c. Check stabilator control cables for proper tension as listed in Table IX-II.

NOTE

The outboard pulleys on the trim sensor must have freedom of rotation and vertical movement from their normal position when the trim sensor is properly aligned with the stabilator control cables.

- d. Refer to Paragraph 9-31 for trim sensor centering instructions.
- e. Connect the CD-41 electrical connection and perform the ground operational check for the pitch trim system as outlined in Section X, Paragraph 10-6.
- f. Install tunnel cover plate and secure with attaching screws.
- g. Install carpet and seats previously removed.

SECTION X

ADJUSTMENT PROCEDURES AND OPERATIONAL CHECKS

Paragraph		Page
10-1.	Description	10-1
10-2.	Control Wheel Harness Connections	10-1
10-3.	III Series Trim Servo Clutch Adjustment Procedure	10-1
10-4.	III Series Trim Servo Engage Solenoid Adjustment for 1D345 and 1C463 Servos Only	10-2
10-5.	Adjustment of Pitch Servo Selector Switch and Pitch AutoPilot Servo Motor Switch	10-5
10-6.	Ground Checks for III Series Automatic Electric Pitch Trim System	10-6
10-7.	Testing the III Series Automatic Pitch Trim Warning System	10-13
10-8.	Testing the Automatic Mode of the III Series Automatic Pitch Trim System using the Trim Servo Test Plug - Piper P/N 757 299	10-13
10-9.	Flight Checks of the III Series Automatic Electric Pitch Trim System	10-14

SECTION X

ADJUSTMENT PROCEDURE AND OPERATIONAL CHECKS

10-1. DESCRIPTION. This section provides the information necessary to properly adjust and perform operational checks of the III Series Electric Pitch Trim Systems. The first part of this section is comprised of servo adjustments and wiring connections for the control wheel trim switch. The second part consists of operational checks of the III Series Electric Pitch Trim System.

Complete trim sensor contact adjustment procedures are described in Section IX, Removal and Installation. Information pertaining to trim sensor adjustment can be obtained by referring to the particular type sensor installation.

10-2. CONTROL WHEEL HARNESS CONNECTIONS. The pitch trim switch is mounted in the control wheel and is electrically connected to the components of the trim system through a coiled harness assembly. The connections for each different installation are shown in illustration form in this section. When replacing a defective switch, refer to Figures 10-4 thru 10-16 inclusive for the proper wiring connections to be made on the airplane being serviced.

10-3. III SERIES TRIM SERVO CLUTCH ADJUSTMENT PROCEDURE.

NOTE

This adjustment procedure requires two service men.

- a. Attach a 0-50 lb. spring scale to the trim tab cable which is attached to the trim servo. (Refer to Figure 10-1.)
- b. Turn the airplane master switch on.
- c. Using pilot's trim switch, actuate trim system in direction away from scale.
- d. Hold scale steady and note reading at which clutch slips. Clutch tolerance is listed in Table X-I for each type airplane.
- e. To adjust clutch, refer to Figure 10-2 and proceed as follows:
 1. Remove the cotter pin from the clutch tension nut.

2. Rotate the clutch tension nut item #8 in the desired direction to obtain specified setting.

NOTE

Clockwise rotation of the nut increases clutch tension. Counterclockwise rotation of the nut decreases clutch tension. There are two holes drilled through the capstan shaft. One-half castellation movement of the nut will change the tension approximately five pounds.

10-4. III SERIES TRIM SERVO ENGAGE SOLENOID ADJUSTMENT FOR 1D345 AND 1C463 SERVOS ONLY. (Refer to Figure 10-2.)

NOTE

The trim servo must be removed from the airplane when making the engage solenoid adjustment. Ascertain the type airplane being serviced and refer to the appropriate removal and installation instructions contained in Section IX of this manual. The engagement solenoid adjustment is a mechanical adjustment and no special tools or fixtures are required.

- a. Remove servo cover item #1.
- b. Remove solenoid screws item #2 and lockwashers item #3.
- c. Remove lockwashers from screws and reinstall screws. Do not tighten.
- d. Using a small screwdriver, apply pressure directly on the end of the solenoid plunger item #4 until gears item #5 and item #6 are fully meshed.
- e. Position solenoid item #7 so that solenoid plunger lacks approximately 1/64" bottoming in solenoid.
- f. Tighten mounting screws item #2.
- g. Apply additional pressure to solenoid plunger. This should result in bottoming of plunger if solenoid is correctly positioned.
- h. Remove mounting screws item #2, ONE AT A TIME, and reinstall with lockwashers item #3 in place.
- i. Tighten mounting screws securely.
- j. Reinstall servo cover.

TABLE X-I. III SERIES TRIM SERVO CLUTCH TENSION

AIRPLANE	SERVO NO.	CLUTCH SETTING
PA-23	1D345	25 ± 5 lbs.
	1C345-1	25 ± 5 lbs.
PA-24	1D345	25 ± 5 lbs.
	1D345-1	25 ± 5 lbs.
PA-30	1D345	25 ± 5 lbs.
	1C345-1	25 ± 5 lbs.
PA-31	1C463	20 ± 5 lbs.
PA-31	1C463-1	20 ± 5 lbs.
PA-31-350	1C463-1	25 ± 3 lbs.
PA-31P	1C463-1	35 ± 5 lbs.
PA-32	1D345	25 ± 5 lbs.
PA-34-200	1C345-1	20 ± 5 lbs.
PA-39	1C345-1	20 ± 5 lbs.

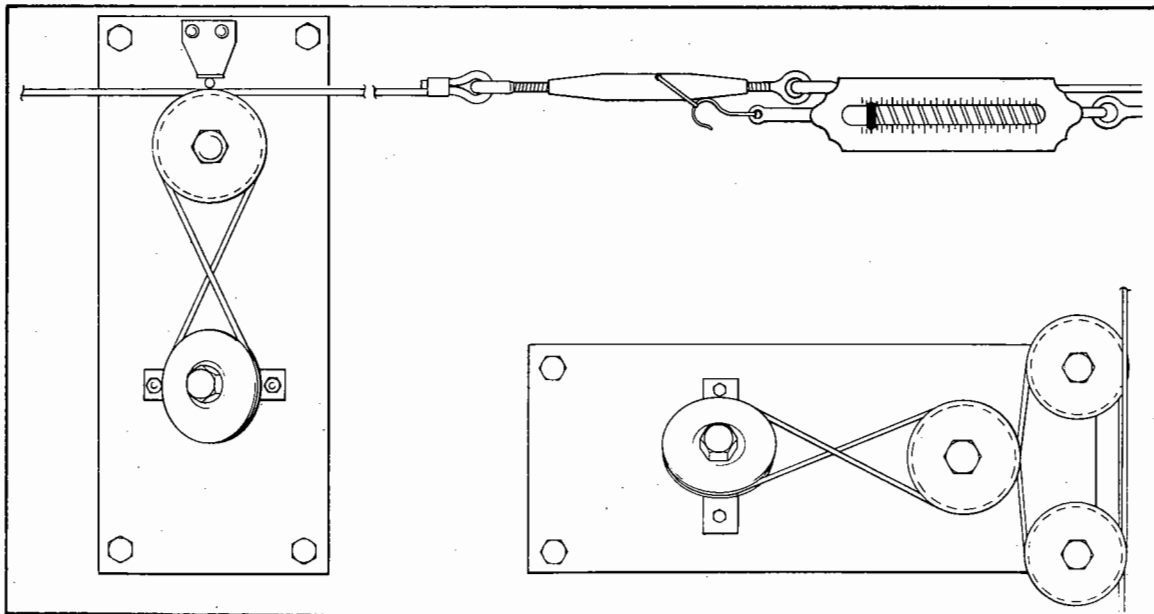

Figure 10-1. III Series Trim Servo Clutch Adjustment

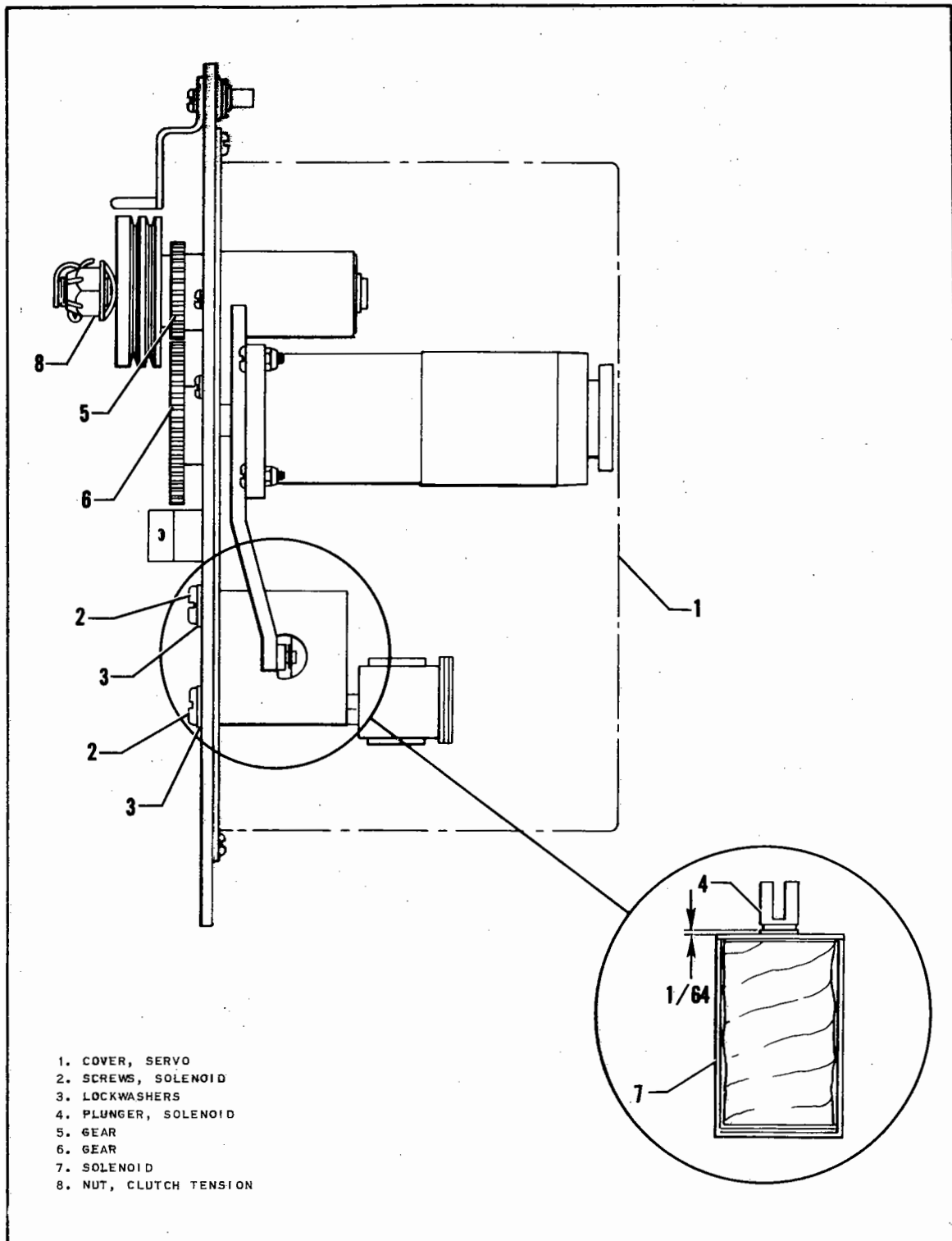

Figure 10-2. Clutch and Clutch Solenoid Coil Adjusting Details

10-5. ADJUSTMENT OF PITCH SERVO SELECTOR SWITCH AND PITCH AUTOPILOT SERVO MOTOR SWITCH. (Refer to Figure 10-3.)

This adjustment procedure is for AltiMatic II installation containing the Rack and Pinion type servo. The cams used for adjustment of the switches are double stacked on the same retaining screw. The top cam adjustment is for the servo selector switch and the bottom cam adjustment is for the pitch servo motor switch. The following detailed adjusting procedures will explain the adjusting details for both switches. The switches are actuated by the AltiMatic II pitch engage knob position. The cams must be adjusted so the top switch (servo selector switch) actuates when the AltiMatic II pitch engage knob is rotated through the 11:00 o'clock position and the bottom switch (AutoPilot servo motor switch) actuates when the AltiMatic II pitch engage knob is rotated through the 1:00 o'clock position. In addition, the bottom switch must actuate before the AutoPilot servo motor gears begin to mesh and both switches must deactuate before the AltiMatic II pitch engage knob is rotated to its OFF position.

NOTE

The adjustment of these switches must be accomplished in the airplane. The switch adjustment procedure can be accomplished in the PA-23 airplanes without removing the AltiMatic II Pitch Servo. In the PA-24 and PA-30 airplanes the AltiMatic II Pitch Servo must be removed to adjust these switches. Do not disconnect the servo engage flex cable. Refer to the I and II Series AutoPilot Service Manual Piper P/N 753 798 for AltiMatic II Pitch Servo removal and installation instructions.

- a. Switch Adjustment Procedure. (Refer to Figure 10-3.)
 1. Loosen cam screw slightly.

NOTE

If the cam screw is loosened excessively cam adjustment will be more difficult. Use extreme caution when adjusting the cams to prevent damage to the follow-up condenser plates and switch springs.

2. Position the bottom cam so the bottom switch actuates when the AltiMatic II pitch engage knob is at the 1:00 o'clock position.
3. Hold the bottom cam in position and tighten the cam screw.
4. Rotate the AltiMatic II pitch engage knob through the 1:00 o'clock position and ascertain that the bottom switch actuates. If the switch fails to actuate at the 1:00 o'clock position repeat steps 1 thru 3 until the bottom switch is actuated when the pitch AutoPilot knob is rotated through the 1:00 o'clock position.
5. Hold the bottom cam in position and loosen the cam screw slightly.
6. Position the top cam until the top switch actuates when the AltiMatic II pitch engage knob is at the 11:00 o'clock position.

PIPER PITCH TRIM SERVICE MANUAL

7. Hold both cams in position and tighten the cam screw.
8. Ascertain that the top switch actuates when the AltiMatic II pitch engage knob is rotated to the 11:00 o'clock position and the bottom switch actuates when the AltiMatic II pitch engage knob is rotated to the 1:00 o'clock position. The bottom switch should actuate before the pitch servo gears start to engage and both switches should deactivate before the pitch engage knob is returned to its OFF position.

10-6. GROUND CHECKS FOR III SERIES AUTOMATIC ELECTRIC PITCH TRIM SYSTEM. This section contains the information necessary to ground check the operation of the III Series Electric Pitch Trim Systems used in Piper airplanes. The following listed checks are accomplished with the airplane master switch and the trim circuit breaker in the ON position. Also the panel mounted and/or control wheel mounted trim quick disconnect switch, when installed, must be pushed to the ON position. Schematics for electrical circuits of the III Series Electric Pitch Trim Systems are located in Section XII of this manual.

NOTE

In the event the trim servo does not drive the pitch trim system, it must be determined if the malfunction is mechanical or electrical. If mechanical malfunction, refer to Clutch Adjustment Procedure, Paragraph 10-3. If electrical, refer to Section XII and utilize the appropriate schematic to troubleshoot the trim system.

- a. III SERIES AUTOMATIC ELECTRIC PITCH TRIM SYSTEM - MANUAL MODE.
 1. Place the pitch trim at approximately neutral position.
 2. Place the AltiMatic II pitch engage knob at the OFF position or push the AltiMatic III Series ROLL and PITCH switches to the OFF position.
 3. Push the trim switch on the pilot's control wheel (on PA-31-350 and PA-34-200 airplanes the disengage button must be depressed, also the panel mounted and/or control wheel mounted trim quick disconnect switch must be pushed to the ON position) to the NOSE DOWN position. The trim servo should drive the pitch trim NOSE DOWN.
 4. Push the trim switch on the pilot's control wheel (on PA-31-350 and PA-34-200 airplanes the disengage button must be depressed, also the panel mounted and/or control wheel mounted trim quick disconnect switch must be pushed to the ON position) to the NOSE UP position. The trim servo should drive the pitch trim NOSE UP.
 5. (PA-31-350 and PA-34-200 Only.) With trim in motion push the panel mounted or control wheel mounted trim quick disconnect switch to the OFF position. All trim action should stop.
 6. (PA-31-350 and PA-34-200 Only.) With the trim switch in the center or OFF position press the disengage button mounted in the trim switch. Trim should not operate. Release disengage button and push the trim switch both fore and aft, trim should not operate.
 7. With the trim switch in the center or OFF position, apply FORE and AFT pressure on the control wheel. The trim servo should not drive the pitch trim.

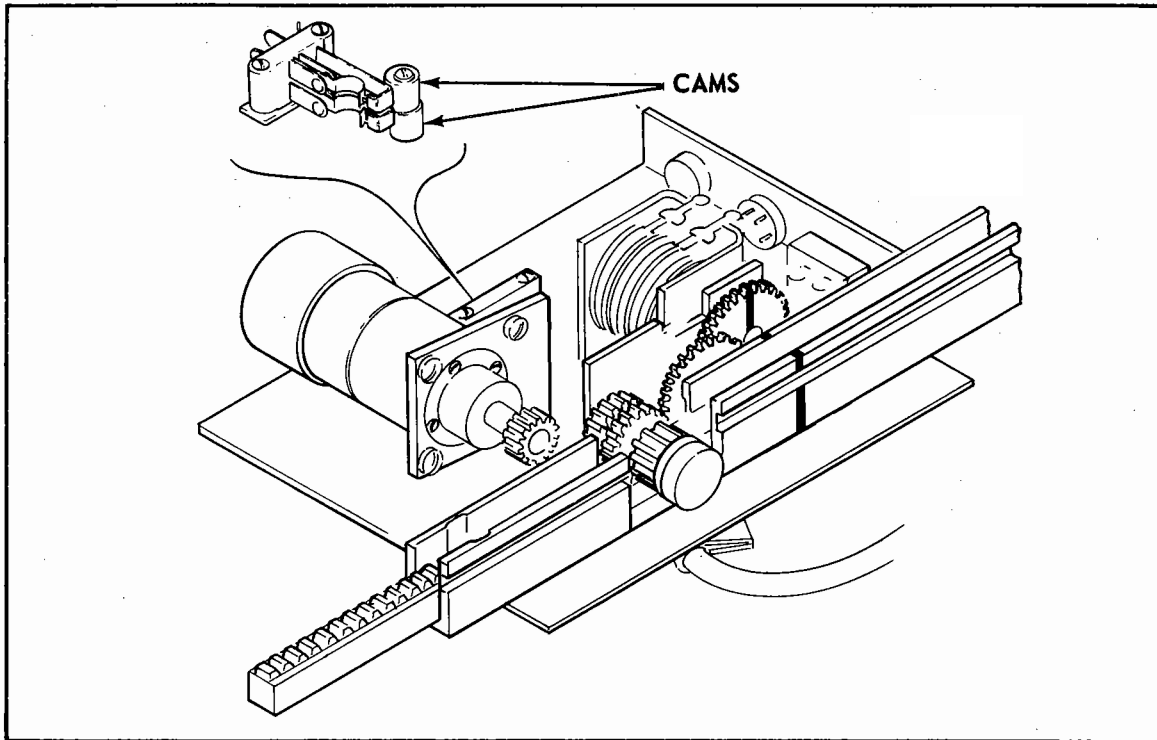

Figure 10-3. Switch Adjustment Cams

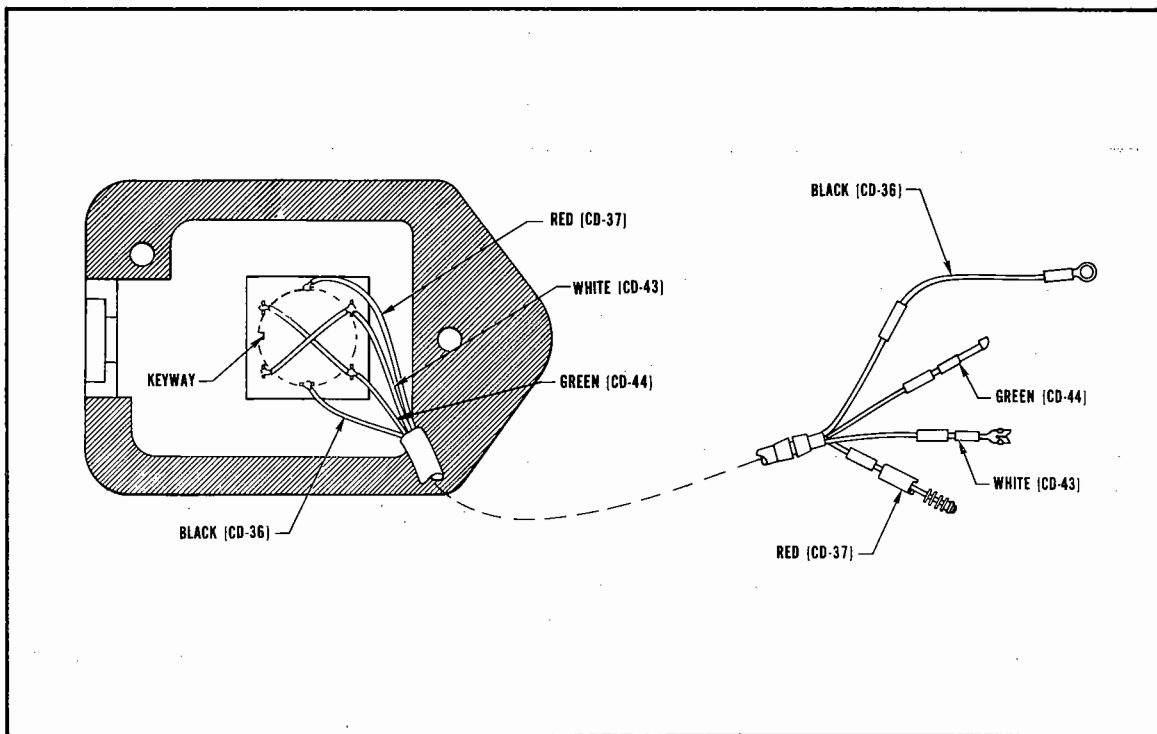

Figure 10-4. PA-23-250, PA-24 and PA-30 AltiMatic II

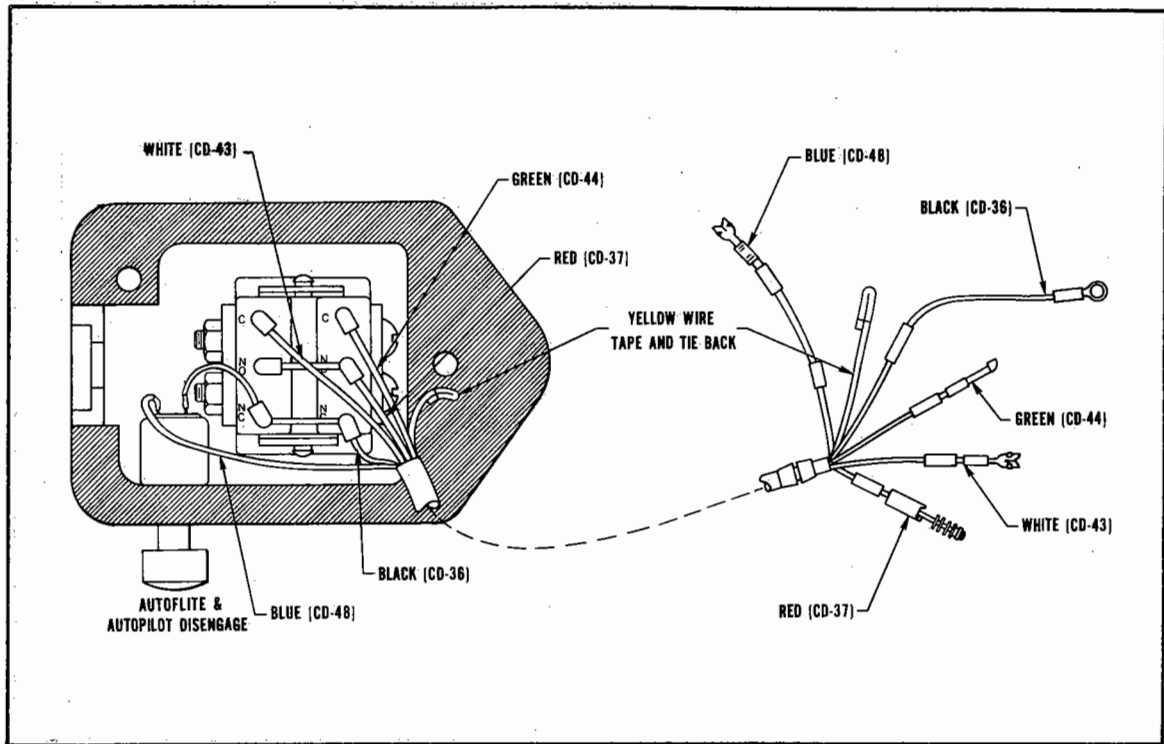

Figure 10-5. PA-23-250 AltiMatic III

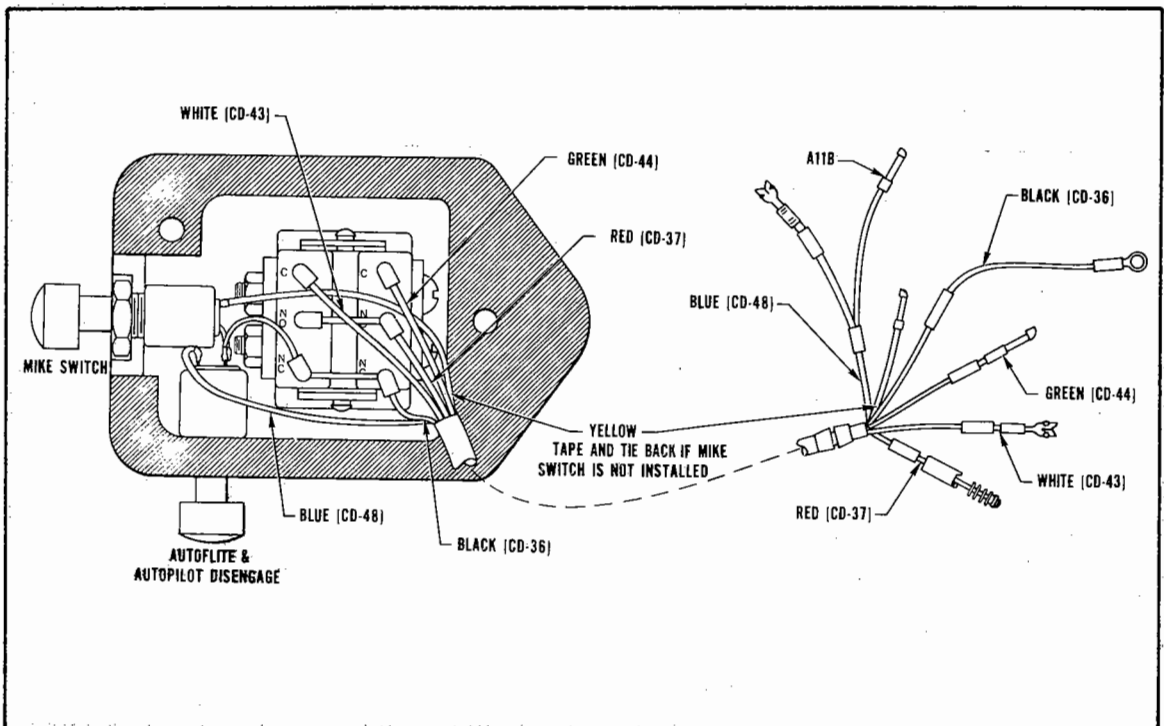

Figure 10-6. PA-23-250 AltiMatic IIIB

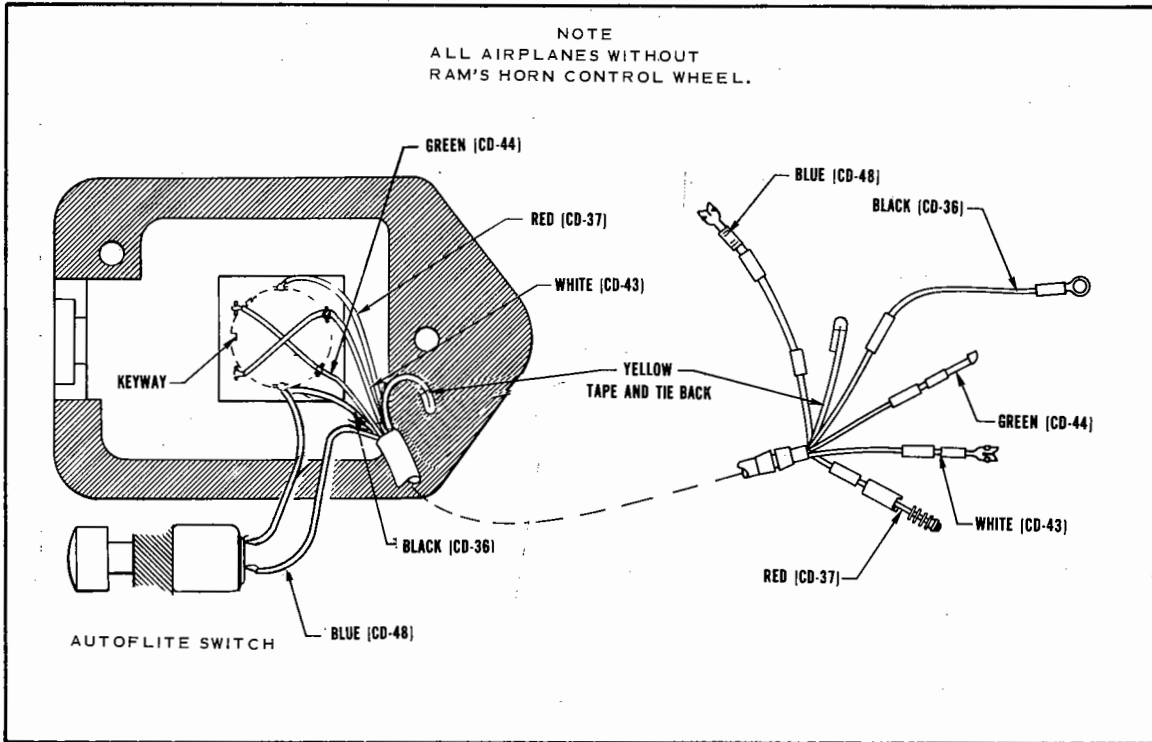

Figure 10-7. PA-23-250, PA-24 and PA-30 AltiMatic III

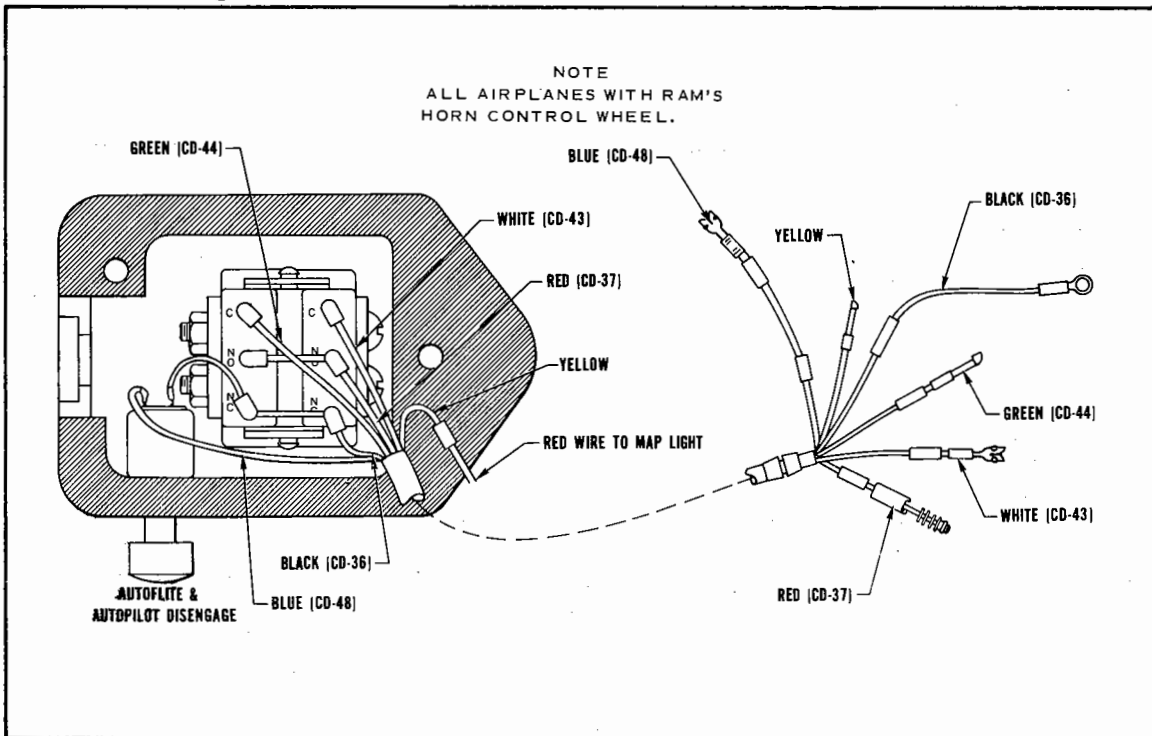

Figure 10-8. PA-24 and PA-30 AltiMatic III

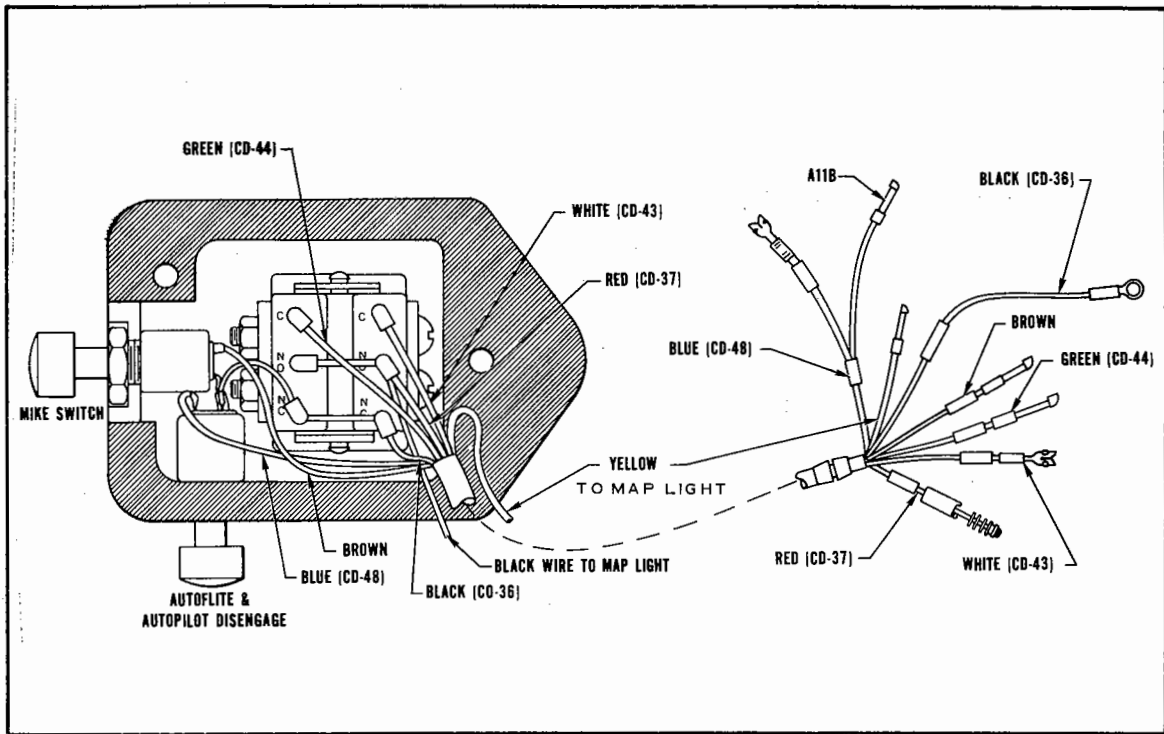

Figure 10-9. PA-24, PA-30 and PA-39 AltiMatic IIIB

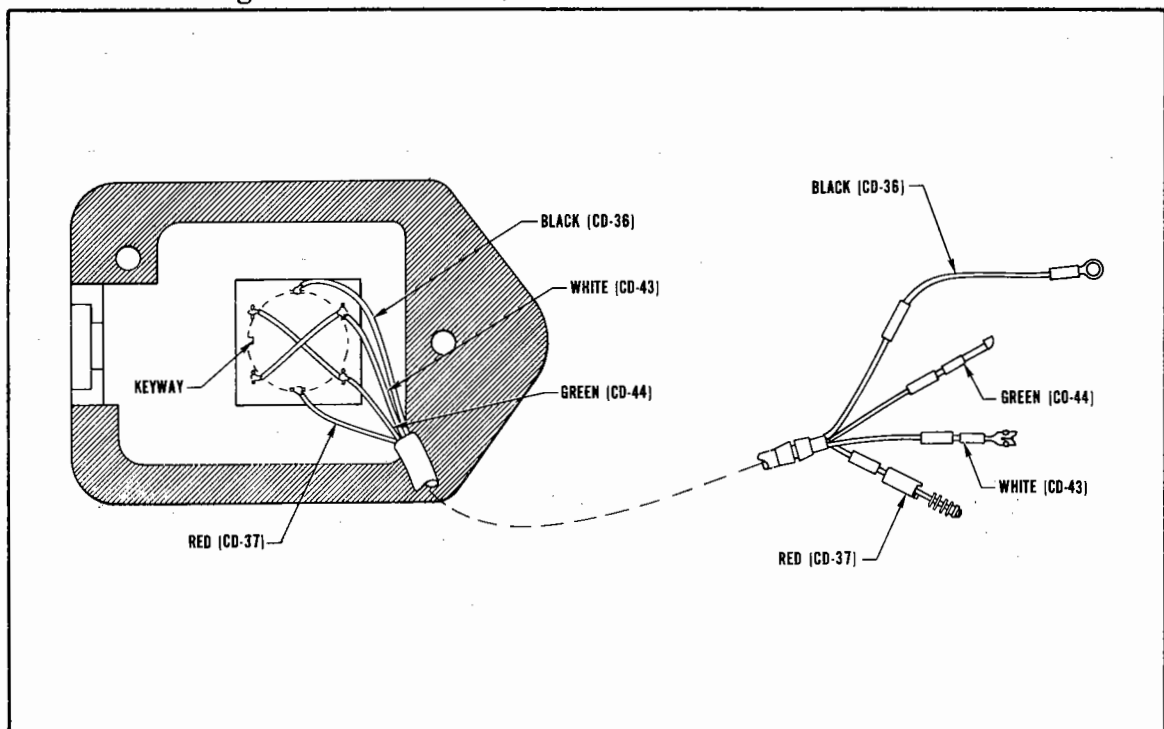

Figure 10-10. PA-32 AltiMatic III

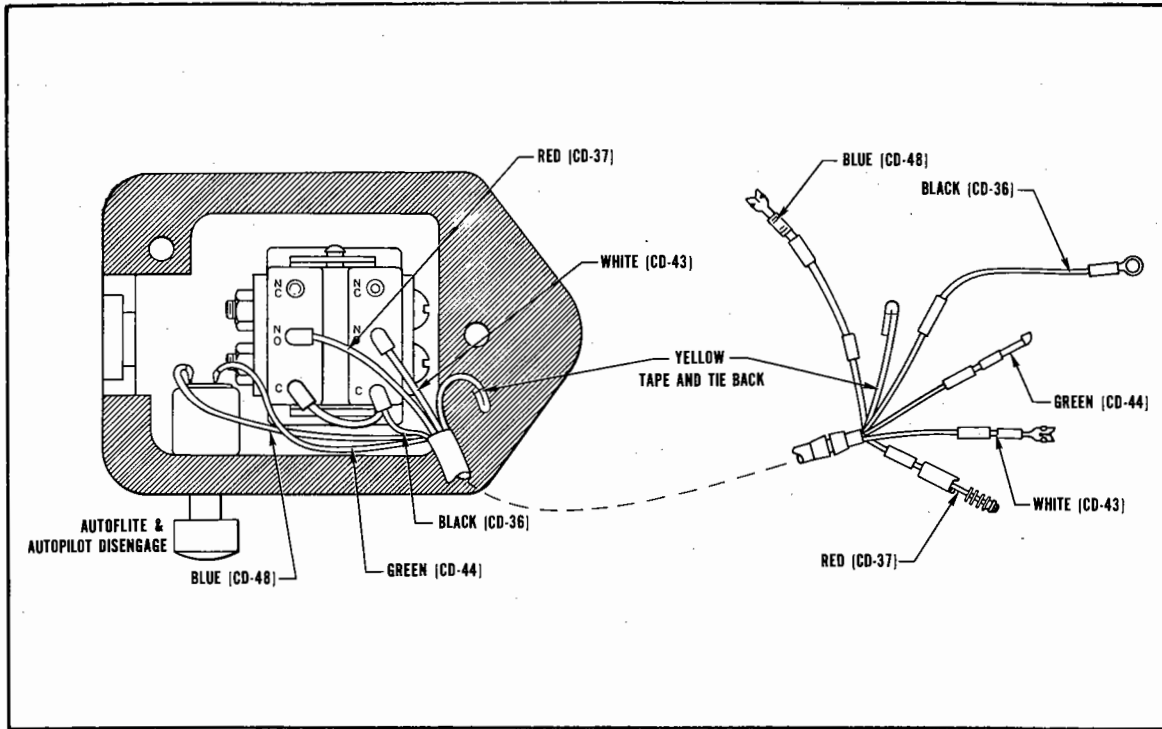

Figure 10-11. PA-31 Altimatec III & Altimatec IIIB (with trim relay)

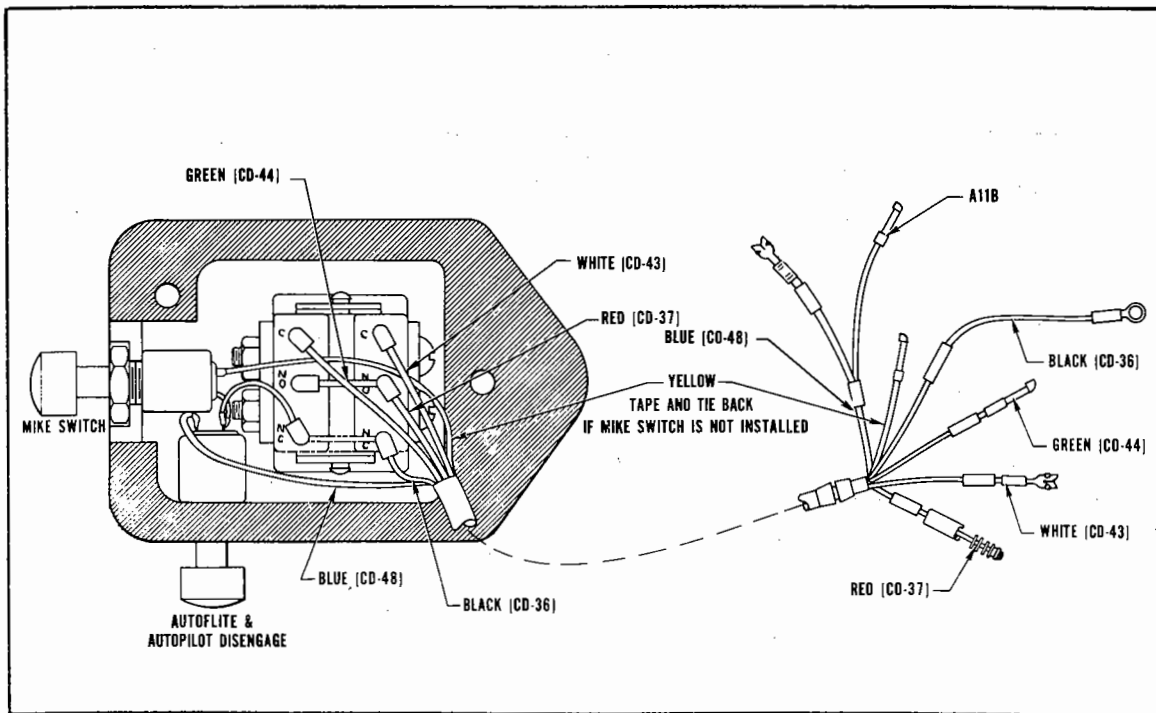

Figure 10-12. PA-31 and PA-31P Altimatec IIIB (without trim relay)

PIPER PITCH TRIM SERVICE MANUAL

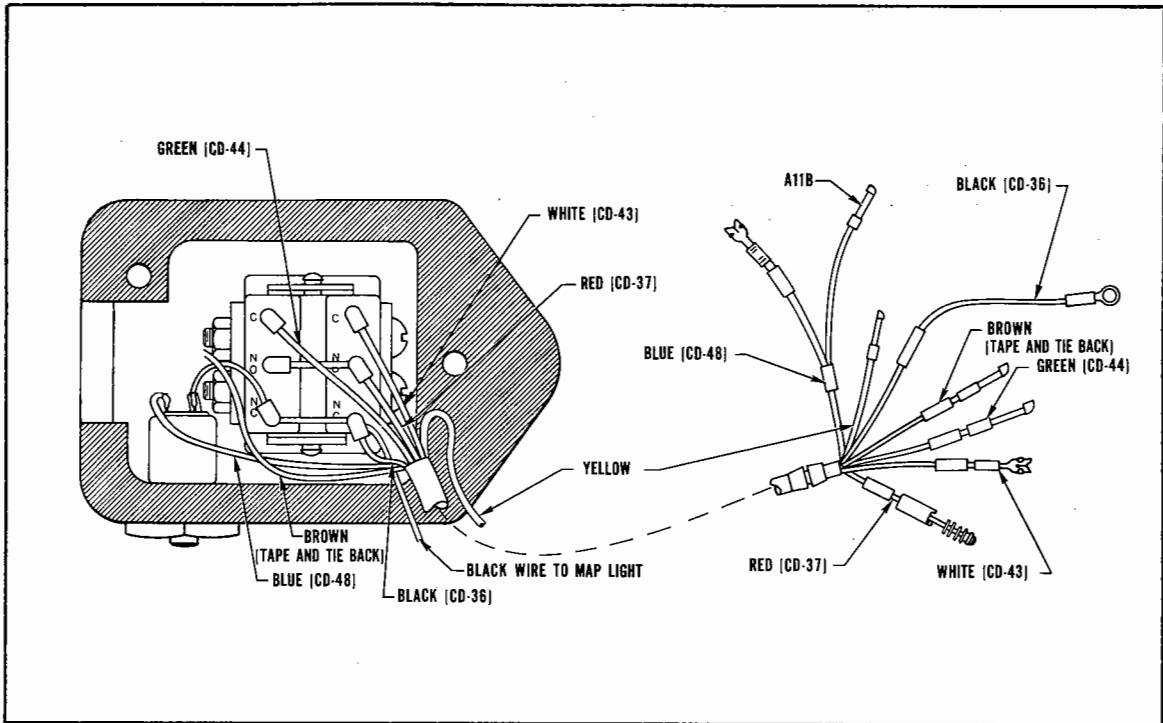

Figure 10-13. PA-24-260 and PA-39 AltiMatic IIIB-I

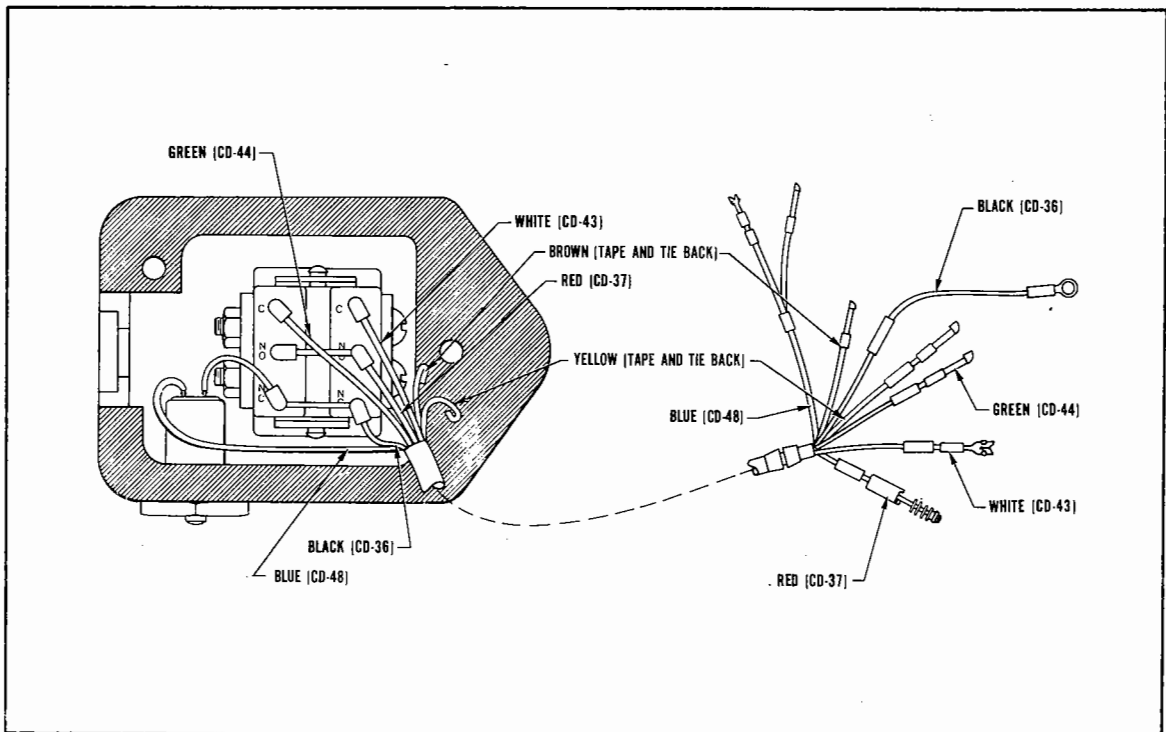

Figure 10-14. PA-31, and PA-31P AltiMatic IIIB-I

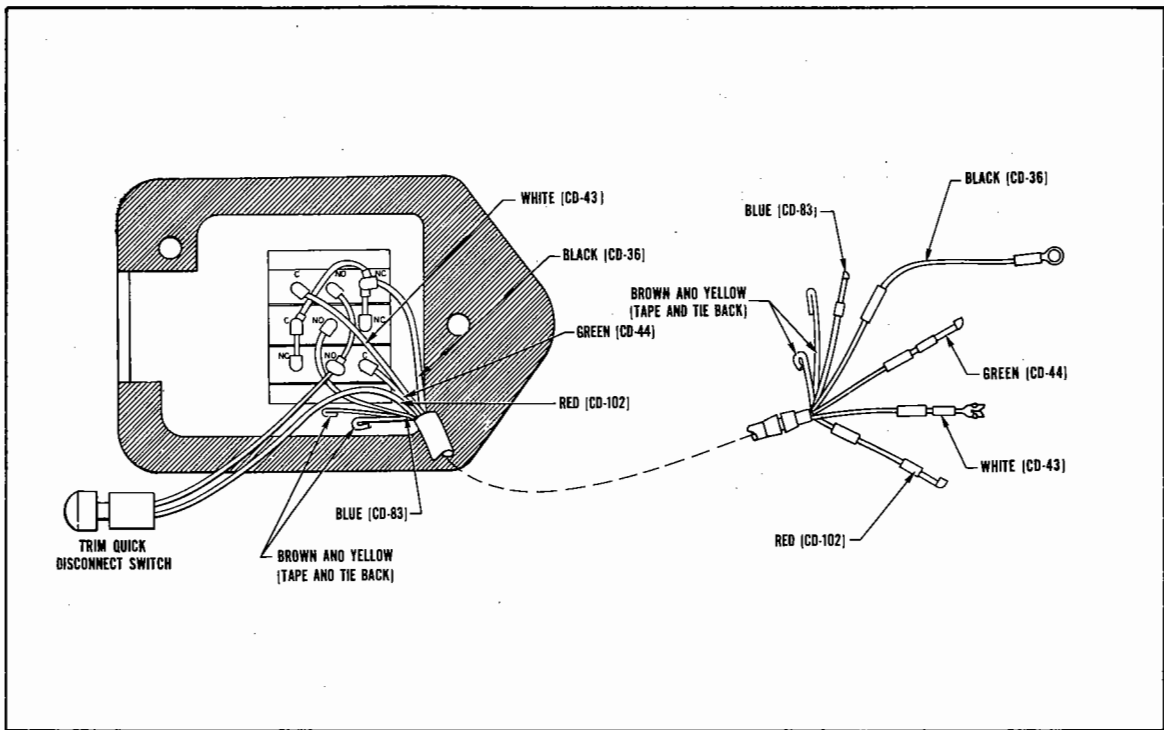

Figure 10-15. PA-31-350 AltiMatic III B-1

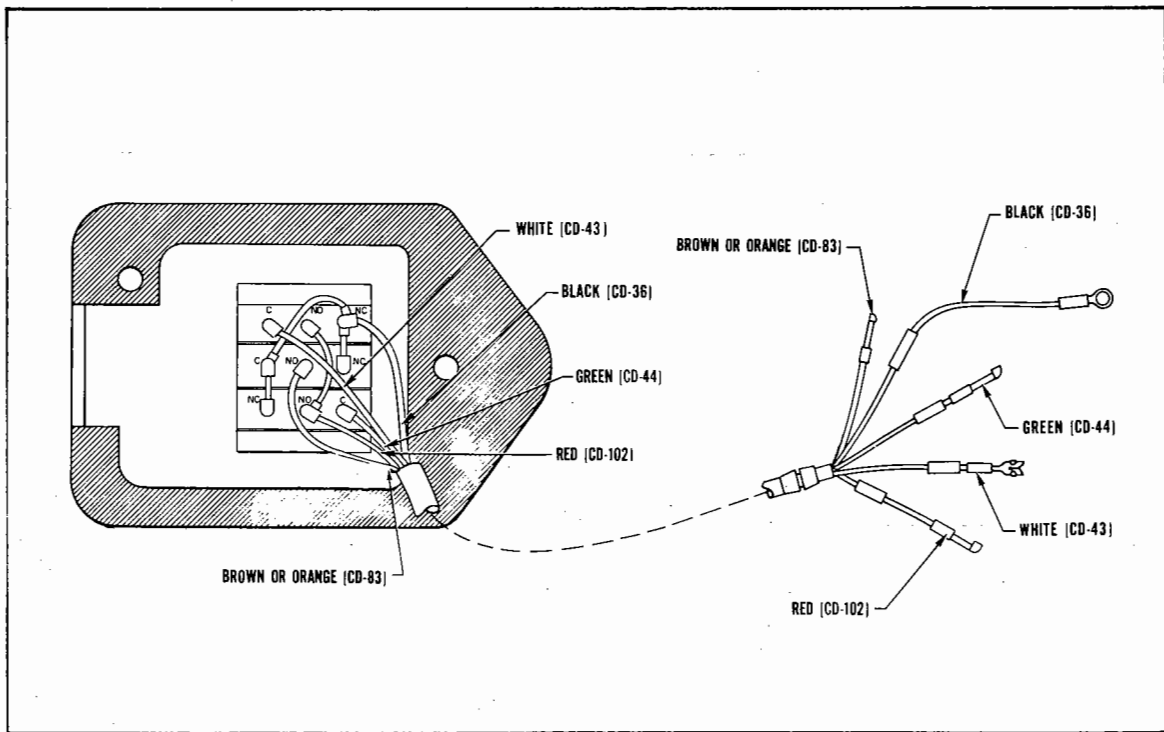

Figure 10-16. PA-34-200 AltiMatic III B-1

b. III SERIES AUTOMATIC ELECTRIC PITCH TRIM SYSTEM - AUTOMATIC MODE.

1. Place the pitch at approximately neutral position.
2. Partially engage the AltiMatic II pitch axis by rotating the PITCH ENGAGE knob to approximately 12:00 o'clock position or push the AltiMatic III Series ROLL and PITCH switches to the ON position.

NOTE

When the AltiMatic II pitch engage knob is at approximately 12:00 o'clock position or when the AltiMatic III Series ROLL and PITCH switches are ON, the pitch trim crank or wheel should rotate with noticeable resistance which will confirm that the servo selector switch has switched the electric trim to the automatic mode. The engage solenoid will be energized whenever the electric pitch trim is in the automatic mode.

3. Rotate the trim crank or wheel to check that the servo clutch has adequate torque. If the clutch torque is low, refer to Paragraph 10-3 for the trim servo clutch adjustment procedure.
4. Apply FORWARD and AFT movement to the trim switch. The trim switch should be inoperative.
5. Apply FORWARD pressure on the control wheel. The trim servo should drive the pitch trim NOSE DOWN.
6. Release the FORWARD pressure on the control wheel. The trim servo may either STOP or continue driving the pitch trim NOSE DOWN.
7. Apply AFT pressure on the control wheel. The trim servo should drive the pitch trim NOSE UP.
8. Release the AFT pressure on the control wheel. The trim servo may either STOP or continue driving the pitch trim NOSE UP.

NOTE

If the trim servo reverses direction when the forward or aft pressure on the control wheel is released, the centering of the trim sensor contacts should be checked. Refer to Section IX, Paragraph 9-31 for the trim sensor contact centering instructions.

9. Return the AltiMatic II pitch engage knob to the OFF position or the AltiMatic III Series ROLL and PITCH switches to the OFF position.

10-7. TESTING THE III SERIES AUTOMATIC PITCH TRIM WARNING SYSTEM. This section contains the information necessary to ground check the operation of the III Series Automatic Electric Pitch Trim Warning Systems installed in Piper airplanes. The following listed checks are accomplished with the airplane master switch ON and the trim circuit breaker pushed IN. Schematics for electrical circuits of the III Series Electrical Pitch Trim Systems, including the Pitch Trim Warning System, are located in Section XII of this manual.

- a. Place the pitch at approximately neutral position.
- b. Push the AltiMatic III Series Roll Engage switch and the Pitch Engage button to the IN or ON position.
- c. Push the Press-to-Test Trim Warning light on the instrument panel. With the warning light pushed and held in, the light should glow in 3 to 4 seconds.
- d. If light does not glow, check bulb and replace if necessary with correct voltage rating.
- e. If indicator light is not defective, check for A+ voltage.
- f. If the light glows but time is more or less than 3 to 4 seconds, the electronic timing device is defective and should be replaced.

10-8. TESTING THE AUTOMATIC MODE OF THE III SERIES AUTOMATIC PITCH TRIM SYSTEM USING THE TRIM SERVO TEST PLUG. (Piper P/N 757 299.)

- a. Partially engage the pitch axis of the AltiMatic II AutoPilot by rotating the pitch engage knob to approximately 12:00 o'clock position or push the AltiMatic III Series ROLL and PITCH switches to the ON position.
- b. Remove the CD-41 connector from the trim servo or trim amplifier.
- c. Place either end of the Trim Servo Test Plug in the CD-41 plug on the trim servo or trim amplifier, the trim servo should drive the trim in one direction.
- d. Place the opposite end of the Trim Servo Test Plug in the CD-41 plug on the trim servo or trim amplifier, the trim servo should drive the trim in the opposite direction.

NOTE

This test confirms that the pitch trim amplifier and servo are operational. If the manual mode operates and the automatic mode does not operate when the above tests are performed, the trim amplifier is defective.

10-9. FLIGHT CHECKS OF THE III SERIES AUTOMATIC ELECTRIC PITCH TRIM SYSTEM. This section contains the information necessary to flight check the operation of the III Series Automatic Electric Pitch Trim System used in Piper airplanes.

a. **III SERIES AUTOMATIC ELECTRIC PITCH TRIM SYSTEM - MANUAL MODE.**

1. Disengage the pitch axis of the AutoPilot.
2. Move the trim switch on the pilot's control wheel (on PA-31-350 and PA-34-200 airplanes the disengage button must be depressed, also the panel mounted and/or control wheel mounted trim quick disconnect switch must be pushed to the ON position) to the FORWARD or NOSE DOWN position.
 3. The airplane should trim NOSE DOWN.
 4. Release the trim switch, it will return to the center or OFF position.
 5. The electric power used to drive the trim servo motor will be disconnected and the airplane will continue to be trimmed NOSE DOWN until it is retrimmed to a new pitch attitude.
 6. Move the trim switch on the pilot's control wheel (on PA-31-350 and PA-34-200 airplanes the disengage button must be depressed, also the panel mounted and/or control wheel mounted trim quick disconnect switch must be pushed to the ON position) to the AFT or NOSE UP position.
 7. The airplane should trim NOSE UP.
 8. Release the trim switch, it will return to the center or OFF position.
 9. The electric power used to drive the trim servo motor will be disconnected and the airplane will continue to be trimmed NOSE UP until it is retrimmed to a new pitch attitude.
 10. If the trim system fails to react to either NOSE UP or NOSE DOWN, check that the trim circuit breaker, the panel mounted and/or control wheel mounted trim quick disconnect switch is pushed to the ON position. If the pitch trim still does not operate, the control wheel switch and wiring should be checked to see if it is defective.

b. **III SERIES AUTOMATIC ELECTRIC PITCH TRIM SYSTEM - AUTOMATIC MODE.**

1. Engage the roll and pitch axis of the AutoPilot.
2. The Automatic Pitch Trim will at all times keep the airplane trimmed for any attitude of the AutoPilot.
3. When the AltiMatic II or AltiMatic III pitch axis is disengaged the airplane should be trimmed to the attitude at the time of AutoPilot disengagement. If an out of trim condition exists at time of AutoPilot disengagement, the trim sensor centering procedure in Section IX, Paragraph 9-31 should be checked.

NOTE

When engaging the AutoPilot, observe the trim crank. If the trim crank turns in either direction in excess of 1/3 of a complete turn, check the trim sensor centering in Section IX, Paragraph 9-31.

SECTION XI

TEST EQUIPMENT

Paragraph		Page
11-1.	Introduction - 66B83-1 Output Meter	11-1
11-2.	Trim Servo Adapter Plug	11-1

SECTION XI

TEST EQUIPMENT

11-1. INTRODUCTION - 66B83-1 OUTPUT METER. (Refer to Figure 11-1.)

a. The 66B83-1 Output Meter is used in conjunction with Output Cable 30A177 and Adapter Cable 66A119.

b. This meter is used for the following purposes and can be used for various tests, not limited to what is given in this description.

1. Finding the "center" of the contact points on the trim sensor.
2. Checking for trim sensor switch operation in both directions.

The meter incorporates a dummy load and can be read direct. The Output Meter consists of a center reading meter and an Alden receptacle to be used in conjunction with the Output Cable 30A177. Refer to the trim sensor centering instructions in Section IX, Paragraph 9-25 for the instructions on the use of the Output Meter and cables.

11-2. TRIM SERVO TEST PLUG. (Refer to Figure 11-2.)

a. The Trim Servo Test Plug is used for troubleshooting the automatic mode of the III Series Automatic Electric Pitch Trim System.

b. The Trim Servo Test Plug is used for the following purposes:

1. Verify that the trim amplifier and trim servo are operational in the automatic mode.
2. Used as a substitute for the trim sensor and trim sensor electrical cable.

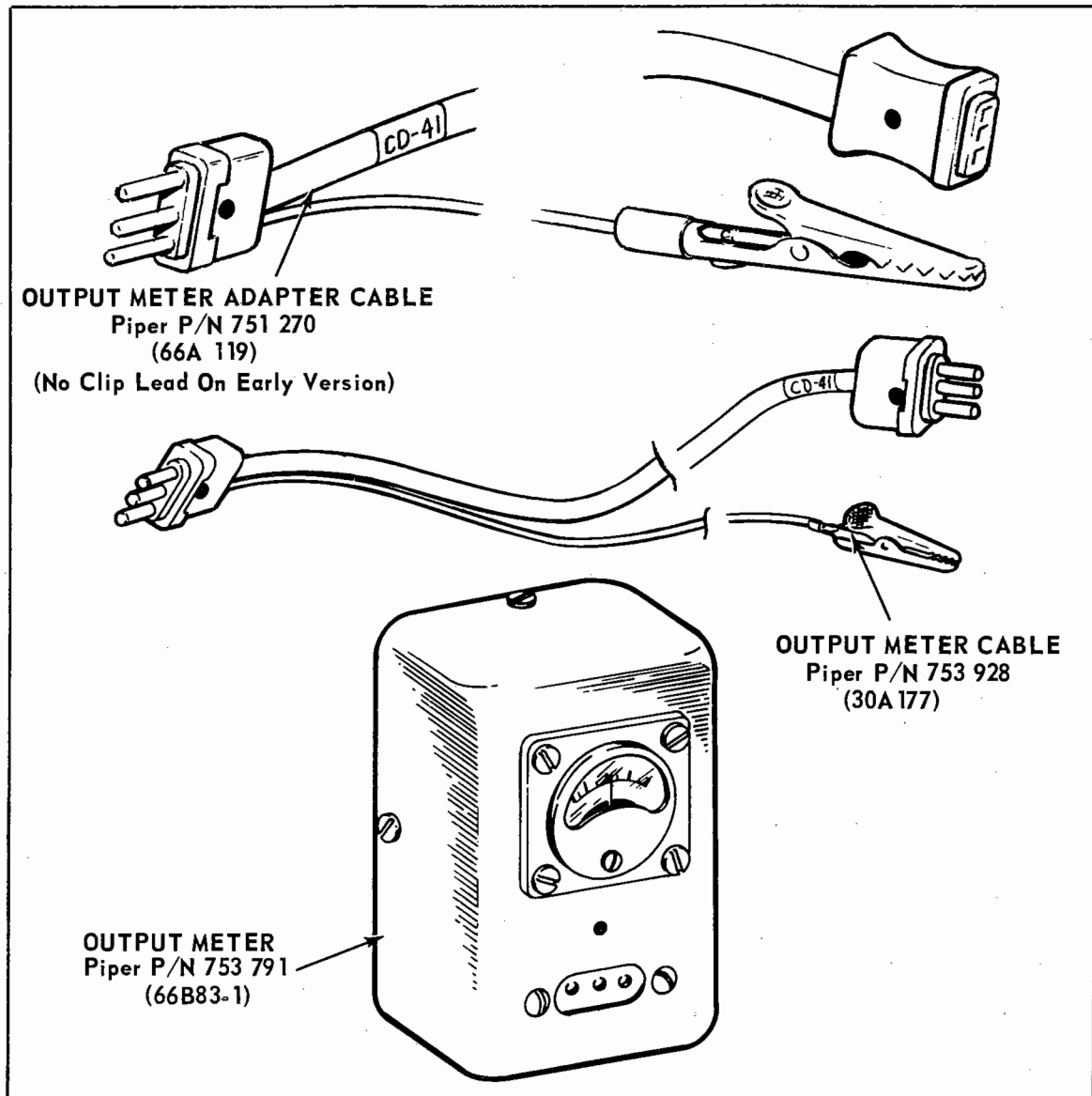

Figure 11-1. Test Equipment

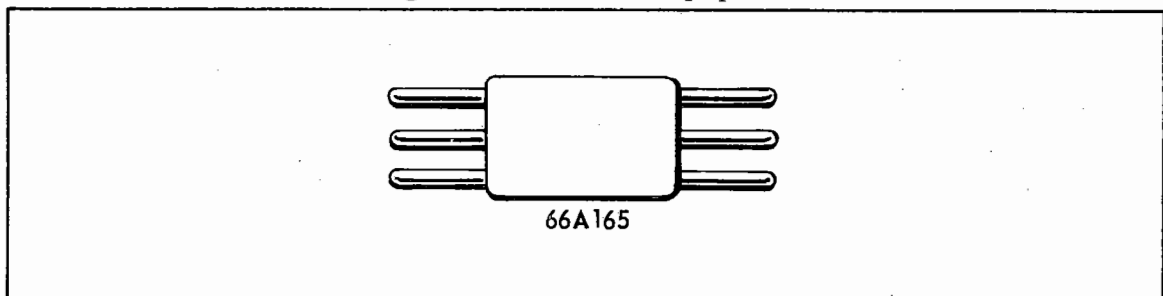

Figure 11-2. Trim Servo Test Plug, Piper P/N 757 299

SECTION XII

SCHEMATICS

Paragraph		Page
12-1.	Introduction	12-1

SECTION XII

SCHEMATICS

12-1. INTRODUCTION. This section of the manual consists of schematic diagrams of the electrical circuitry of the III Series Automatic Electric Pitch Trim System installed in Piper airplanes. The schematic diagrams should be used as an aid in troubleshooting the electrical portion of the trim system.

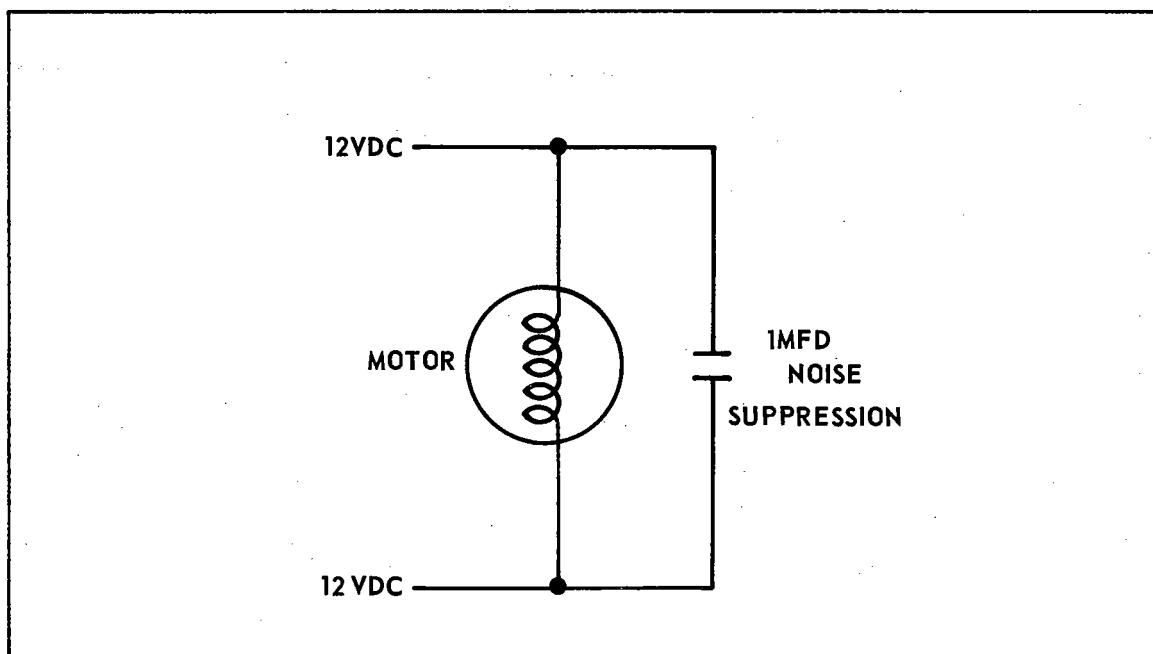

Figure 12-1. III Series Automatic Pitch Trim Servo Motor

THIS PAGE INTENTIONALLY LEFT BLANK

PART III

M.E.T.

(MANUAL ELECTRIC TRIM)

SYSTEMS

SECTION XIII

INTRODUCTION AND DESCRIPTION

Paragraph		Page
13-1.	Introduction	13-1
13-2.	Description	13-1

SECTION XIII

INTRODUCTION AND DESCRIPTION

13-1. INTRODUCTION. This part of the Service Manual is divided into six sections. Section XIII contains a description of the Piper M. E. T. - 3 Electric Pitch Trim System. M. E. T. is the abbreviation for Manual Electric Trim which is a vendor designed and manufactured system. Section XIV, Theory of Operation, explains the operation of the system. Section XV, Removal and Installation, provides the information necessary for removal and installation of the components of the system. Section XVI, Adjustment Procedures and Operational Checks, provides the information necessary to check the operation of the system and perform minor adjustments. Section XVII, Test Equipment, provides information on the equipment required to check the system. Section XVIII, Schematics, provides the schematic of the system for troubleshooting purposes.

13-2. DESCRIPTION. The M. E. T. - 3 Electric Pitch Trim System is a system which trims the pitch axis of the airplane electrically. The operation of the system will be explained in Section XIV. The M. E. T. - 3 utilizes solenoid engage and incorporates the use of a permanent magnet type motor. By utilizing the control wheel mounted trim switch, the pilot can control the direction of trim (up and down) and the amount of trim. When servicing the Piper Electric Trim Systems, the serviceman must determine which system is installed in the airplane being serviced to determine the service procedures to be used.

NOTE

A simplified block diagram in Table XIV-I and an identifying features diagram in Table XIV-II is presented in Section XIV of this manual. These diagrams illustrate the basic components and features of the M. E. T. - 3 Electric Pitch Trim System.

SECTION XIV

THEORY OF OPERATION

Paragraph	Page
14-1.	14-1
Description	

SECTION XIV

THEORY OF OPERATION

14-1. DESCRIPTION. The M. E. T. - 3 Electric Pitch Trim System is available for use anytime an AltiMatic AutoPilot is not installed. Trim may be accomplished by the human pilot by use of the trim switch on the pilot's control wheel, which is spring-loaded to the center or OFF position. There are two different types of trim switches installed in Piper airplanes. On installations utilizing the standard slide switch, movement of the switch in either direction will actuate the trim system. On installations utilizing the upright trim switch with a small trim button incorporated on the switch, the small trim button must be depressed when moving the switch in either direction to actuate the trim system. When operating the M. E. T. - 3 systems, keep in mind the different actuating procedures required for each trim switch. When either switch is moved to the forward position, it completes a circuit to the servo motor, supplying voltage of a proper polarity to assure rotation of the motor in the correct direction. At the same time, the switch supplies power to a solenoid which engages the trim servo motor to the capstan through a set of gears. Since the trim system cables are wrapped around the capstan, any rotation of the trim servo motor results in a change of position of the airplane's trim system, thus deflecting the stabilator or elevator trim tab in the conventional manner. When the human pilot releases the switch, it returns to the OFF position and power is then disconnected from the trim servo motor and the engage solenoid which completely disengages the electric trim motor from the airplane's trim system cables. If the switch is moved to the rear position, the same events occur except the polarity of the servo motor is reversed insuring the opposite direction of rotation.

Stabilator or Elevator control cable tension is important for the correct operation of this system, and the appropriate trim cable tension must be set according to the appropriate airframe service manual.

TABLE XIV-I. SIMPLIFIED BLOCK DIAGRAM
M. E. T. SERIES ELECTRIC PITCH TRIM SYSTEM

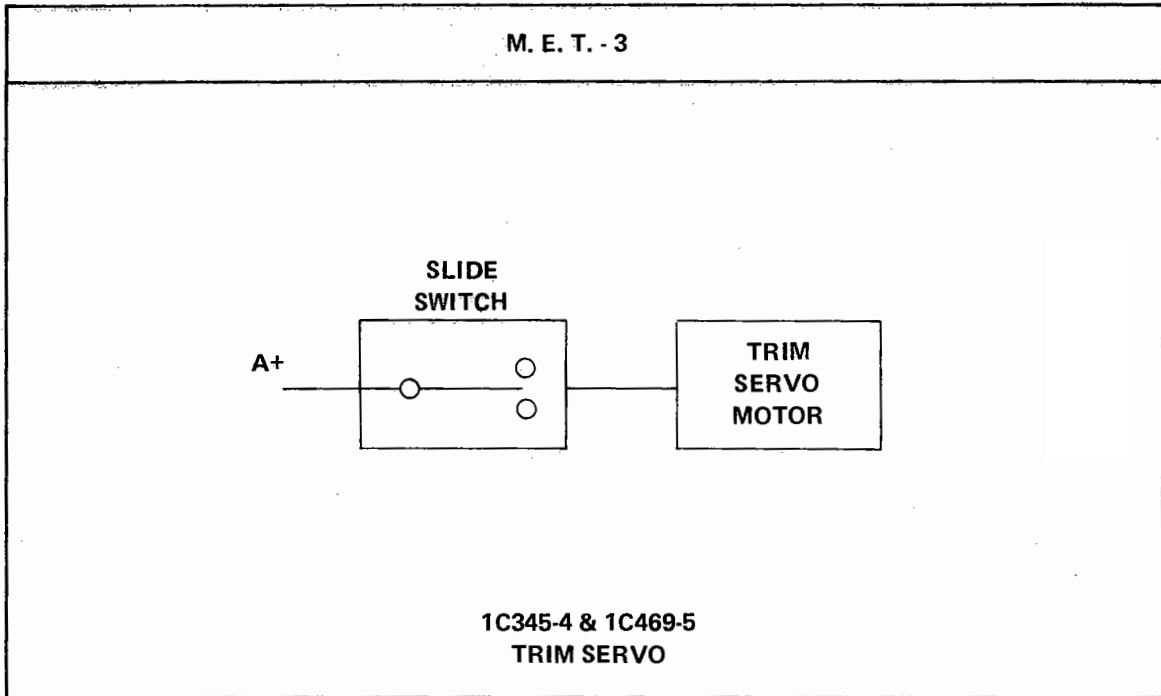

TABLE XIV-II. IDENTIFYING FEATURES
M. E. T. SERIES ELECTRIC PITCH TRIM SYSTEM

M. E. T. - 3
<p>SLIDE SWITCH ON CONTROL WHEEL TRIM SERVO PERMANENT MAGNET MOTOR NO DISK ON CAPSTAN</p>

SECTION XV

REMOVAL AND INSTALLATION

Paragraph		Page
15-1.	Introduction	15-1
15-2.	Removal of Trim Servo - PA-23-250	15-1
15-3.	Installation of Trim Servo - PA-23-250	15-1
15-4.	Removal of Trim Servo - PA-24-260, PA-30 and PA-39	15-3
15-5.	Installation of Trim Servo - PA-24-260, PA-30 and PA-39	15-4
15-6.	Removal of Trim Servo - PA-34-200 and PA-34-200T	15-5
15-7.	Installation of Trim Servo - PA-34-200 and PA-34-200T	15-5

SECTION XV

REMOVAL AND INSTALLATION

15-1. INTRODUCTION. The instructions in this section provide the removal and installation of the components of the M. E. T. - 3 Electric Pitch Trim Systems used in Piper airplanes. Checks and Adjustments are limited to those required for removal and installation of the components. Sequential tests and adjustment procedures are found in the sections to follow. When any component of the system is installed a complete functional check of the system must be made to confirm correct system operation. When using this section refer to the appropriate removal and installation instructions for the airplane being serviced. To maintain cable routing of the trim cable during removal and installation of trim servos, it is recommended that the service aids shown in Figure 15-1 be utilized. Service aids as shown can be fabricated locally from shop material.

15-2. REMOVAL OF TRIM SERVO. (PA-23-250.) The trim servo is located in the top aft rear baggage compartment.

- a. Access to the servo is through the aft baggage compartment door.
- b. Remove the box type trim panel forward of the baggage compartment dome light by removing the six attaching screws.
- c. Remove attaching screws from the hat shelf panel in rear baggage compartment and remove panel.
- d. Remove attaching screws in aft panel of rear baggage compartment and remove panel to gain access to turnbuckles to release cable tension.
- e. Disconnect the electrical connection from the servo assembly.
- f. Remove the four bolts securing the servo assembly to the mounting brackets.
- g. Unwrap trim cable from capstan and idler pulley and remove servo assembly from the airplane.

15-3. INSTALLATION OF TRIM SERVO. (PA-23-250.) (Refer to Figure 15-2.)

- a. Position the trim servo on the mounting brackets and secure with mounting bolts.
- b. Route the trim cable from the forward part of the airplane around the top capstan groove to the idler pulley and around the bottom capstan groove to the aft section of the airplane, completing a figure eight.
- c. Tighten the trim cable to obtain appropriate tension as listed in Table XV-I.
- d. Connect the electrical connection to the servo and check servo operation.
- e. Install aft panel in rear baggage compartment and secure with appropriate screws.
- f. Install hat shelf panel in rear baggage compartment and secure with appropriate screws.
- g. Install box type trim panel forward of baggage compartment dome light and secure with attaching screws.

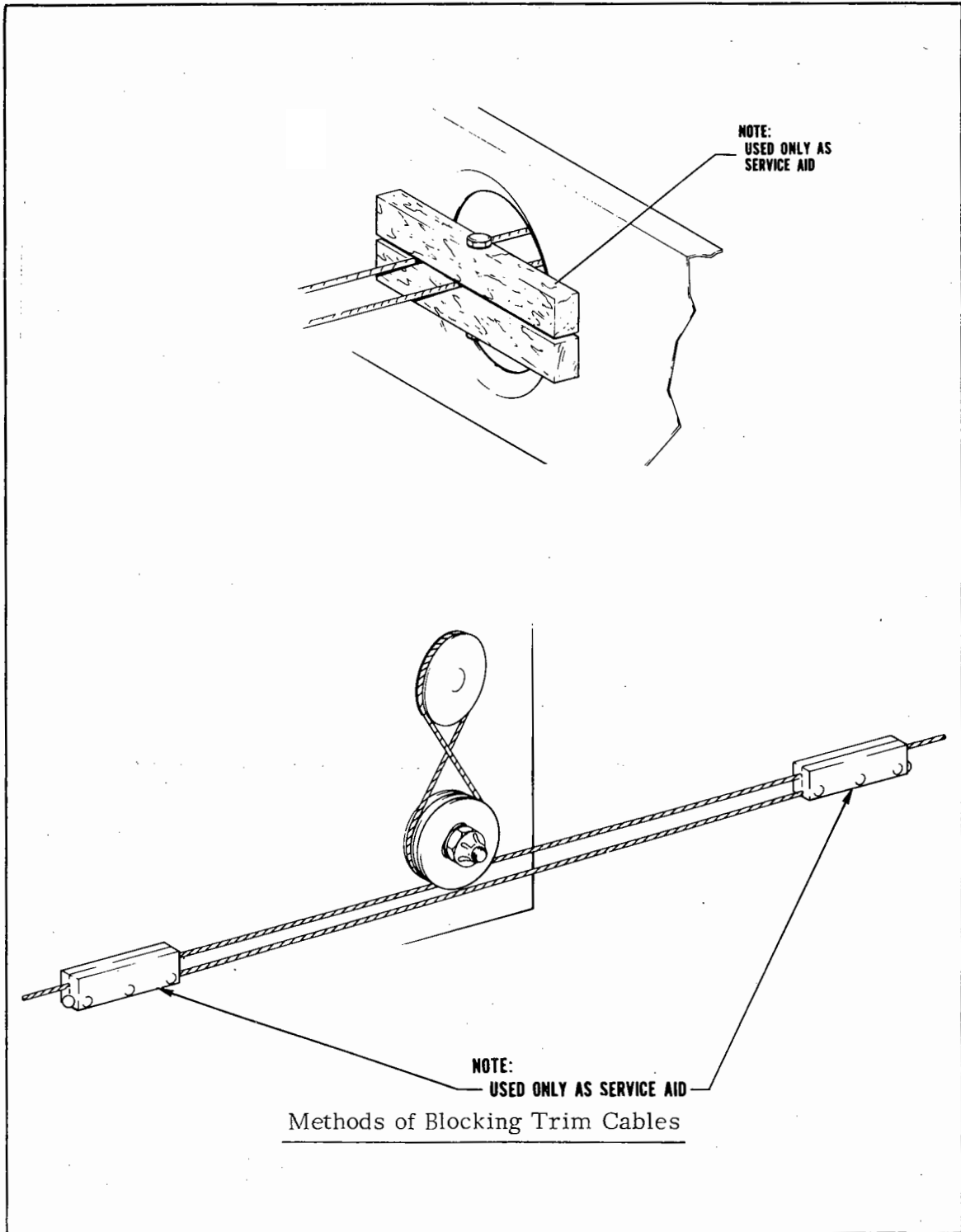

Figure 15-1. Servicing Aids

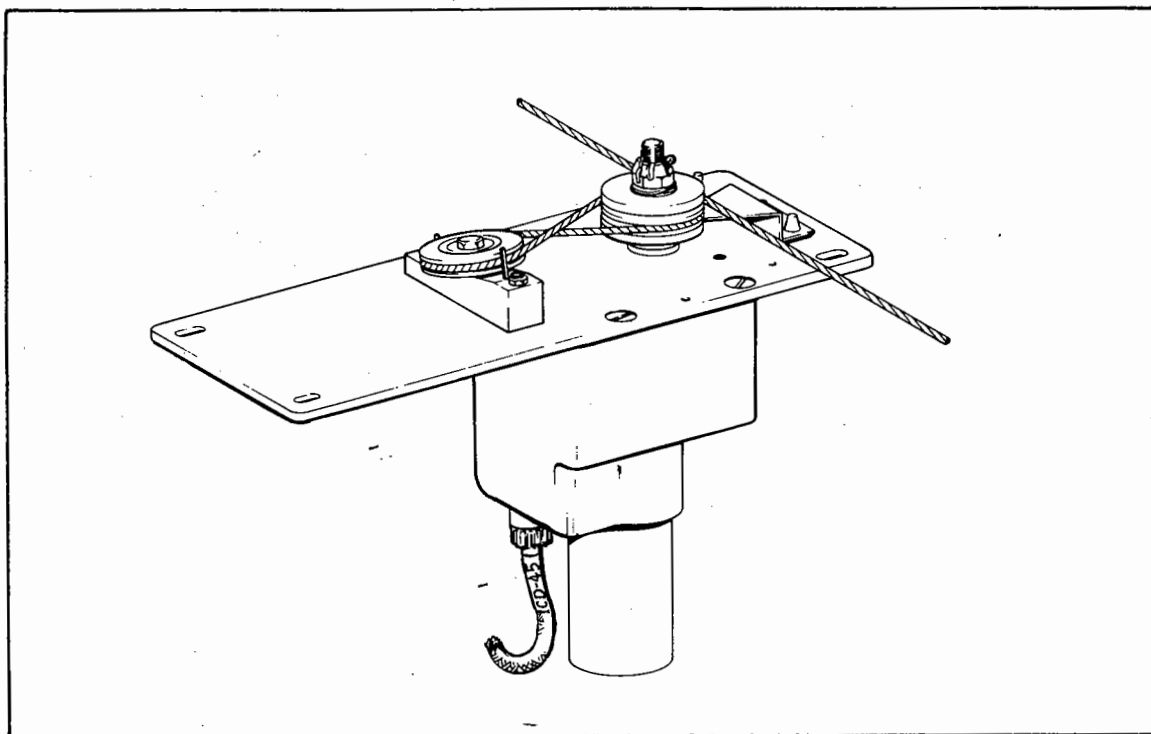

Figure 15-2. PA-23-250, PA-24-260, PA-30 and PA-39 Trim Servo Cable Routing

15-4. REMOVAL OF TRIM SERVO. (PA-24-260, PA-30 and PA-39.)

The trim servo is located aft of the baggage compartment on the upper fuselage.

NOTE

When servicing six-place airplanes, the 5th and 6th seats must be removed before proceeding with the following instructions.

- a. Access to the servo is through the baggage compartment.
- b. Remove attaching screws from left rear window trimstrip and remove trimstrip.
- c. Remove attaching screws from the hat shelf panel and remove panel by pushing right side of panel aft to force left side of panel forward to free panel from right rear window trimstrip.
- d. Remove attaching screws from aft panels in rear baggage area and remove panels to gain access to turnbuckles to release cable tension.
- e. Disconnect the electrical connection from the servo assembly.
- f. Remove the four bolts securing the servo assembly to the mounting bracket.
- g. Unwrap trim cable from capstan and idler pulley and remove servo assembly from the airplane.

15-5. INSTALLATION OF TRIM SERVO. (PA-24-260, PA-30 and PA-39.) (Refer to Figure 15-2.)

- a. Position the trim servo on the mounting bracket and secure with mounting bolts.
- b. Route the trim cable from the forward part of the airplane around the top capstan groove to the idler pulley and around the bottom capstan groove to the aft section of the airplane, completing a figure eight.
- c. Tighten the trim cable to obtain appropriate tension as listed in Table XV-I.
- d. Connect the electrical connection to the servo and check servo operation.
- e. Install aft panels in rear baggage area and secure with attaching screws.
- f. Install hat shelf panel and left rear window trimstrip and secure with attaching screws.

TABLE XV-I. TRIM SERVO CABLE TENSION

AIRPLANE	CABLE	CABLE TENSION
PA-23-250	Stabilator Trim	15 lbs. \pm 20% (3lbs.)
PA-24-260	Stabilator Trim	12 lbs. \pm 20% (2.4 lbs.)
PA-30	Stabilator Trim	12 lbs. \pm 20% (2.4 lbs.)
PA-34-200 and PA-34-200T	Stabilator Trim	10 lbs. \pm 20% (2 lbs.)
PA-39	Stabilator Trim	12 lbs. \pm 20% (2.4 lbs.)

15-6. REMOVAL OF TRIM SERVO. (PA-34-200 and PA-34-200T.) The trim servo is located aft of the rear baggage area on the lower fuselage.

- a. Access to the servo is through the rear baggage area.
- b. Remove the access plate in the lower right side of aft panel in rear baggage area by turning the screw type fasteners to release the panel.
- c. Loosen trim cable turnbuckles to release cable tension.
- d. Disconnect the electrical connection from the servo.
- e. Remove the four mounting bolts securing the servo to the mounting brackets.
- f. Unwrap trim cable from capstan and idler pulleys and remove servo from the airplane.

15-7. INSTALLATION OF TRIM SERVO. (PA-34-200 and PA-34-200T.) (Refer to Figure 15-3.)

- a. Position the trim servo on the mounting brackets and secure with appropriate nuts and bolts.
- b. Route the trim cable from the forward part of the airplane around the aft inboard idler pulley, then around the bottom capstan groove and around the aft outboard idler pulley, continuing around the forward outboard idler pulley and around the top capstan groove to the forward inboard idler pulley, to the aft section of the airplane.
- c. Tighten the trim cable to obtain appropriate tension as listed in Table XV-I.
- d. Connect the electrical connection to the trim servo and check servo operation.
- e. Install access plate in lower right side of aft panel in rear baggage area and turn screw type fasteners to secure access plate.

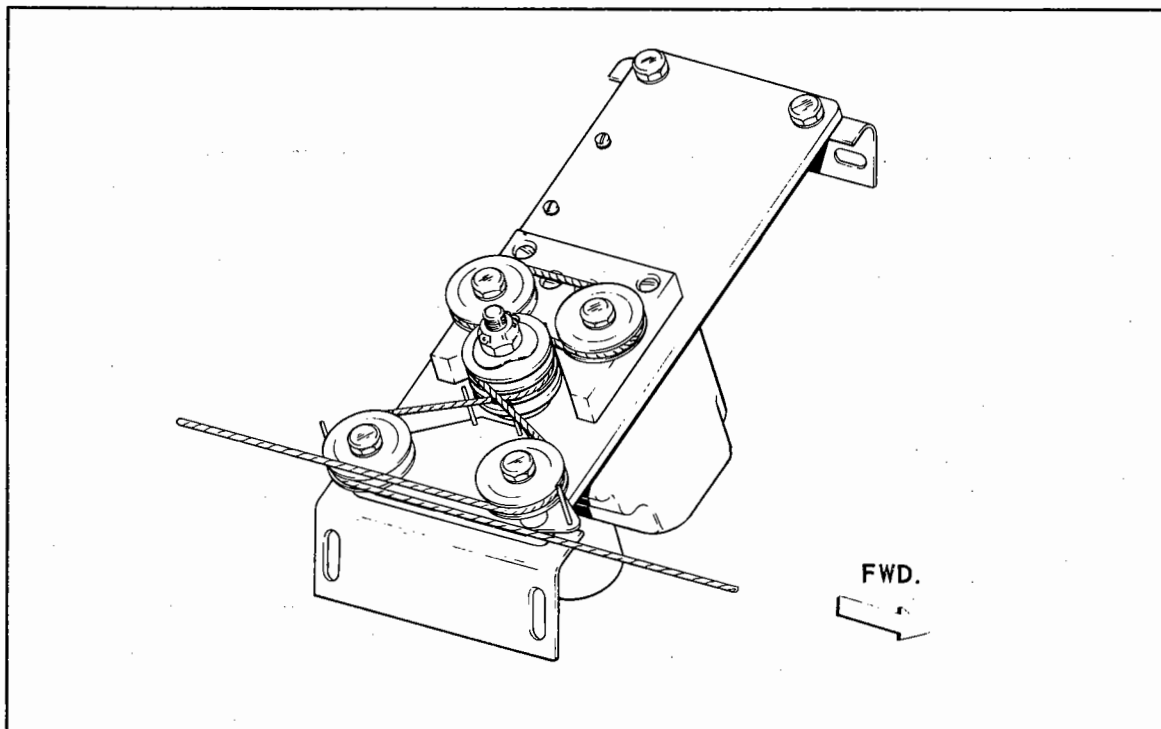

Figure 15-3. PA-34-200 and PA-34-200T Trim Servo Cable Routing

SECTION XVI

ADJUSTMENT PROCEDURES AND OPERATIONAL CHECKS

Paragraph		Page
16-1.	Description	16-1
16-2.	Control Wheel Harness Connections	16-1
16-3.	M. E. T. - 3 Trim Servo Clutch Adjustment Procedure	16-1
16-4.	Checking Trim Servo Motor Current Drain (No Load)	16-3
16-5.	Ground Checks for M. E. T. - 3 Electric Pitch Trim System	16-6
16-6.	Flight Checks of the M. E. T. - 3 Electric Pitch Trim System	16-6

SECTION XVI

ADJUSTMENT PROCEDURES AND OPERATIONAL CHECKS

16-1. DESCRIPTION. This section provides the information necessary to properly adjust and perform operational checks of the M. E. T. -3 Electric Pitch Trim System. The first part consists of servo adjustments and wiring connections for the control wheel trim switch. The second part consists of operational checks of the M. E. T. -3 Electric Pitch Trim System.

16-2. CONTROL WHEEL HARNESS CONNECTIONS. The pitch trim switch is mounted in the control wheel and is electrically connected to the components of the trim system through a coiled harness assembly. The connections for each different installation are shown in illustration form in this section. When replacing a defective switch, refer to Figures 16-3 thru 16-5 for the proper wiring connections to be made on the airplane being serviced.

16-3. M. E. T. -3 TRIM SERVO CLUTCH ADJUSTMENT PROCEDURE.

NOTE

This adjustment procedure requires two servicemen.

- a. Attach a 0-50 lb. spring scale to the trim tab cable which is attached to the trim servo. (Refer to Figure 16-1.)
- b. Turn the airplane master switch on.
- c. Using pilot's trim switch, actuate trim system in direction away from scale.
- d. Hold scale steady and note reading at which clutch slips. Clutch tolerance is listed in Table XVI-I for each type airplane.
- e. To adjust clutch, refer to Figure 16-2 and proceed as follows:
 1. Remove the cotter pin item #1 from the clutch tension nut.
 2. Rotate the clutch tension nut item #2 in the desired direction to obtain specified setting.

NOTE

Clockwise rotation of the nut increases clutch tension, Counterclockwise rotation of the nut decreases clutch tension. There are two holes drilled through the capstan shaft. One-half castellation movement of the nut will change the tension approximately five pounds.

TABLE XVI-I. M. E. T. SERIES TRIM SERVO CLUTCH TENSION

AIRPLANE	SERVO NO.	CLUTCH SETTING
PA-23-250 (14-volt)	1C345-4	25 ± 5 lbs.
PA-23-250 (28-volt)	1C463-5	25 ± 5 lbs.
PA-24-260	1C345-4	25 ± 5 lbs.
PA-30	1C345-4	25 ± 5 lbs.
PA-34-200 and PA-34-200T	1C345-4	20 ± 5 lbs.
PA-39	1C345-4	25 ± 5 lbs.

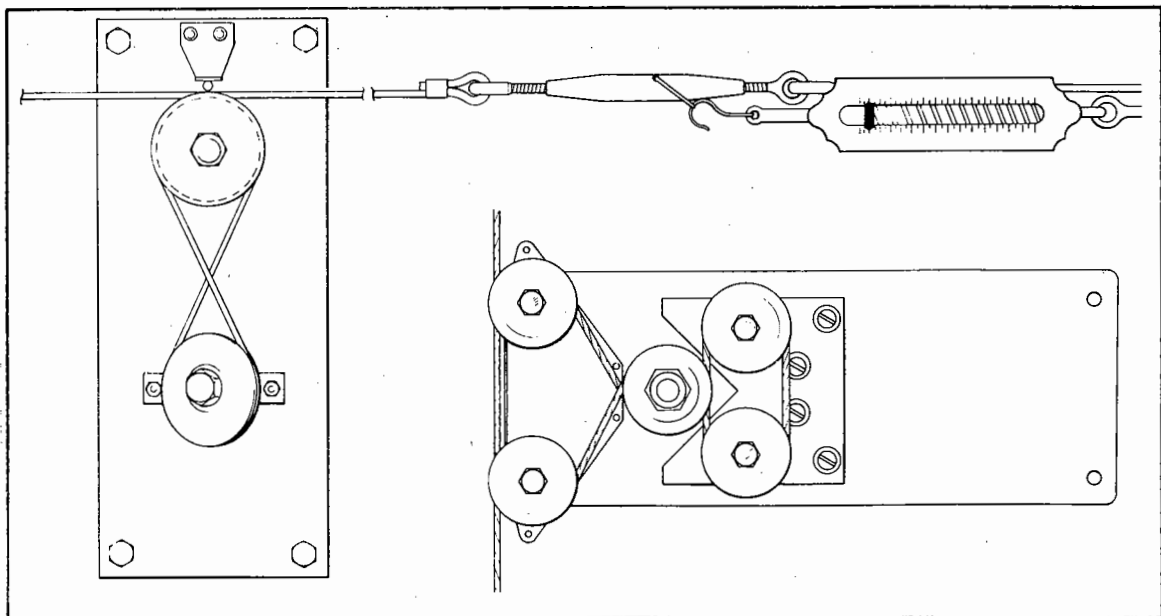

Figure 16-1. M. E. T. Series Trim Servo Clutch Adjustment

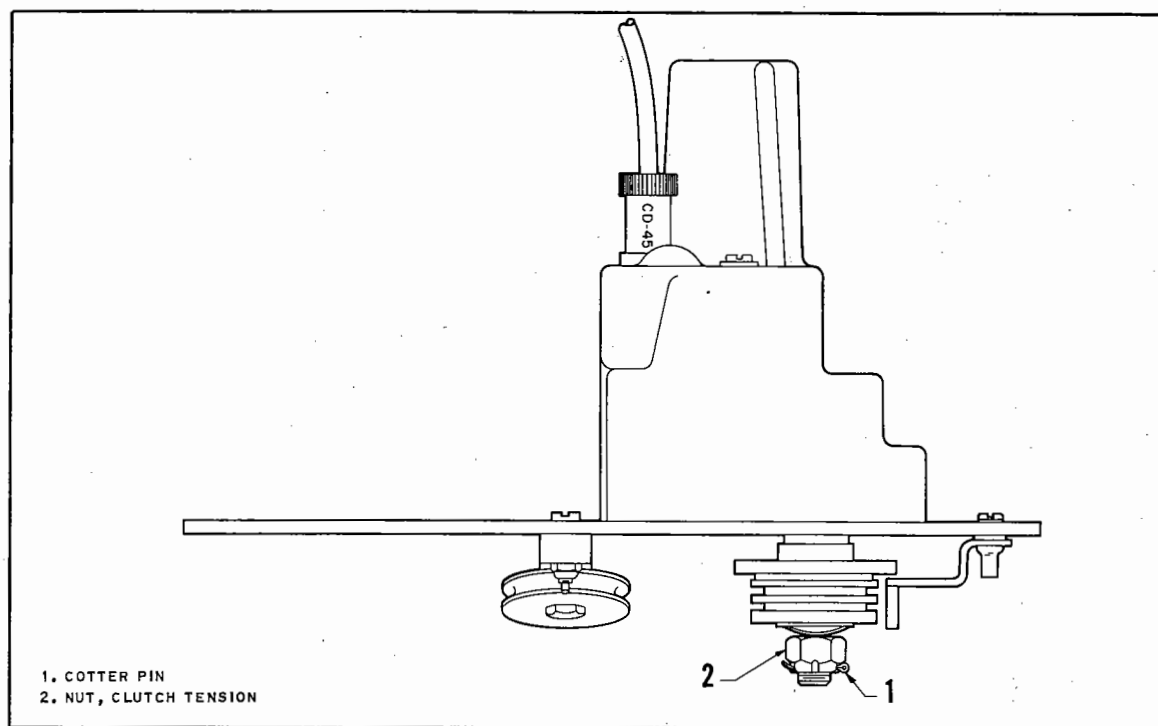

Figure 16-2. Clutch Adjustment Detail

16-4. CHECKING TRIM SERVO MOTOR CURRENT DRAIN (NO LOAD).

The servo motor may be checked in the airplane for current drain using a standard ammeter (or equivalent) in series with the motor. The following procedure will facilitate this check.

NOTE

If the servo motor current drain is over one-half amp, it must be replaced.

- a. Disconnect the electrical connection from the servo.
- b. It shall be necessary to improvise an adapter for the CD-45 plug.
- c. Connect negative side of a 12 volt source to pin D of the servo motor connector.
- d. Connect one lead from the ammeter to pin C of the servo motor connector.
- e. Connect the positive side of the 12 volt source to the remaining lead from the ammeter.

CAUTION

Prior to applying voltage, as described in the following steps, the initial application of voltage should only be for ONE second to ascertain there are no shorts which will damage the meter.

- f. Apply voltage from the 12 volt source for ONE second, to ascertain no shorts exist.
- g. Apply voltage from the 12 volt source and take current reading. Turn off voltage after reading has been obtained.
- h. To check the motor operation in the opposite direction, reverse connections C and D on the servo motor connector and apply voltage and take current reading. Turn off voltage after reading has been obtained.
- i. If the reading is over one-half amp for either direction of servo motor operation, the servo must be replaced.

NOTE

Motor must be tested in both directions.

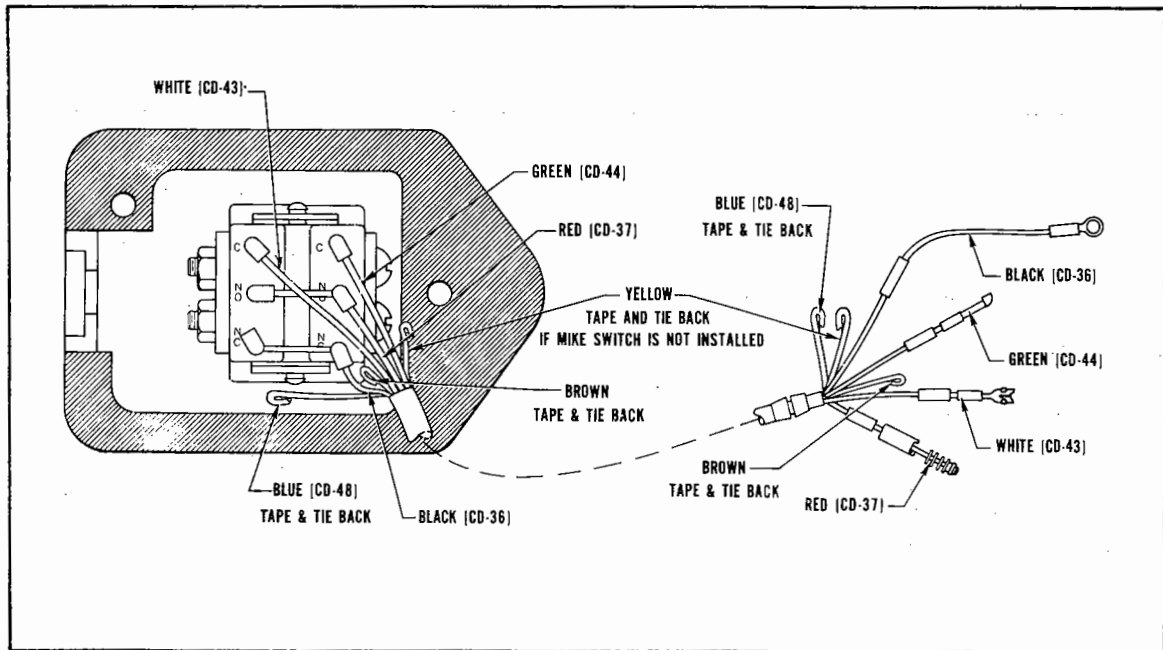

Figure 16-3. PA-23-250 M. E. T. - 3
Control Wheel Switch

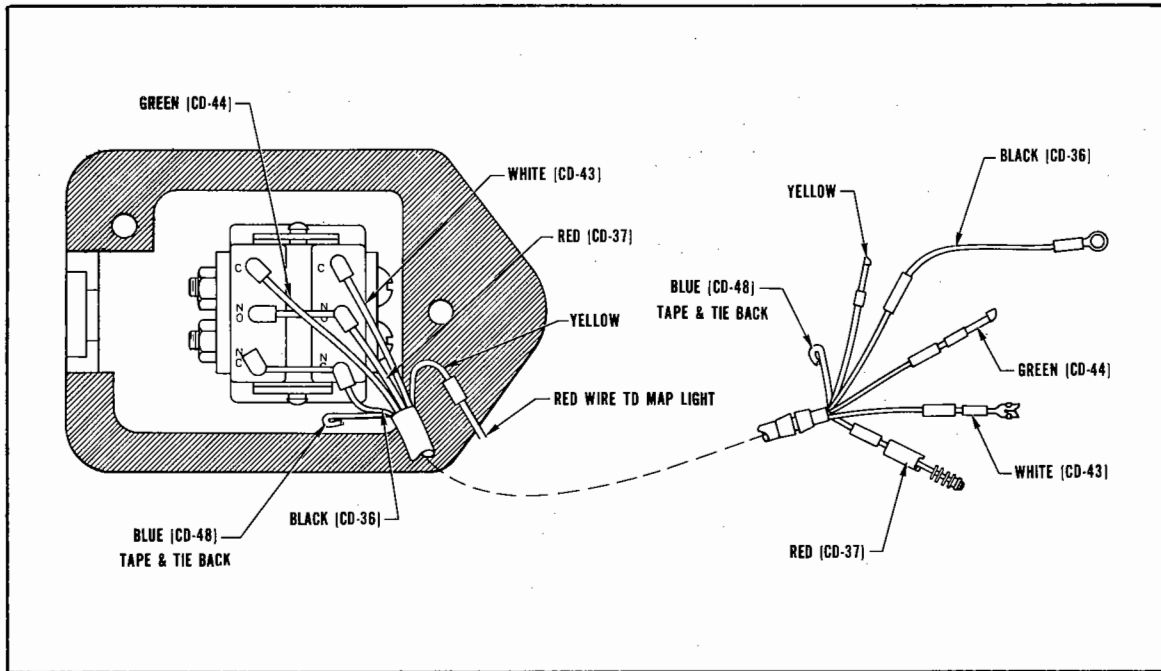

Figure 16-4. PA-24-260, PA-30, PA-39
M. E. T. - 3 Control Wheel Switch

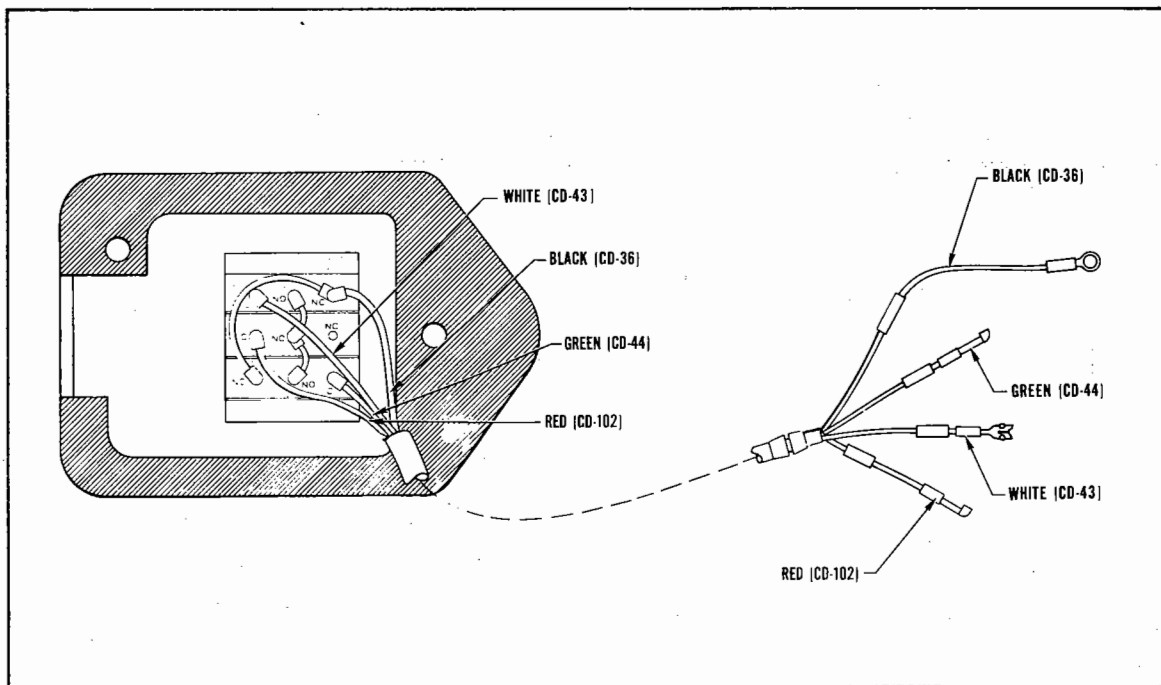

Figure 16-5. PA-34-200 and PA-34-200T
M. E. T. - 3 Control Wheel Switch

PIPER PITCH TRIM SERVICE MANUAL

16-5. GROUND CHECKS FOR M. E. T. - 3 ELECTRIC PITCH TRIM SYSTEM. This section contains the information necessary to ground check the operation of the M. E. T. - 3 Electric Pitch Trim Systems used in Piper airplanes.

NOTE

In the event the trim servo does not drive the pitch trim system, it must be determined if the malfunction is mechanical or electrical. If mechanical, refer to Clutch Adjustment Procedure, Paragraph 16-3. If electrical, refer to Section XVIII and utilize the appropriate schematic to troubleshoot the trim system.

- a. Turn the airplane master switch ON.
- b. Ascertain the trim circuit breaker and/or the panel mounted trim switch is pushed to the IN position.
- c. Place pitch trim at approximately neutral position.
- d. Move the trim switch on the pilot's control wheel (on PA-34-200 airplanes small button on top of switch must be depressed) to the FORWARD or NOSE DOWN position. The trim servo should drive the pitch trim NOSE DOWN.
- e. Release the trim switch, it will return to the center or OFF position.
- f. Move the trim switch on the pilot's control wheel (on PA-34-200 airplanes small button on top of switch must be depressed) to the AFT or NOSE UP position. The trim servo should drive the pitch trim NOSE UP.
- g. Release the trim switch it will return to the center or OFF position.
- h. Apply forward and AFT pressure on the control wheel. The trim servo should be disengaged and should not drive the pitch trim.
- i. Turn the airplane master switch OFF.

16-6. FLIGHT CHECKS OF THE M. E. T. - 3 ELECTRIC PITCH TRIM SYSTEM. This section contains the information necessary to flight check the operation of the M. E. T. - 3 Electric Pitch Trim Systems used in Piper airplanes. Hand fly the airplane to a safe cruising altitude and adjust power and trim settings for level flight in a cruise configuration.

- a. Ascertain the Trim Circuit Breaker and/or the panel mounted electric trim switch is pushed to the IN position.
- b. Move the trim switch on the pilot's control wheel (on PA-34-200 airplanes small button on top of switch must be depressed) to the FORWARD or NOSE DOWN position.
- c. The airplane should trim NOSE DOWN.
- d. Release the trim switch, it will return to the center or OFF position.
- e. The electrical power used to drive the trim servo motor will be disengaged and the airplane will continue to be trimmed NOSE DOWN until it is retrimmed to a new pitch attitude.

- f. Move the trim switch on the pilot's control wheel (on PA-34-200 airplanes small button on top of switch must be depressed) to the AFT or NOSE UP position.
- g. **The airplane should trim NOSE UP.**
- h. **Release the trim switch, it will return to the center or OFF position.**
- i. **The electrical power used to drive the trim servo motor will be disconnected and the airplane will continue to be trimmed NOSE UP until it is retrimmed to a new pitch attitude.**
- j. **If the trim system fails to react to either NOSE UP or NOSE DOWN or both, the control wheel switch and wiring should be checked to see if it is defective.**

SECTION XVII

TEST EQUIPMENT

Paragraph	Page
NOTE Test Equipment	17-1

SECTION XVII
TEST EQUIPMENT

NOTE

Because of the simplicity of the M. E. T. - 3 Electric Pitch Trim System there is no need for any special test equipment. The servo motor current drain test as outlined in Section XVI, Paragraph 16-4 with a standard ammeter (or equivalent). The remaining test for the system may be accomplished with a standard volt ohmmeter. The volt ohmmeter is utilized when obtaining the results in Table XVII-I and for continuity testing of the wiring harness, also for checking for A+ in accordance with the schematics in Section XVIII of this manual. Failure to obtain the values listed in Table XVII-I indicates a defective servo and replacement is required.

TABLE XVII-I. SERVO CONTINUITY TEST

CD-45 SERVO FEMALE CONNECTOR
PA-23-250, PA-24-260, PA-30 AND PA-39 INSTALLATIONS

Pins	Ohmmeter Leads Normal	Ohmmeter Leads Reversed
A to B	∞	∞
A to C	∞	∞
A to D	∞	∞
B to C	96	∞
B to D	96	∞
C to D	*1.5-3	*1.5-3

CD-45 SERVO FEMALE CONNECTOR
PA-34-200 and PA-34-200T INSTALLATIONS

Pins	Ohmmeter Leads Normal	Ohmmeter Leads Reversed
A to B	∞	∞
A to C	96	∞
A to D	96	∞
B to C	∞	∞
B to D	∞	∞
C to D	*1.5-3	*1.5-3

*Reading depends on Brush Tension Servo Motor. May be any amount from 1.5 to 40 ohms.

SECTION XVIII

SCHEMATICS

Paragraph	Page
18-1. Introduction	18-1

SECTION XVIII

SCHEMATICS

18-1. INTRODUCTION. This section of the manual consists of schematics of the electrical circuitry of the M. E. T. - 3 Electric Pitch Trim Systems installed in Piper airplanes. The schematic diagrams should be used as an aid in troubleshooting the electrical portion of the trim system.

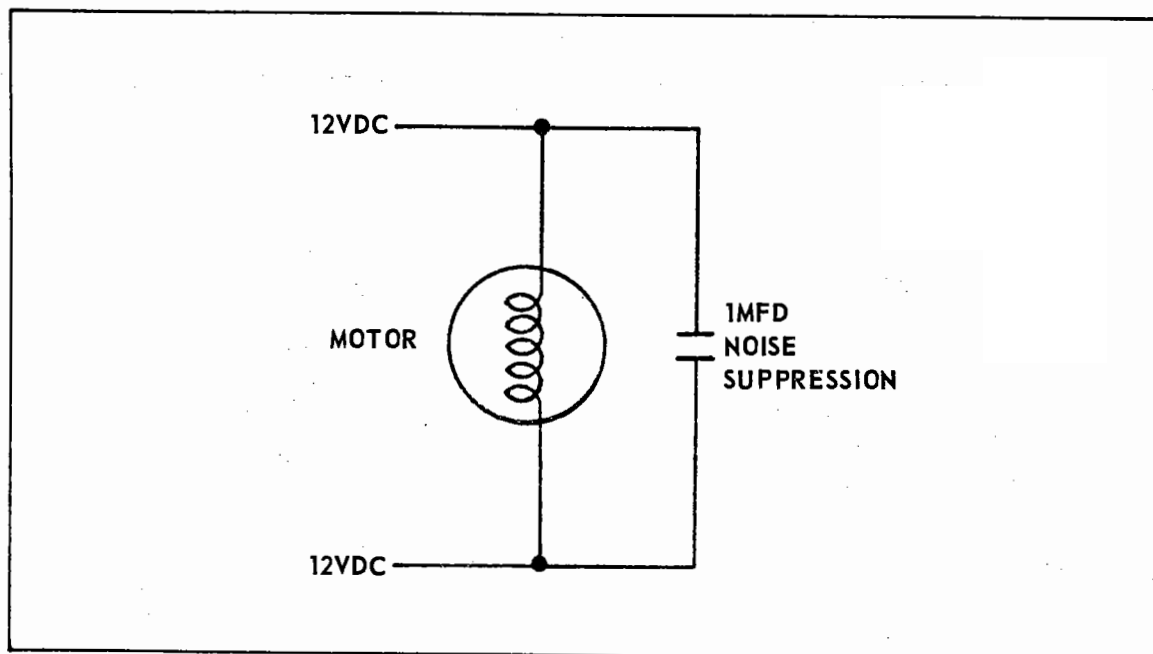

Figure 18-1. M. E. T. Series Trim Servo Motor

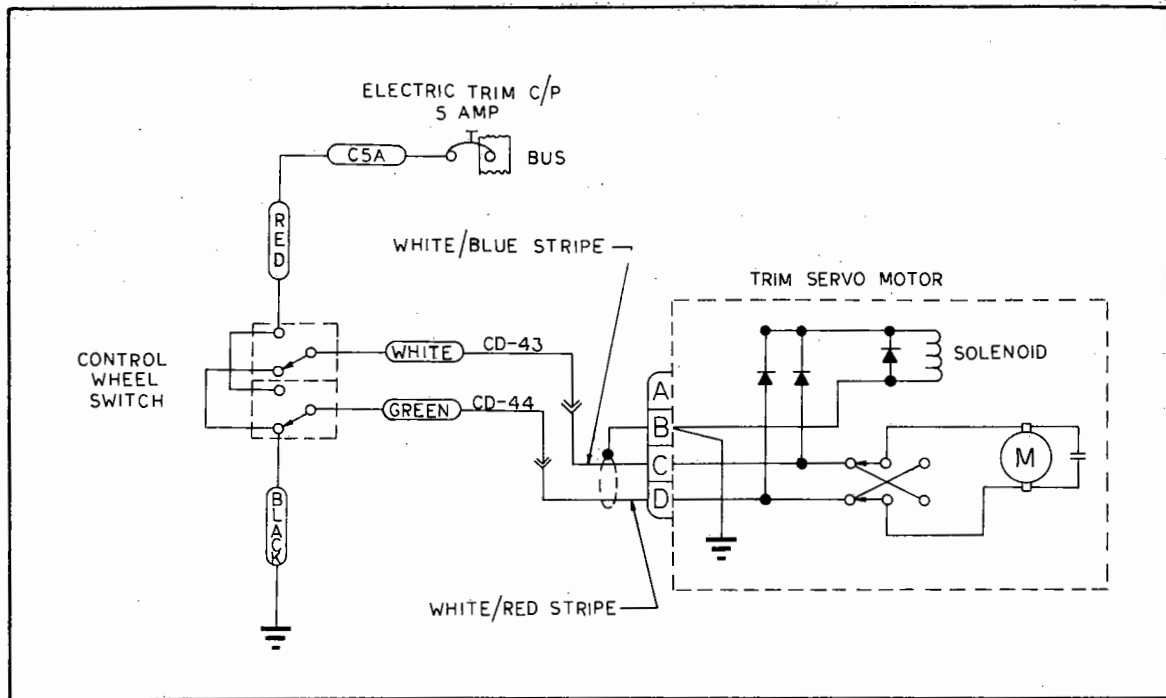

Figure 18-2. M. E. T. -3 Manual Electric Trim Schematic
PA-23-250, PA-24-260, PA-30 and PA-39

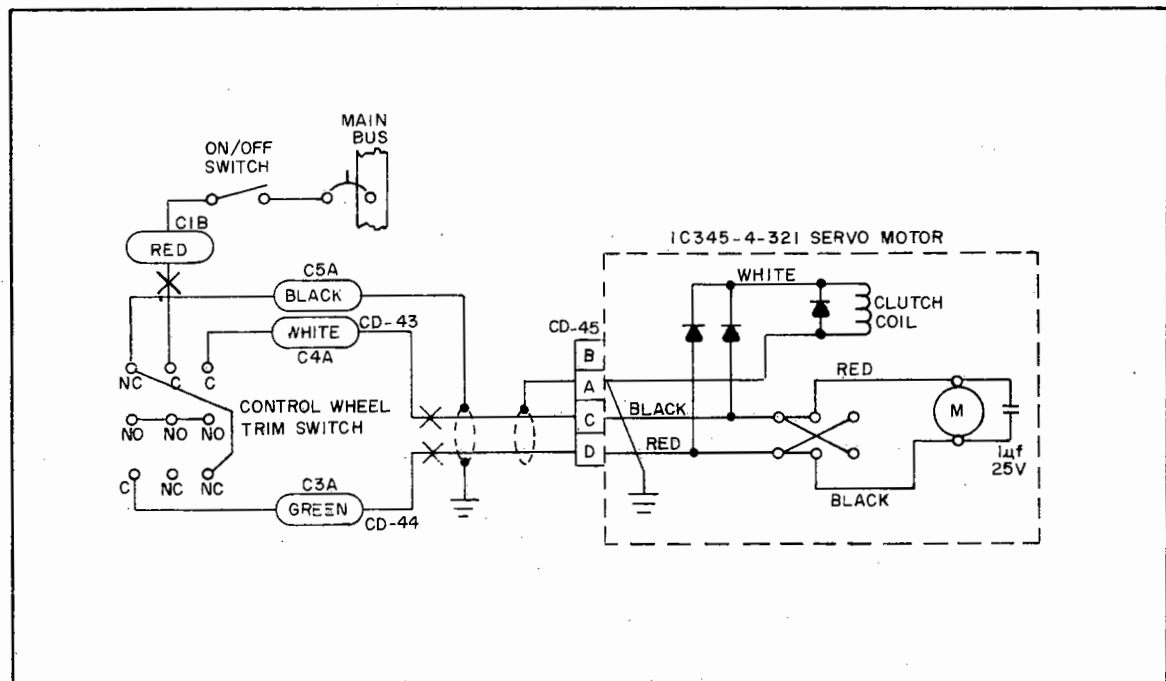

Figure 18-3. M. E. T. -3 Manual Electric Trim Schematic
PA-34-200 and PA-34-200T

PART IV

ALTIMATIC III, IIIB AND IIIB-I ELECTRIC TRIM SYSTEMS

(DUAL CONTACT TYPE TRIM SENSOR)

PA-23-250 (Six Place)

SECTION XIX

INTRODUCTION AND DESCRIPTION

Paragraph		Page
19-1.	Introduction	19-1
19-2.	Description	19-1

SECTION XIX

INTRODUCTION AND DESCRIPTION

19-1. INTRODUCTION. This part of the service manual is divided into six sections. Section XIX contains a description of the III Series Automatic Electric Pitch Trim System. Section XX, Theory of Operation, explains the modes of operation. Section XXI, Removal and Installation, provides the information necessary for removal and installation of all trim components. Section XXII, Adjustment Procedures and Operational Checks, provides the information necessary to check the operation of the system and perform minor adjustments. Section XXIII, Test Equipment, describes the test equipment required to center the trim sensor contacts. Section XXIV, Schematics, provides the schematic of the trim system for troubleshooting purposes.

19-2. DESCRIPTION. The III Series Automatic Electric Pitch Trim System is a system which trims the pitch axis of the airplane electrically. The operation of this system will be explained in Section XX. It utilizes solenoid engage and incorporates the use of a permanent magnet type motor.

SECTION XX

THEORY OF OPERATION

Paragraph		Page
20-1.	Description	20-1
20-2.	Trim Sensor Considerations	20-1

SECTION XX

THEORY OF OPERATION

20-1. DESCRIPTION. The III Series Automatic Electric Pitch Trim System (Dual contact type trim sensor) has both a manual mode and an automatic mode of operation. The manual mode is operational only when the AutoPilot is disengaged and the automatic mode is operational when the pitch axis of the AutoPilot is engaged. The switch that controls the mode of operation is the pitch engage switch located in the AltiMatic III Series Console.

A differential cable tension sensing mechanism known as a trim sensor is incorporated in the Automatic Electric Pitch Trim Systems installed in Piper airplanes. This sensor is the plate type sensor and consists of a dual set of adjustable electrical contacts which, when actuated by unequal stabilator cable tension, completes an electrical circuit in the trim amplifier. The trim amplifier converts the trim sensor signals into electrical power sufficient to drive the DC trim servo motor in the proper direction to correct an out of trim condition. The centering adjustment of the trim sensor contacts is of prime importance since the operation of the III Series Electric Pitch Trim System is dependent on the centering adjustment of the trim sensor. The reaction of the sensor contacts to both equal and unequal stabilator control cable tension is shown in illustration form, see Figure 20-1 and 20-2. A detailed procedure on dual contact type trim sensor centering is contained in Section XXI, Paragraph 21-8. When servicing any other type of III Series trim sensors, refer to Section IX of this manual for the appropriate procedure.

Stabilator control cable tension is very important for the correct operation of the trim sensor. Low cable tension can cause insensitive trim sensor action and high cable tension can cause over sensitive trim sensor action. A substantial decrease in temperature can cause a decrease in cable tension, while a substantial increase in temperature will cause an increase in cable tension. This is caused by a negative coefficient of expansion between the aluminum in the airplane structure and the steel control cables. It is recommended that temperature be considered when adjusting or checking control cable tension. To insure that the control cable tension will remain within the tolerance specification published in the appropriate Airframe Service Manual. The high portion of the control cable tension specification should be used when checking or setting the control cable tension during extremely high temperatures. The low portion of the control cable tension specification should be used when checking or setting the control cable tension during extremely low temperatures. This procedure will insure that the control cable tension will remain within the control cable tension specification for temperature variations.

20-2. TRIM SENSOR CONSIDERATIONS. The dual contact type trim sensor used with the III Series Trim System does not have an amplifier attached. The trim amplifier is installed on the trim servo and the trim sensor and amplifier are utilized ONLY in the AUTOMATIC MODE. A time delay circuit of one second is incorporated in the Automatic Mode.

a. III SERIES AUTOMATIC ELECTRIC PITCH TRIM SYSTEM (Dual Contact Type Trim Sensor) – MANUAL MODE. This mode applies to the trim system when the AutoPilot is disengaged. The disengage button is incorporated in the control-wheel-mounted trim switch and must be depressed to make the electric trim switch effective. Trim may be accomplished by the human pilot electrically by the use of the trim switch on the pilot's control wheel which is a three position switch, spring-loaded to the center or OFF position. When the trim switch is moved to the forward position with the disengage button depressed, it completes a circuit to the servo motor, supplying voltage of a proper polarity to assure rotation of the motor in the correct direction. At the same time, the switch supplies power to a solenoid which engages the trim servo motor to the capstan through a set of gears. Since the trim system cables are wrapped around the capstan, any rotation of the trim servo motor results in a change of position of the airplane's trim system, thus deflecting the stabilator trim tab in the conventional manner. When the human pilot releases the switch, it returns to the OFF position and power is then disconnected from the trim servo motor and the engage solenoid which completely disengages the electric trim motor from the airplane's trim system cables. If the switch is moved to the rear position, the same events occur except the polarity of the servo motor is reversed insuring the opposite direction of rotation.

b. III SERIES AUTOMATIC ELECTRIC PITCH TRIM SYSTEM (Dual Contact Type Trim Sensor) – AUTOMATIC MODE. When the Roll and Pitch engage switches on the AltiMatic III Series Console are engaged, the trim switch on the pilot's control wheel becomes inoperative and electrical power is applied to the trim amplifier and pitch trim servo engage solenoid through the servo console pitch engage switch. When the trim sensor detects a differential in stabilator cable tension caused by an out of trim condition, the "trim sensor" mechanically actuates a dual set of electrical contacts. These contacts complete an electrical circuit in the trim amplifier which converts the trim sensor signals into electrical power sufficient to drive the DC trim servo motor.

NOTE

The engage solenoid will maintain engagement of the servo motor and capstan gears continuously while the pitch axis of the AutoPilot is engaged.

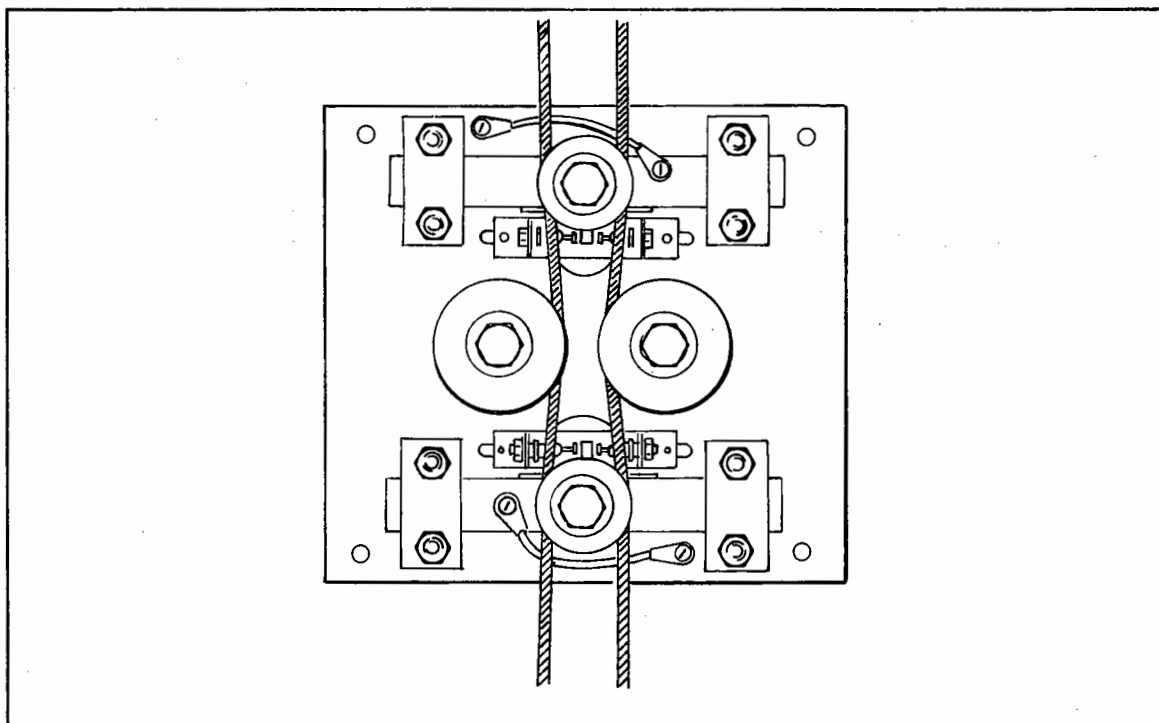

Figure 20-1. Plate Sensor (Dual Contact) Equal Stabilator Cable Tension

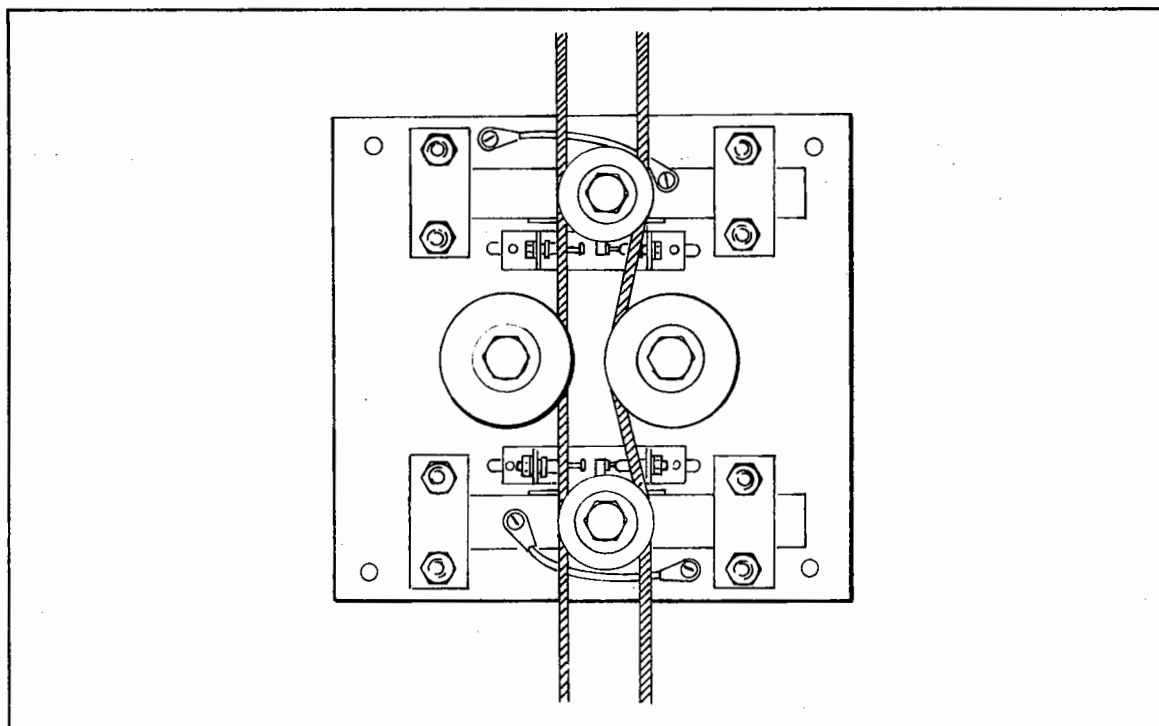
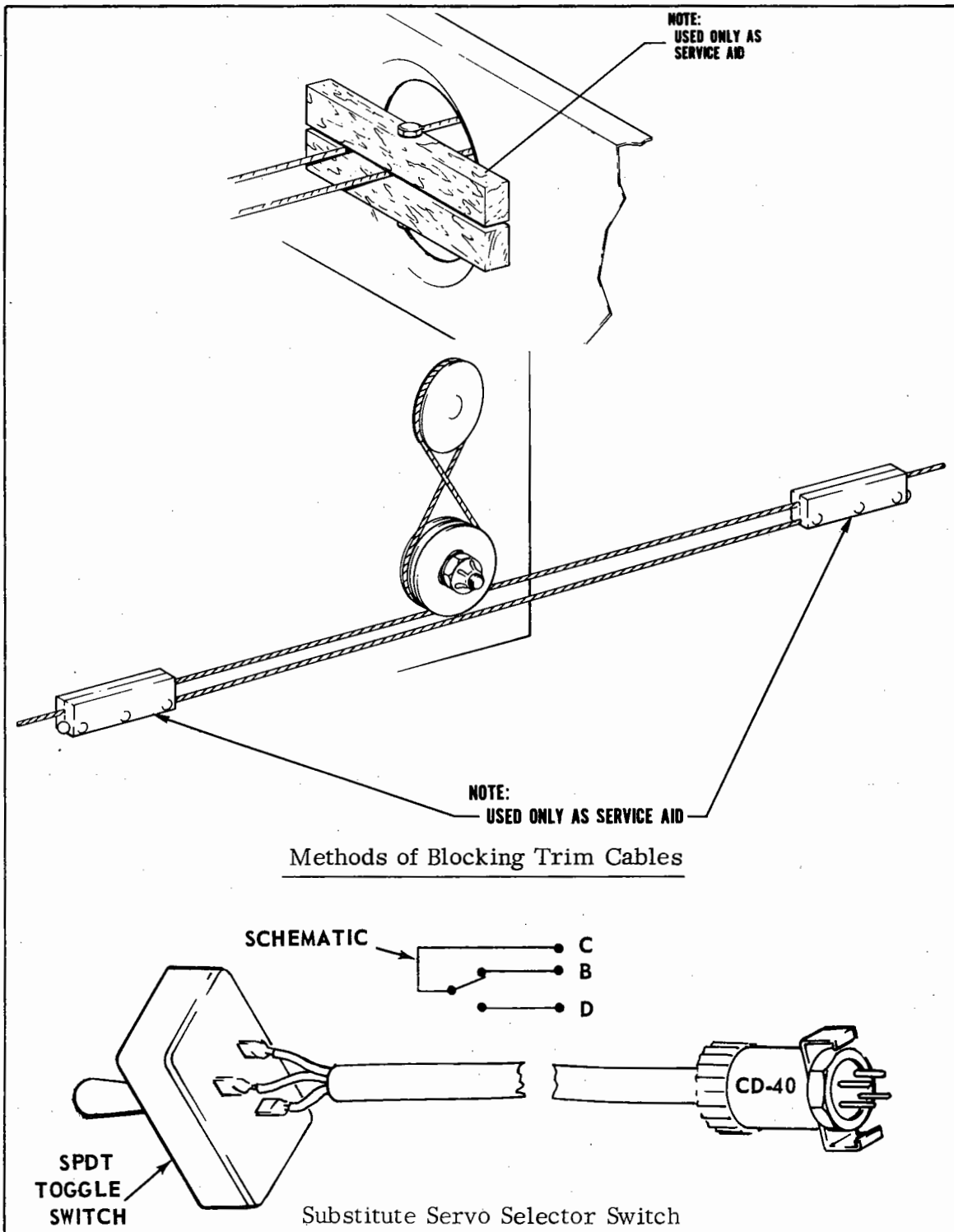

Figure 20-2. Plate Sensor (Dual Contact) Unequal Stabilator Cable Tension

SECTION XXI

REMOVAL AND INSTALLATION

Paragraph		Page
21-1.	Introduction	21-3
21-2.	Removal of Trim Servo - PA-23-250 (Six Place)	21-3
21-3.	Installation of Trim Servo - PA-23-250 (Six Place)	21-3
21-4.	Removal of Trim Amplifier on 1C345-5 and/or 1C469-5 Trim Servo - PA-23-250 (Six Place)	21-4
21-5.	Installation of Trim Amplifier on 1C345-5 and/or 1C469-5 Trim Servo - PA-23-250 (Six Place)	21-4
21-6.	Removal of Trim Sensor - PA-23-250 (Six Place)	21-4
21-7.	Installation of Trim Sensor - PA-23-250 (Six Place)	21-4
21-8.	Dual Contact Trim Sensor Centering Procedures	21-6



Methods of Blocking Trim Cables

Substitute Servo Selector Switch

Figure 21-1. Servicing Aids

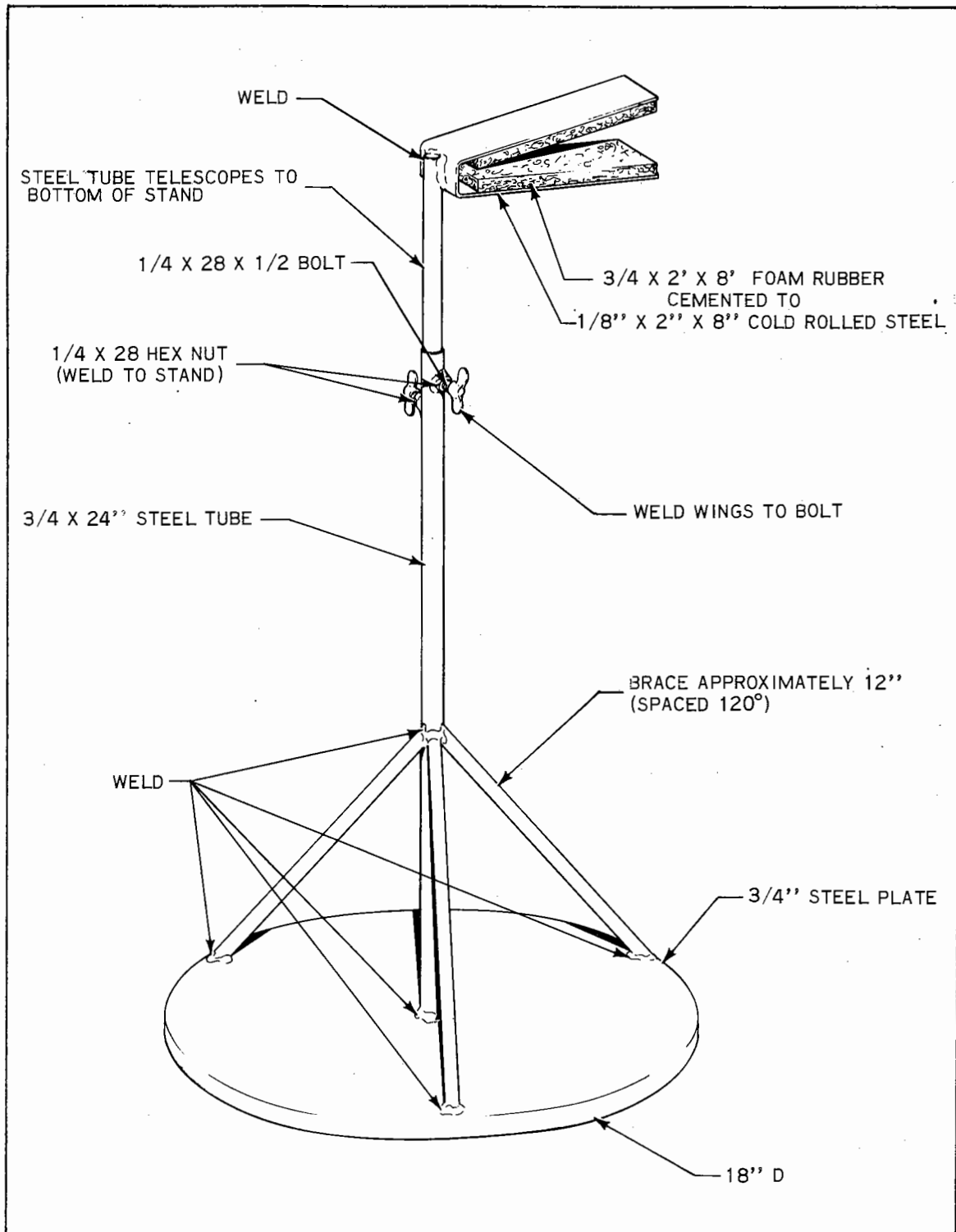

Figure 21-2. Typical Stabilator Holding Fixture

SECTION XXI

REMOVAL AND INSTALLATION

21-1. INTRODUCTION. The information in this section describes the procedures for removal and installation of the components of the III Series Automatic Electric Pitch Trim System (Dual contact type trim sensor) used in Piper airplanes. Included with the installation procedures are the necessary set-up and adjustment instructions. When any component of the trim system is installed, a complete functional check of the entire trim system must be made to confirm correct system operation. When using this section refer to the type of component to be removed or installed. Refer to Paragraph 21-8 for Dual Contact Trim Sensor Centering Procedures. To maintain cable routing of the trim cable during removal and installation of trim servos, it is recommended that the service aids shown in Figure 21-1 be utilized. Service aids as shown can be fabricated locally from shop material. If in doubt about the operation of the servo selector switch, the locally fabricated servo selector switch may be substituted by connecting it to the CD-40 plug on the console.

21-2. REMOVAL OF TRIM SERVO. PA-23-250 (Six Place).

The trim servo is located in the top aft baggage compartment.

- a. Access to the servo is through the aft baggage compartment door.
- b. Remove the box type trim panel forward of the baggage compartment dome light by removing six attaching screws.
- c. Remove the baggage area rear panel to gain access to the cable turnbuckles to release the tension on the cables.
- d. Disconnect electrical connections from the servo assembly.
- e. Remove four mounting bolts securing the servo assembly to the mounting brackets.
- f. Unwrap trim cable from capstan and idler pulley and remove servo assembly from the airplane.

21-3 INSTALLATION OF TRIM SERVO. PA-23-250 (Six Place). (Refer to Figure 21-3.)

- a. Position trim servo on the mounting brackets and secure with mounting bolts.
- b. Route the trim cable from the forward part of the airplane around the top capstan groove to the idler pulley and around the bottom capstan groove to the aft section of the airplane, completing a figure eight.
- c. Tighten the trim cable (on aircraft incorporating the Stabilator Bungee Spring Installation, the Bungee Spring must be disconnected when adjusting cable tension) to obtain the appropriate tension as listed in Table XXI-I.
- d. Connect electrical connections to trim servo assembly and check servo operation.
- e. Install baggage area rear panel and secure with attaching screws.
- f. Install box type trim panel forward of baggage compartment dome light and secure with attaching screws.

21-4. REMOVAL OF TRIM AMPLIFIER ON 1C345-5 AND/OR 1C469-5 TRIM SERVO. PA-23-250 (Six Place).

The trim amplifier is located on the trim servo mounting plate in the top aft baggage compartment.

- a. Access to the trim amplifier is through the aft baggage compartment door.
- b. Remove the metal screws securing the headliner in the baggage compartment and remove headliner.
- c. Disconnect CD-45 and CD-101 electrical connections from the trim amplifier.
- d. Disconnect CD-73 electrical connection from trim servo.
- e. Remove the two screws securing the trim amplifier to trim servo mounting plate.
- f. Remove the trim amplifier from the airplane.

21-5. INSTALLATION OF TRIM AMPLIFIER ON 1C345-5 AND/OR 1C469-5 TRIM SERVO. PA-23-250 (Six Place). (Refer to Figure 21-3.)

- a. Position the trim amplifier on the trim servo mounting plate and secure with appropriate screws.
- b. Connect the CD-45 and CD-101 electrical connections to trim amplifier.
- c. Connect the CD-73 electrical connection to trim servo and check servo operation.
- d. Install headliner in baggage compartment and secure with appropriate screws.

21-6. REMOVAL OF TRIM SENSOR. PA-23-250 (Six Place). The trim sensor is located on a mounting bracket under the main spar of the airplane.

- a. Remove the bottom fuselage panel aft of the nose gear doors by removing screws securing panel.
- b. Cables on sensor can be removed by applying pressure to both cables and moving the cables out of trim sensor pulley grooves. If desired, the stabilator cable may be loosened to facilitate removing from the sensor.
- c. Disconnect the CD-41 and CD-100 electrical connections.
- d. Remove the nuts and bolts securing the trim sensor to the mounting brackets.
- e. Remove the trim sensor from the airplane.

21-7. INSTALLATION OF TRIM SENSOR. PA-23-250 (Six Place). (Refer to Figure 21-4.)

- a. With the trim sensor pulleys facing up, route the stabilator control cables through the trim sensor pulleys. The trim sensor will center itself on the stabilator control cables.
- b. Position the trim sensor on the mounting brackets and secure with appropriate nuts and bolts.
- c. Check stabilator control cables for proper tension as listed in Table XXI-II.

NOTE

The outboard pulleys on the trim sensor must have freedom of rotation and vertical movement from their normal position when the trim sensor is properly aligned with the stabilator control cables.

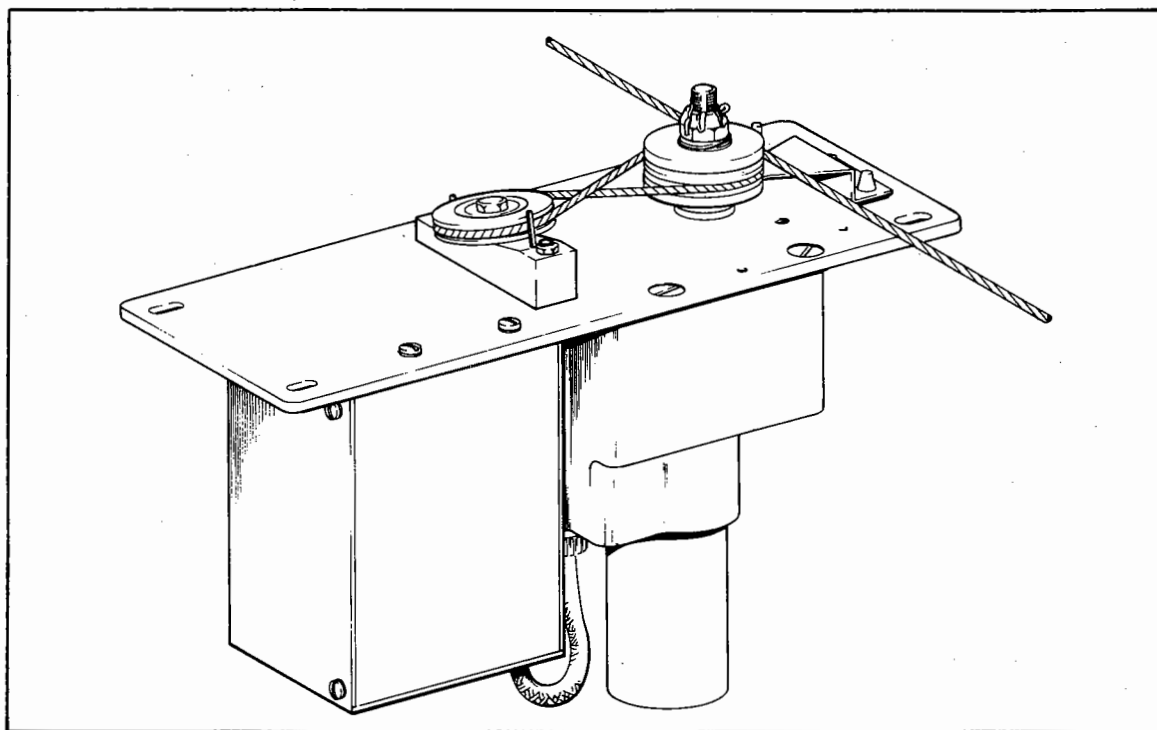

Figure 21-3. PA-23-250 Trim Servo Cable Routing

TABLE XXI-I. TRIM SERVO CABLE TENSION

AIRPLANE	CABLE	CABLE TENSION
PA-23-250	Stabilator Trim	15 ± 20% (3 lbs.)

TABLE XXI-II. TRIM SENSOR CABLE TENSION

AIRPLANE	CABLE	CABLE TENSION
PA-23-250	Stabilator	35 lbs. ± 10% (3.5 lbs.)

- d. Refer to Paragraph 21-8 for dual contact trim sensor centering instructions.
- e. Connect the CD-41 and CD-100 electrical connections and perform the ground operational check of the Pitch Trim System as outlined in Section XXII, Paragraph 22-4.
- f. Install bottom fuselage panel previously removed and secure with appropriate screws.

21-8. DUAL CONTACT TRIM SENSOR CENTERING PROCEDURES. The dual contact type trim sensor incorporated with the III Series Automatic Pitch Trim Systems is shown in illustration form in this section of the manual, refer to Figure 21-5. When making dual contact centering adjustments, it is very important to follow the detailed instructions to avoid damage to the test equipment and the sensor.

a. The following listed test equipment must be used to adjust the trim sensor centering contacts.

- 1. Output Meter (66B83-1)
- 2. Output Meter Cable (30A177)
- 3. Output Meter Adapter Cable (66A119)
- 4. Output Meter Adapter Cable (66A305)
- 5. Feeler Gauge (Standard)

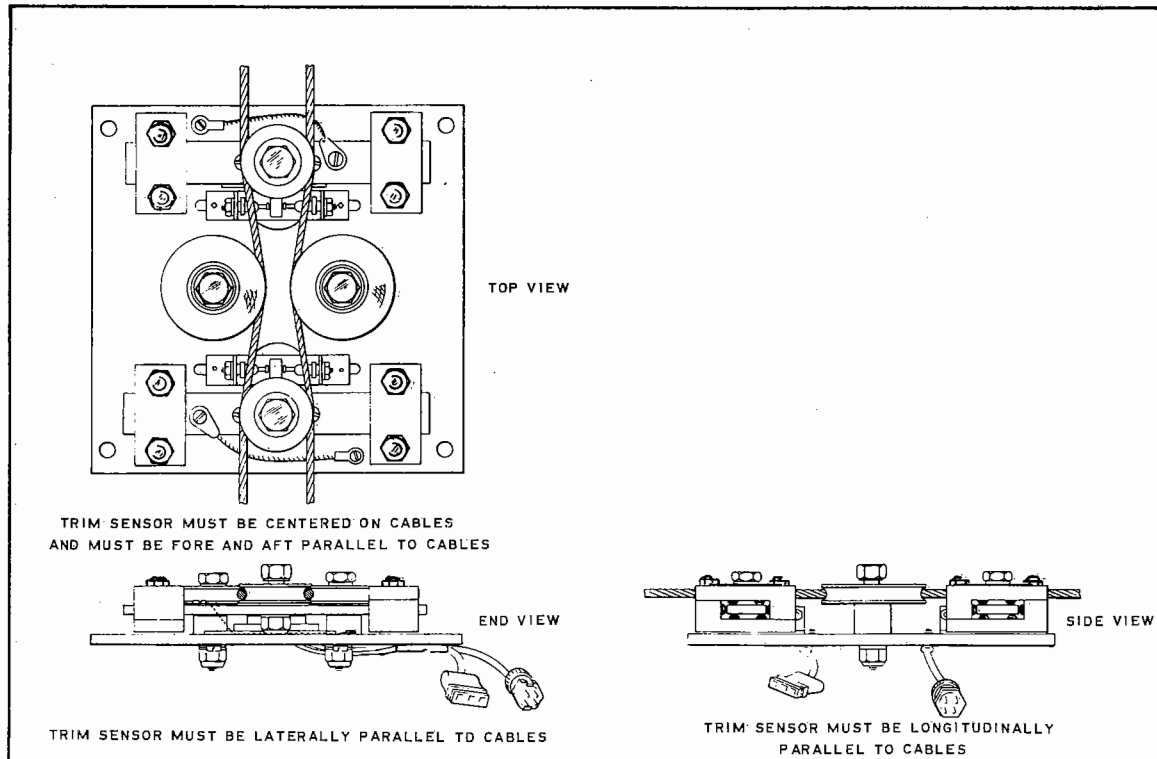

Figure 21-4. PA-23-250 Dual Contact Type Trim Sensor

CAUTION

When using the 66B83-1 Output Meter on airplanes incorporating a 24-volt system, it is necessary that an external 12-volt power source be used to avoid damage to the Output Meter.

- b. Support the stabilator in approximate level flight position before proceeding with the dual contact trim sensor centering.

NOTE

The stabilator should be firmly supported at its trailing edge. Place support on stabilator, not on trim tab. Do not attempt to hold stabilator in position as it is impossible to hand hold the stabilator steady enough to accomplish the correct adjustment. A typical stabilator holding fixture is shown in Figure 21-2. Such a fixture should be used in conjunction with a jack placed under the tail skid.

- c. Centering procedure for plate type dual contact trim sensor. (Refer to Figure 21-5.)
 1. Turn OFF airplane master switch.

CAUTION

Whenever a trim sensor without an amplifier mounted on the sensor is being adjusted by use of the Output Meter, it is necessary to use the 66A119 and/or the 66A305 adapter cables. If the adapter cables are not used, the Output Meter or cable may be damaged by a direct short. The Output Meter will become warm after a few minutes use due to the internal resistive load of the meter and should in no way be mistaken for a defective meter as this is normal operation.

2. Ascertain the total point gap setting is correct prior to adjusting the dual contact type trim sensor. This may be accomplished by utilizing the following procedure.
 - a. Apply pressure to one side of slide bar containing contact block, forcing one side of contact points closed.
 - b. Using a standard feeler gauge, measure resulting point gap.
 - c. Point gap setting should be $.007 \pm .002$.

- d. If point gap setting is out of tolerance replace trim sensor.
- e. Reaccomplish steps a thru d for the remaining set of contact points.
3. Connect the end of cable 30A177 with the clip lead to the Output Meter.
4. Connect the remaining end of cable 30A177 to the female end of adapter 66A119.
5. Connect the male end of adapter cable 66A119 to the CD-41 lead on the trim sensor.
6. Connect the alligator clip of cable 30A177 to a 12-volt positive source.
7. Connect the alligator clip of adapter cable 66A119 to the negative side of the 12-volt source.
8. Make sure the sensor pulleys are parallel to the stabilator cables and the stabilator is blocked to approximately level flight.
9. Turn on 12-volt source.
10. If Output Meter indicates zero output, the contacts are centered proceed to step 11. If not, proceed with the following steps:
 - a. Loosen set screws of adjustment bracket assembly #1 so bracket assembly moves with some friction. (Refer to Figure 21-5.)
 - b. Move adjustment bracket assembly #1 as required to obtain zero output on the meter.
 - c. Tighten adjustment screws on bracket assembly #1 and turn off 12-volt source.
11. Disconnect adapter cable 66A119 from trim sensor lead CD-41.

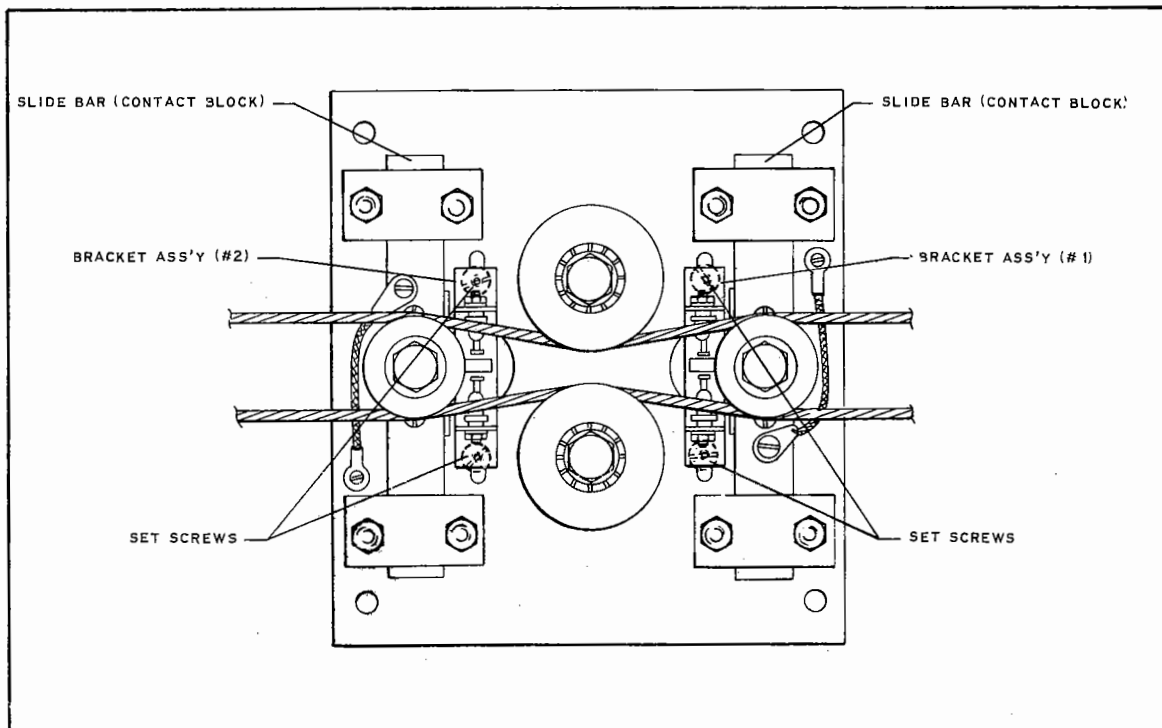

Figure 21-5. Dual Contact Type Trim Sensor

12. Disconnect the remaining end of adapter cable 66A119 from output meter cable 30A177, also the alligator clip of adapter cable 66A119 from the negative side of 12-volt source.

13. Connect the female end of adapter cable 66A305 to cable 30A177 which is still connected to the Output Meter.

14. Connect the remaining end of adapter cable 66A305 with the clip lead to the CD-100 lead on the trim sensor.

15. Connect the alligator clip of adapter cable 66A305 to the negative side of the 12-volt source.

16. Turn on the 12-volt source.

17. If Output Meter indicates zero output, the contacts are centered proceed to step 18. If not, proceed with the following steps:

- a. Loosen set screws of adjustment bracket assembly #2 so bracket assembly moves with some friction.
- b. Move adjustment bracket assembly #2 as required to obtain zero output on the meter.
- c. Tighten adjustment screws on bracket assembly #2 and turn off 12-volt source.

18. This completes the dual contact trim sensor adjustment.

19. Disconnect Output Meter and associated cables.

20. Connect the CD-41 and CD-100 electrical connections to the trim sensor.

SECTION XXII

ADJUSTMENT PROCEDURE AND OPERATIONAL CHECKS

Paragraph		Page
22-1.	Description	22-1
22-2.	Control Wheel Harness Connections	22-1
22-3.	III Series Trim Servo Clutch Adjustment Procedure	22-1
22-4.	Ground Checks for III Series Automatic Electric Pitch Trim System (Dual Contact Type Trim Sensor)	22-2
22-5.	Flight Checks of the III Series Automatic Electric Pitch Trim System (Dual Contact Type Trim Sensor)	22-5

SECTION XXII

ADJUSTMENT PROCEDURE AND OPERATIONAL CHECKS

22-1. DESCRIPTION. This section provides the information necessary to properly adjust and perform operational checks of the III Series Electric Pitch Trim Systems. The first part of this section is comprised of servo adjustments and wiring connections for the control wheel trim switch. The second part consists of operational checks of the III Series Electric Pitch Trim System.

Complete dual contact trim sensor adjustment procedures are described in Section XXI, Removal and Installation. Information pertaining to trim sensor adjustment can be obtained by referring to the particular sensor installation.

22-2. CONTROL WHEEL HARNESS CONNECTIONS.

The pitch trim switch is mounted in the control wheel and is electrically connected to the components of the trim system through a coiled harness assembly. The connections for this installation is shown in illustration form in this section. When replacing a defective switch, refer to Figure 22-3 for the proper wiring connections on the trim switch.

22-3. III SERIES TRIM SERVO CLUTCH ADJUSTMENT PROCEDURE.

NOTE

This adjustment procedure requires two servicemen.

- a. Attach a 0-50 lb. spring scale to the trim tab cable which is attached to the trim servo. (Refer to Figure 22-1.)
- b. Turn the airplane master switch on.
- c. Using pilot's trim switch, with autopilot disengage button depressed actuate trim system in direction away from scale.
- d. Hold scale steady and note reading at which clutch slips. Clutch tolerance is listed in Table XXII-I.
- e. To adjust clutch, refer to Figure 22-2 and proceed as follows:
 1. Remove the cotter pin item #1 from the clutch tension nut.
 2. Rotate the clutch tension nut item #2 in the desired direction to obtain specified setting.

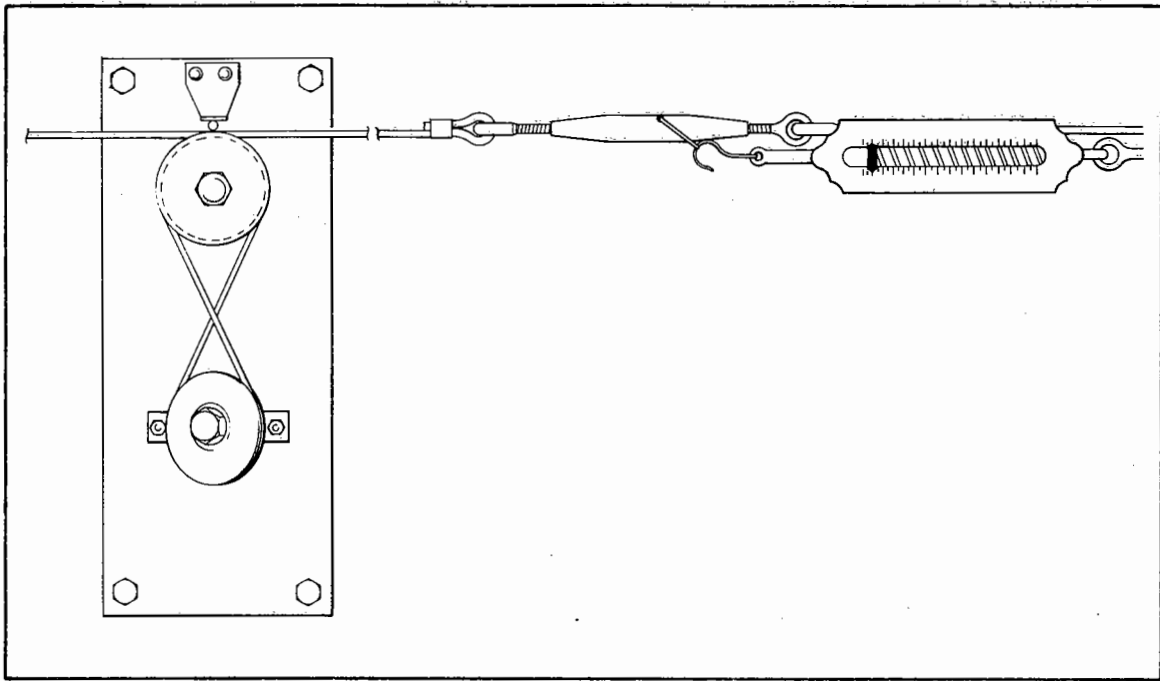

Figure 22-1. III Series Trim Servo Clutch Adjustment

NOTE

Clockwise rotation of the nut increases clutch tension. Counterclockwise rotation of the nut decreases clutch tension. There are two holes drilled through the capstan shaft. One-half castellation movement of the nut will change the tension approximately five pounds.

22-4. GROUND CHECKS FOR III SERIES AUTOMATIC ELECTRIC PITCH TRIM SYSTEM. (DUAL CONTACT TYPE TRIM SENSOR.)

This section contains the information necessary to ground check the operation of the III Series Electric Pitch Trim Systems used in Piper airplanes. The following listed checks are accomplished with the airplane master switch on and the trim circuit breaker pushed in. A schematic of the electrical circuits of the III Series Electric Pitch Trim System (dual contact type trim sensor) is located in Section XXIV of this manual.

TABLE XXII-I. III SERIES TRIM SERVO CLUTCH TENSION

AIRPLANE	SERVO NO.	CLUTCH SETTING
PA-23-250 (14-volt)	1C345-5	25 ± 5 lbs.
PA-23-250 (28-volt)	1C469-5	25 ± 5 lbs.

NOTE

In the event the trim servo does not drive the pitch trim system, it must be determined if the malfunction is mechanical or electrical. If mechanical malfunction, refer to Clutch Adjustment Procedure, Paragraph 22-3. If electrical, refer to Section XXIV and utilize the schematic to troubleshoot the trim system.

a. III SERIES AUTOMATIC ELECTRIC PITCH TRIM SYSTEM. (Dual contact type trim sensor) - MANUAL MODE.

1. Place the pitch trim at approximately neutral position.
2. Push the AltiMatic III Series Roll Engage Switch and the Pitch engage button to the out or OFF position.
3. With the A/P disengage button depressed, push the trim switch to the NOSE DOWN position. The trim servo should drive the pitch trim NOSE DOWN.
4. With the A/P disengage button still depressed, push the trim switch to the NOSE UP position. The trim servo should drive the pitch trim NOSE UP.
5. With the trim switch in the neutral or OFF position, apply FORWARD and AFT pressure on the control wheel. The trim servo should not drive the pitch trim.

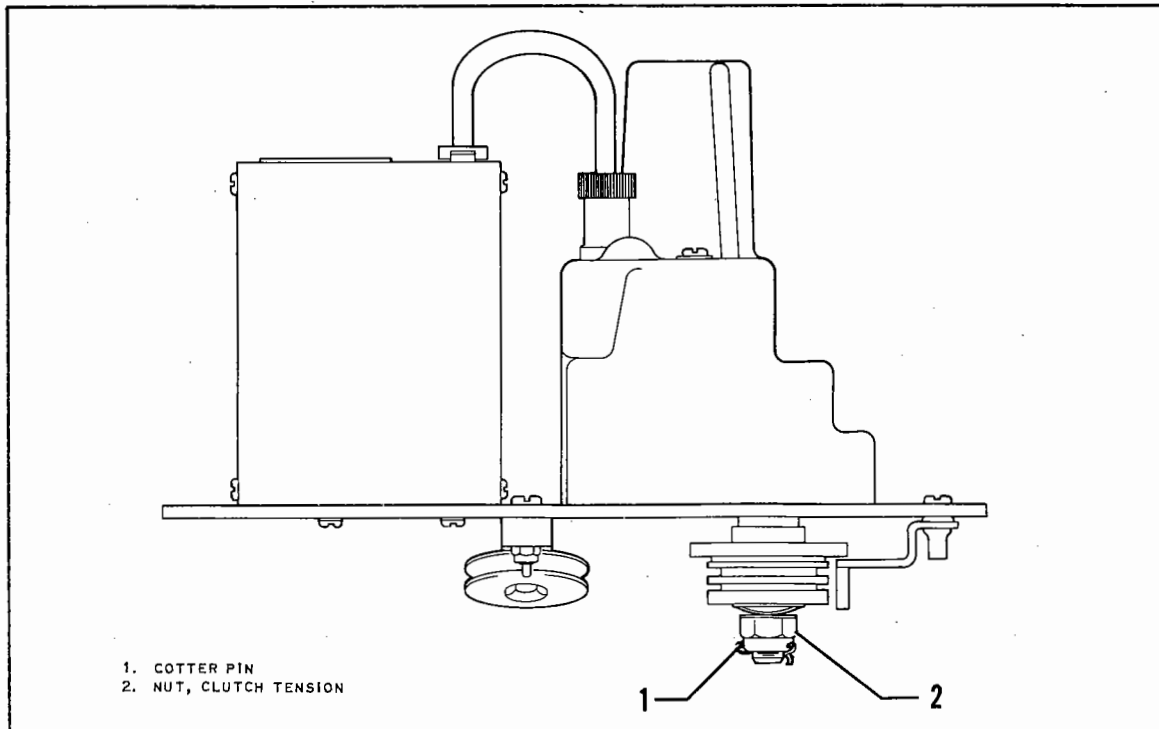

Figure 22-2. Clutch Adjustment Detail

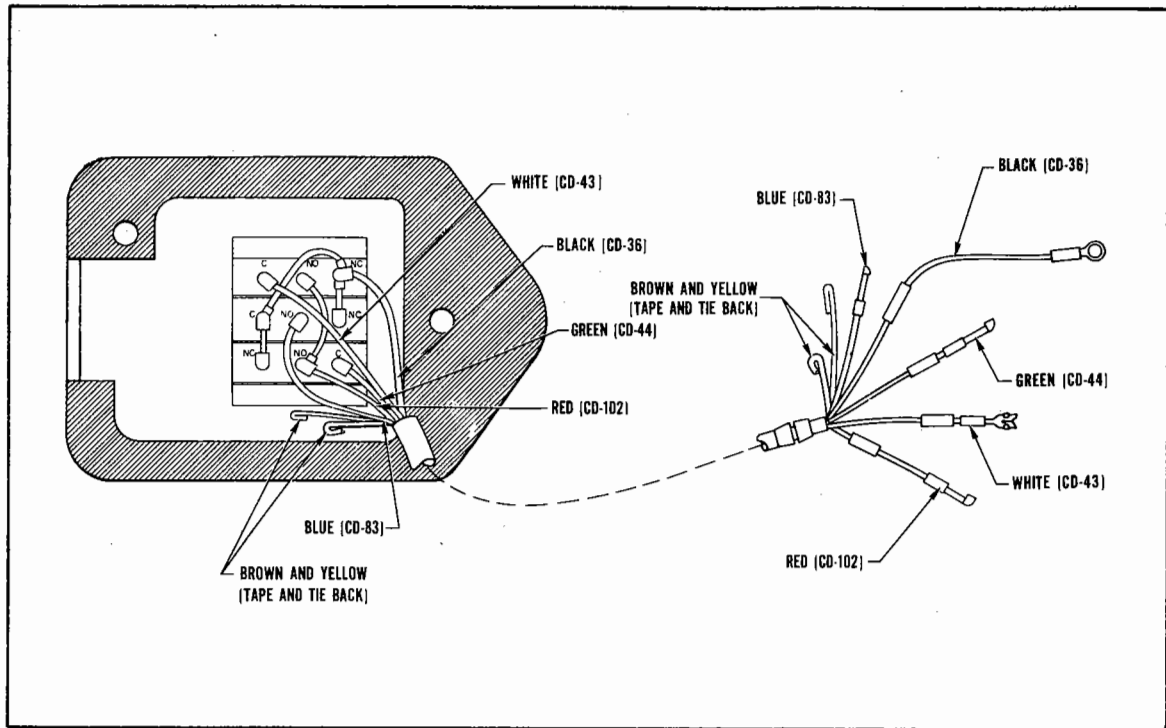

Figure 22-3. PA-23-250 AltiMatic III B-1

b. III SERIES AUTOMATIC ELECTRIC PITCH TRIM SYSTEM. (Dual contact type trim sensor) - AUTOMATIC MODE.

1. Place the pitch at approximately neutral position.
2. Push the AltiMatic III Series Roll Engage Switch and the Pitch engage button to the in or ON position.

NOTE

With the AltiMatic III Series Roll Engage Switch and Pitch engage button in the ON position, the pitch trim crank or wheel should rotate with noticeable resistance which will confirm that the servo selector switch has switched the electric trim to the automatic mode. The engage solenoid will be energized whenever the electric pitch trim is in the automatic mode.

3. Rotate the trim crank or wheel to check that the servo clutch has adequate torque. If the clutch torque is low, refer to Paragraph 22-3 for the trim servo clutch adjustment procedure.

4. Apply FORWARD and AFT movement to the trim switch. The trim switch should be inoperative.

5. Apply FORWARD pressure on the control wheel. The trim servo should drive the pitch trim NOSE DOWN.

6. Release the FORWARD pressure on the control wheel. The trim servo may either STOP or continue driving the pitch trim NOSE DOWN.

7. Apply AFT pressure on the control wheel. The trim servo should drive the pitch trim NOSE UP.

8. Release the AFT pressure on the control wheel. The trim servo may either stop or continue driving the pitch trim NOSE UP.

NOTE

If the trim servo reverses direction when the forward or aft pressure on the control wheel is released, the centering of the trim sensor contacts should be checked. Refer to Section XXI, Paragraph 21-8 for the dual contact trim sensor centering instructions.

9. Push the Roll Engage Switch and the Pitch engage button to the out or OFF position.

22-5. FLIGHT CHECKS OF THE III SERIES AUTOMATIC ELECTRIC PITCH TRIM SYSTEM. (Dual contact type trim sensor).

This section contains the information necessary to flight check the operation of the III Series Automatic Electric Pitch Trim System used in Piper airplanes.

a. III SERIES AUTOMATIC ELECTRIC PITCH TRIM SYSTEM (Dual contact type trim sensor) - MANUAL MODE.

1. Disengage the AutoPilot.

2. With the A/P disengage button depressed, move the trim switch on the pilot's control wheel to the FORWARD or nose down position.

3. The airplane should trim NOSE DOWN.

4. Release the trim switch, it will return to the center or OFF position.

5. The electrical power used to drive the trim servo motor will be disconnected and the airplane will continue to be trimmed NOSE DOWN until it is retrimmed to a new pitch attitude.

6. With the A/P disengage button depressed, move the trim switch on the pilot's control wheel to the AFT or NOSE UP position.

7. The airplane should trim NOSE UP.

8. Release the trim switch, it will return to the center or OFF position.

9. The electrical power used to drive the trim servo motor will be disconnected and the airplane will continue to be trimmed NOSE UP until it is retrimmed to a new pitch attitude.

10. If the trim system fails to react to either NOSE UP or NOSE DOWN, check that the trim circuit breaker is pushed IN. If the pitch trim still does not operate, the control wheel switch and wiring should be checked to see if it is defective.

b. III SERIES AUTOMATIC ELECTRIC PITCH TRIM SYSTEM (Dual contact type trim sensor) - AUTOMATIC MODE.

1. Engage the Roll and Pitch axis of the AutoPilot.
2. The Automatic Pitch Trim will at all times keep the airplane trimmed for any attitude of the AutoPilot.
3. When the AltiMatic III pitch axis is disengaged the airplane should be trimmed to the attitude at the time of AutoPilot disengagement. If an out of trim condition exists at the time of AutoPilot disengagement, the trim sensor centering procedure in Section XXI, Paragraph 21-8 should be checked.

NOTE

When engaging the AutoPilot, observe the trim crank. If the trim crank turns in either direction in excess of 1/3 of a complete turn, check the trim sensor centering in Section XXI, Paragraph 21-8.

SECTION XXIII

TEST EQUIPMENT

Paragraph		Page
23-1.	Introduction	23-1

SECTION XXIII

TEST EQUIPMENT

23-1. INTRODUCTION - 66B83-1 OUTPUT METER. (Refer to Figure 23-1.)

a. The 66B83-1 Output Meter is used in conjunction with Output Cable 30A177 and Adapter Cable

b. This meter is used for the following purposes and can be used for various tests, not limited to what is given in this description.

1. Finding the "center" of the contact points on the trim sensor.

2. Checking for trim sensor switch operation in both directions.

The meter incorporates a dummy load and can be read direct. The Output Meter consists of a center reading meter and an Alden receptacle to be used in conjunction with the Output Cable 30A177. Refer to the trim sensor centering instructions in Section XXI, Paragraph 21-8 for the instructions on the use of the Output Meter and cables.

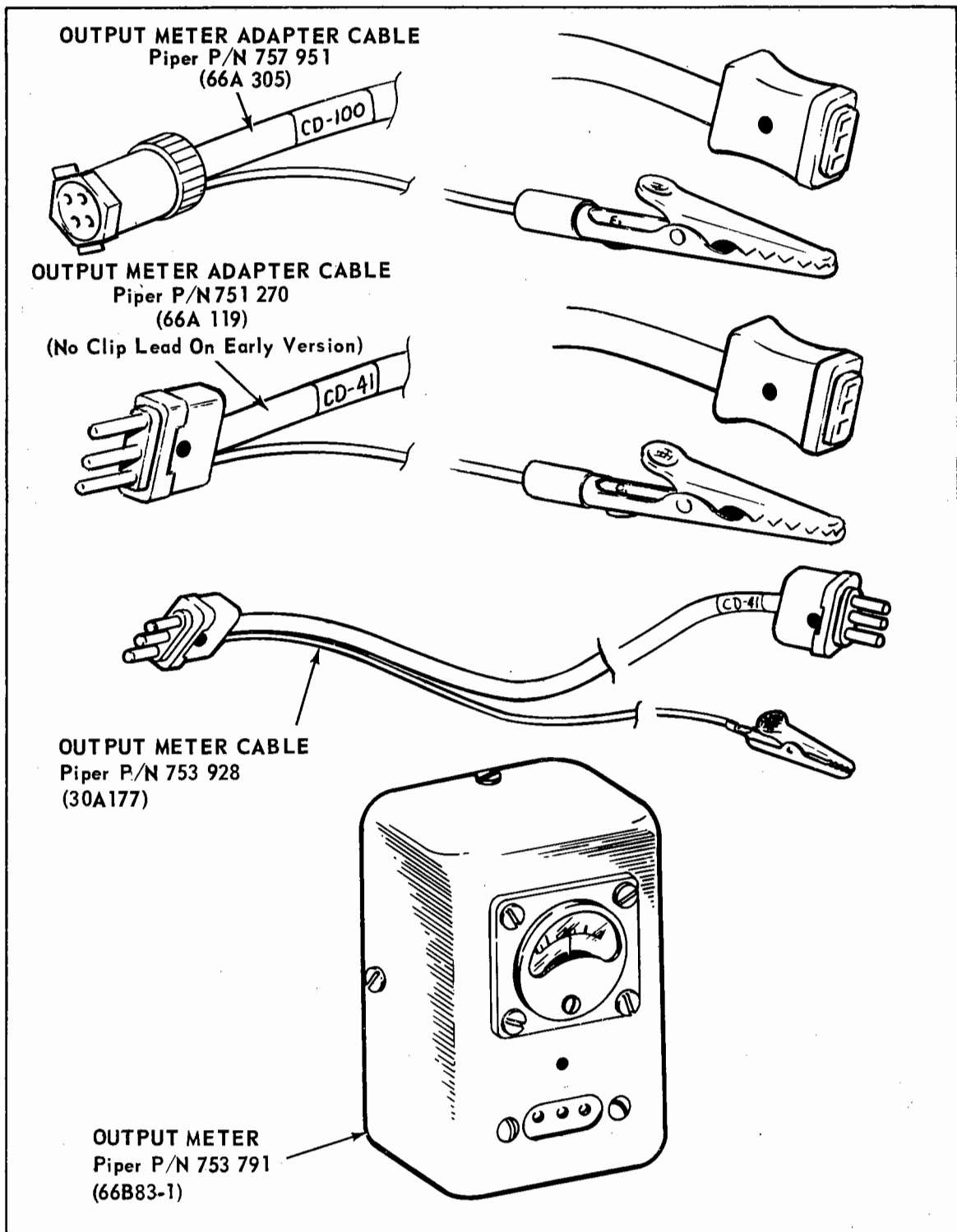

Figure 23-1. Test Equipment

SECTION XXIV

SCHEMATICS

Paragraph		Page
24-1.	Introduction	24-1

SECTION XXIV

SCHEMATICS

24-1. INTRODUCTION. This section of the manual consists of schematic diagrams of the electrical circuitry of the III Series Automatic Electric Pitch Trim System (dual contact type trim sensor) installed in Piper airplanes. The schematic diagrams should be used as an aid in troubleshooting the electrical portion of the trim system.

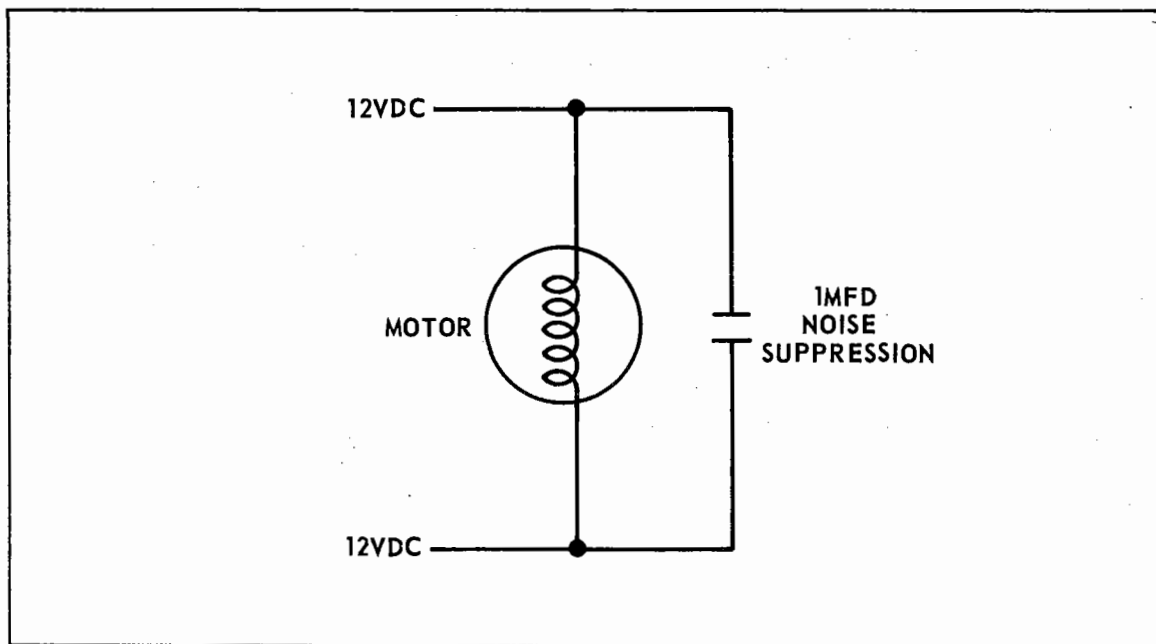

Figure 24-1. III Series Automatic Pitch Trim Servo Motor

THIS PAGE INTENTIONALLY LEFT BLANK

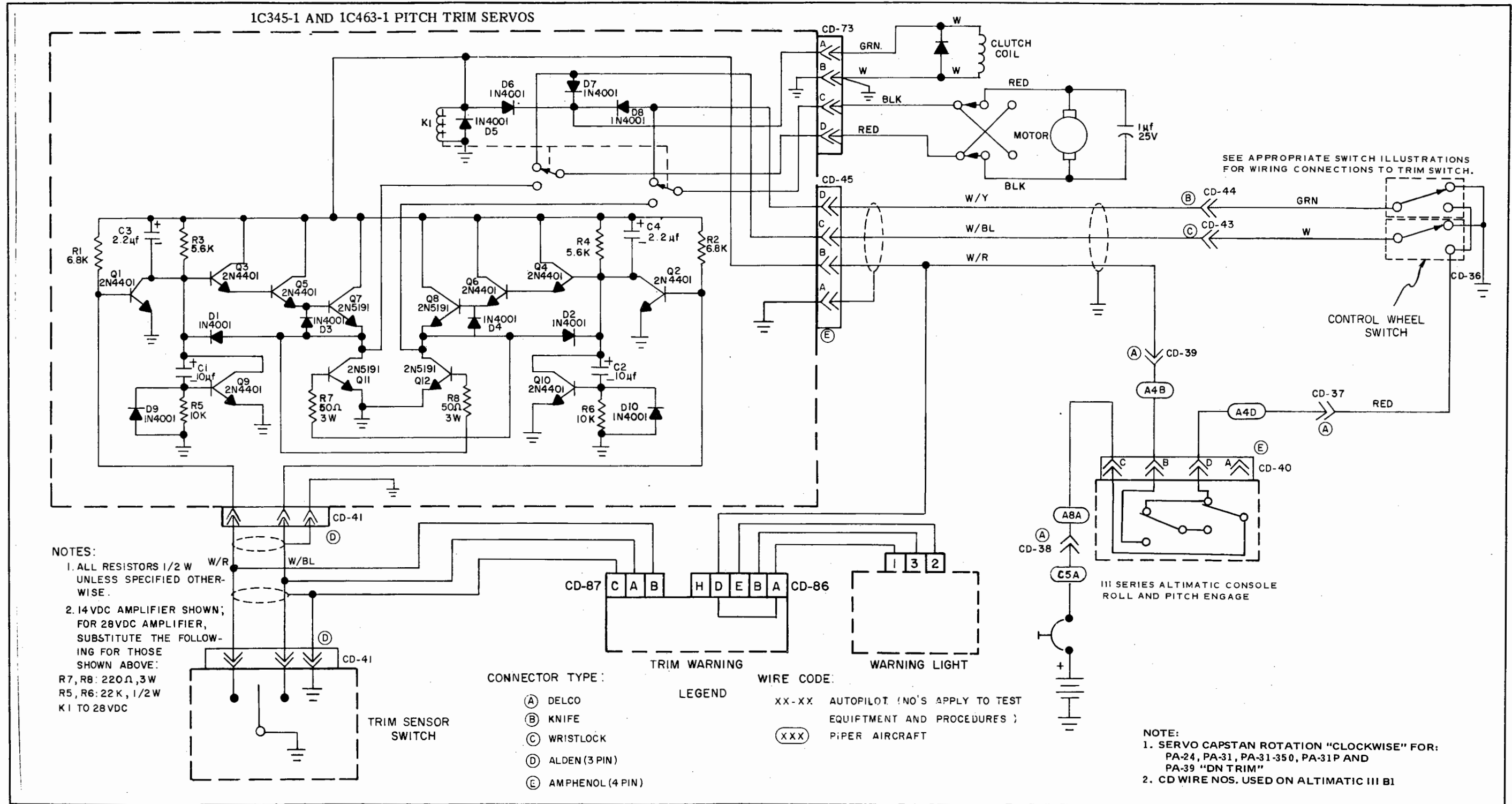

Figure 12-6. III Series Automatic Electric Trim Schematic AltiMatic III B-1 AutoPilots

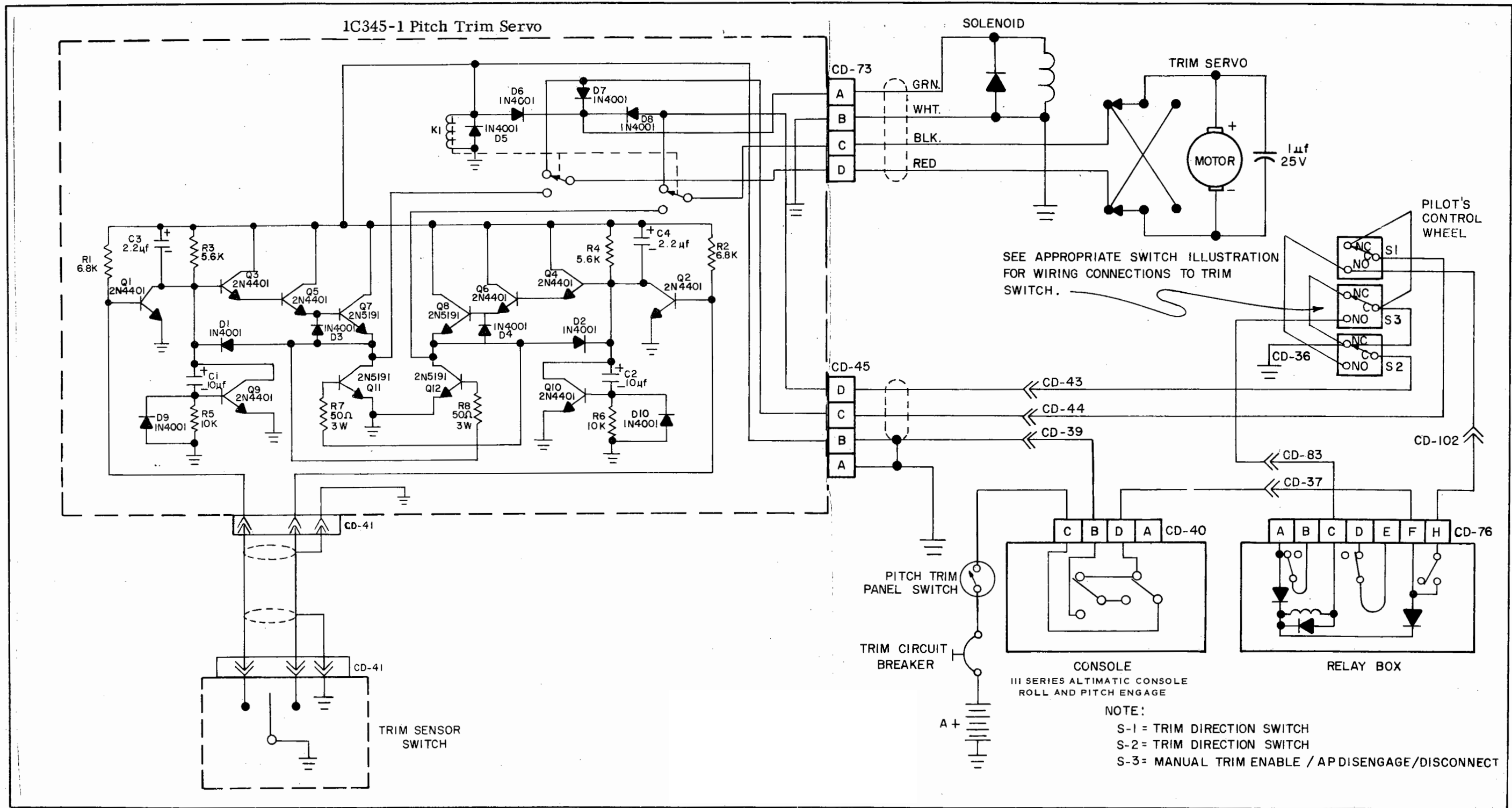

Figure 12-7. III Series Automatic Electric Trim Schematic AltiMatic III B-1 AutoPilots
PA-34-200

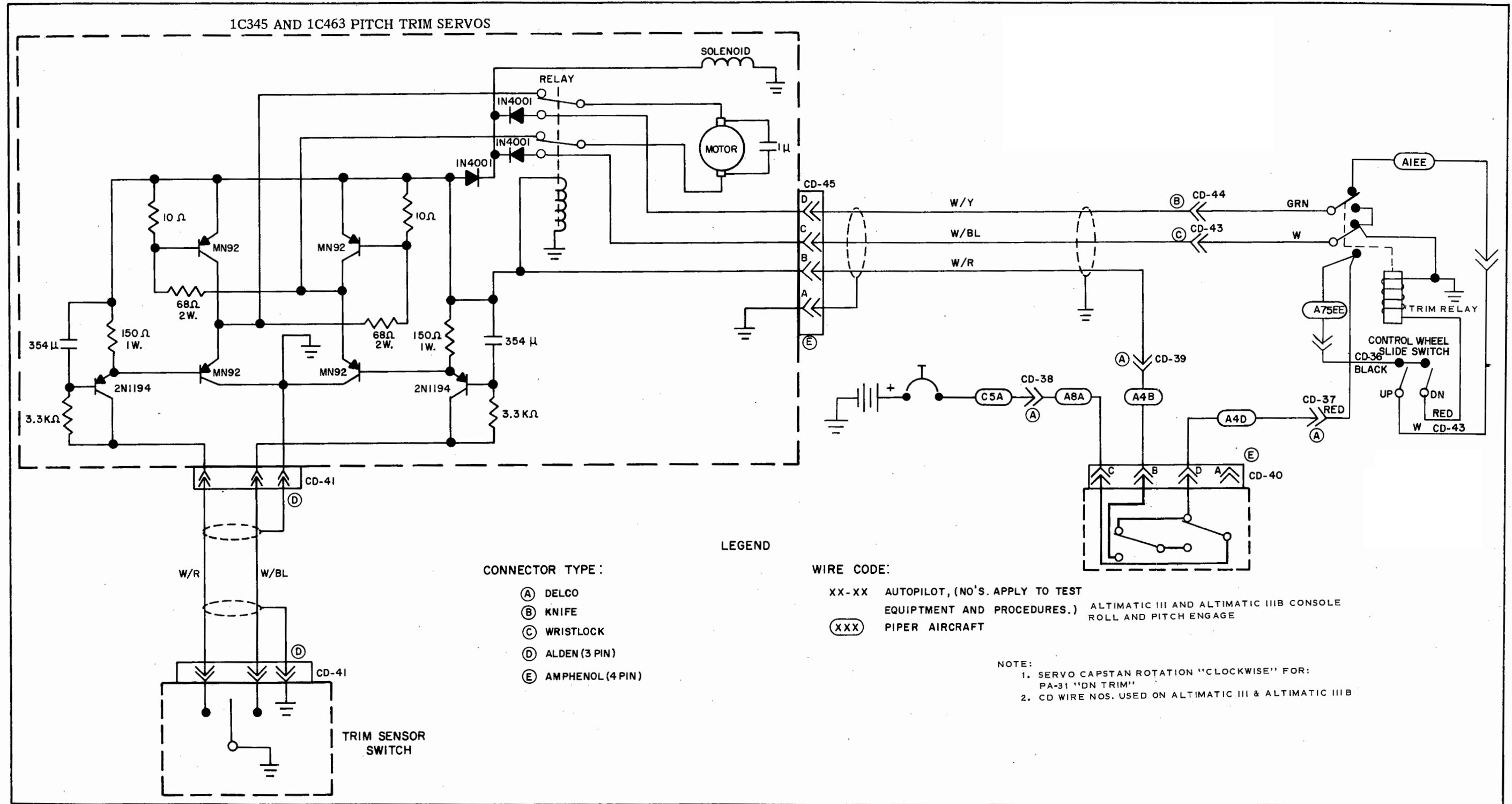

Figure 12-4. III Series Automatic Electric Trim Schematic (with trim relay) PA-31 Serial Nos. 31-1 to 31-424.

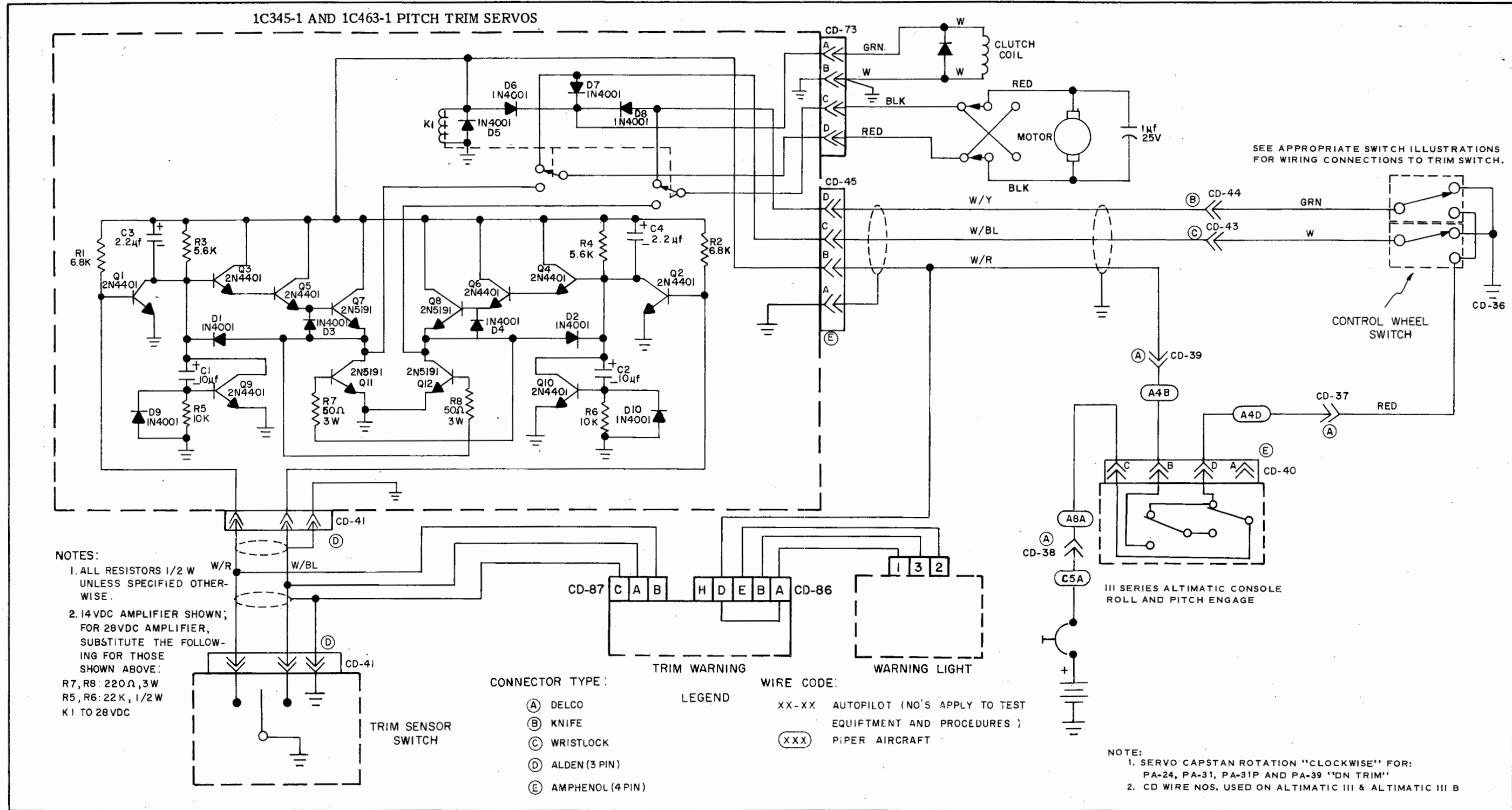

Figure 12-5. III Series Automatic Electric Trim Schematic AltiMatic III and III B AutoPilots

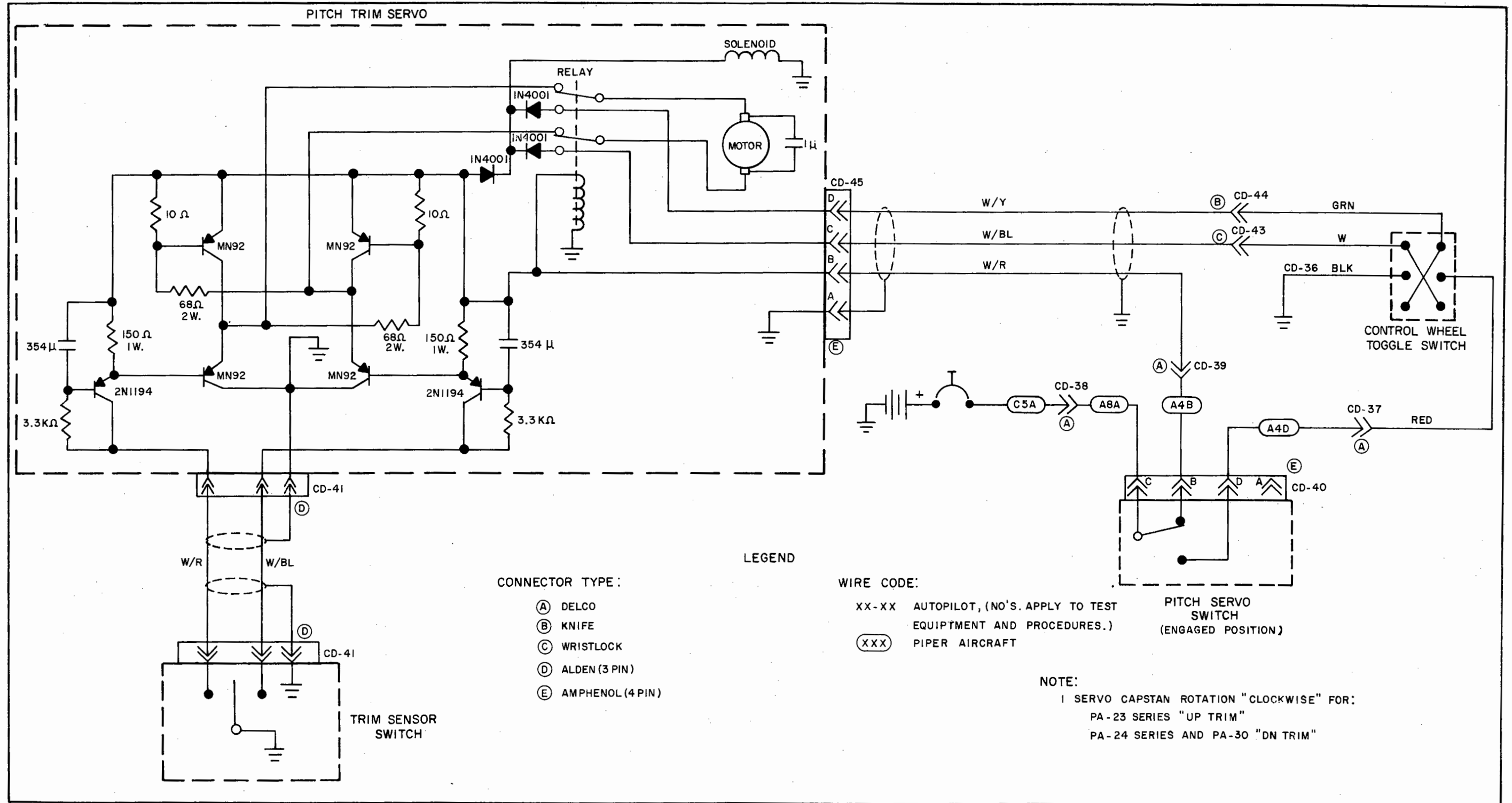

Figure 12-2. III Series Automatic Electric Trim Schematic AltiMatic II AutoPilot

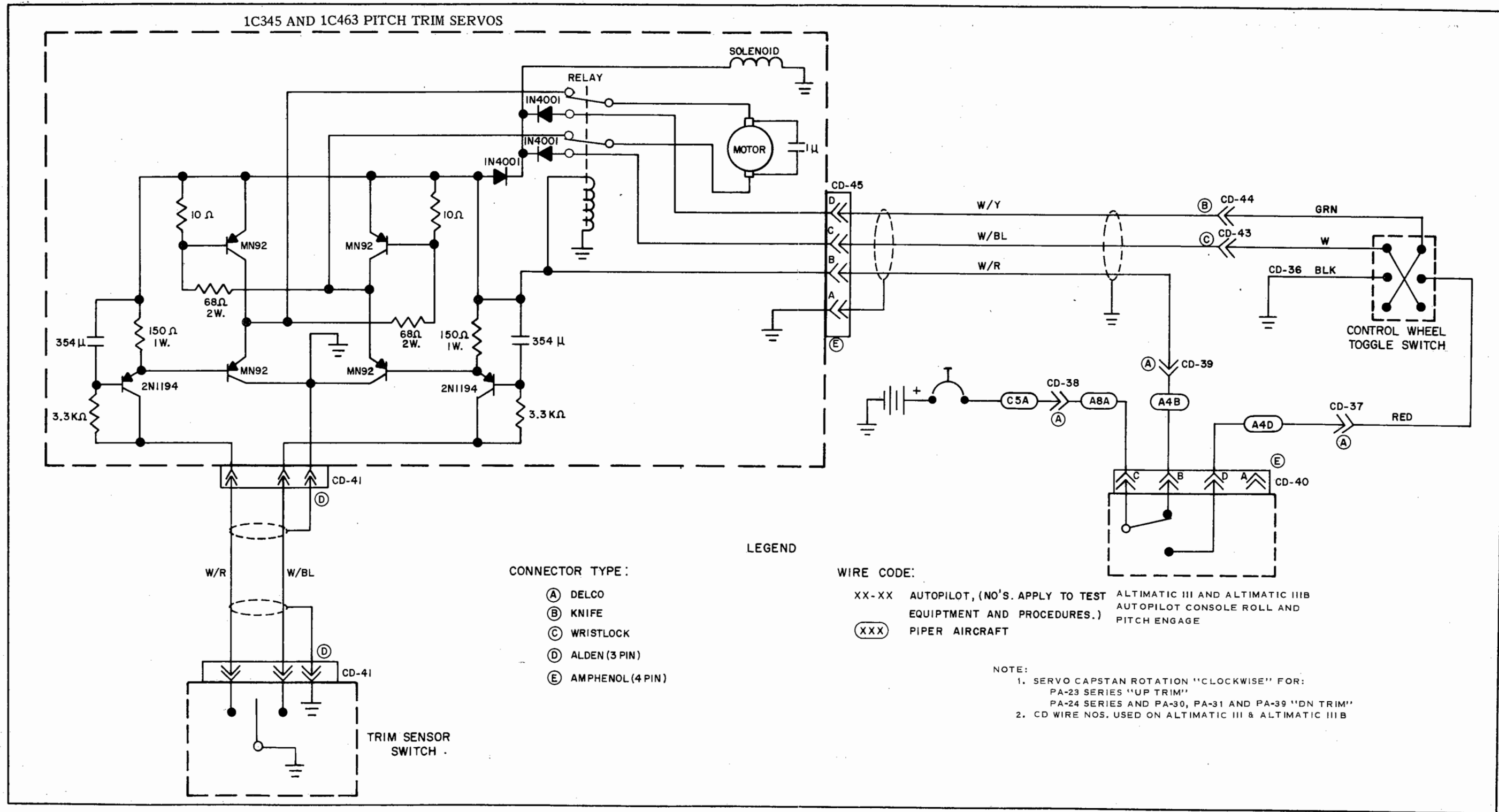

Figure 12-3. III Series Automatic Electric Trim Schematic (without trim relay) AltiMatic III and IIIB AutoPilots

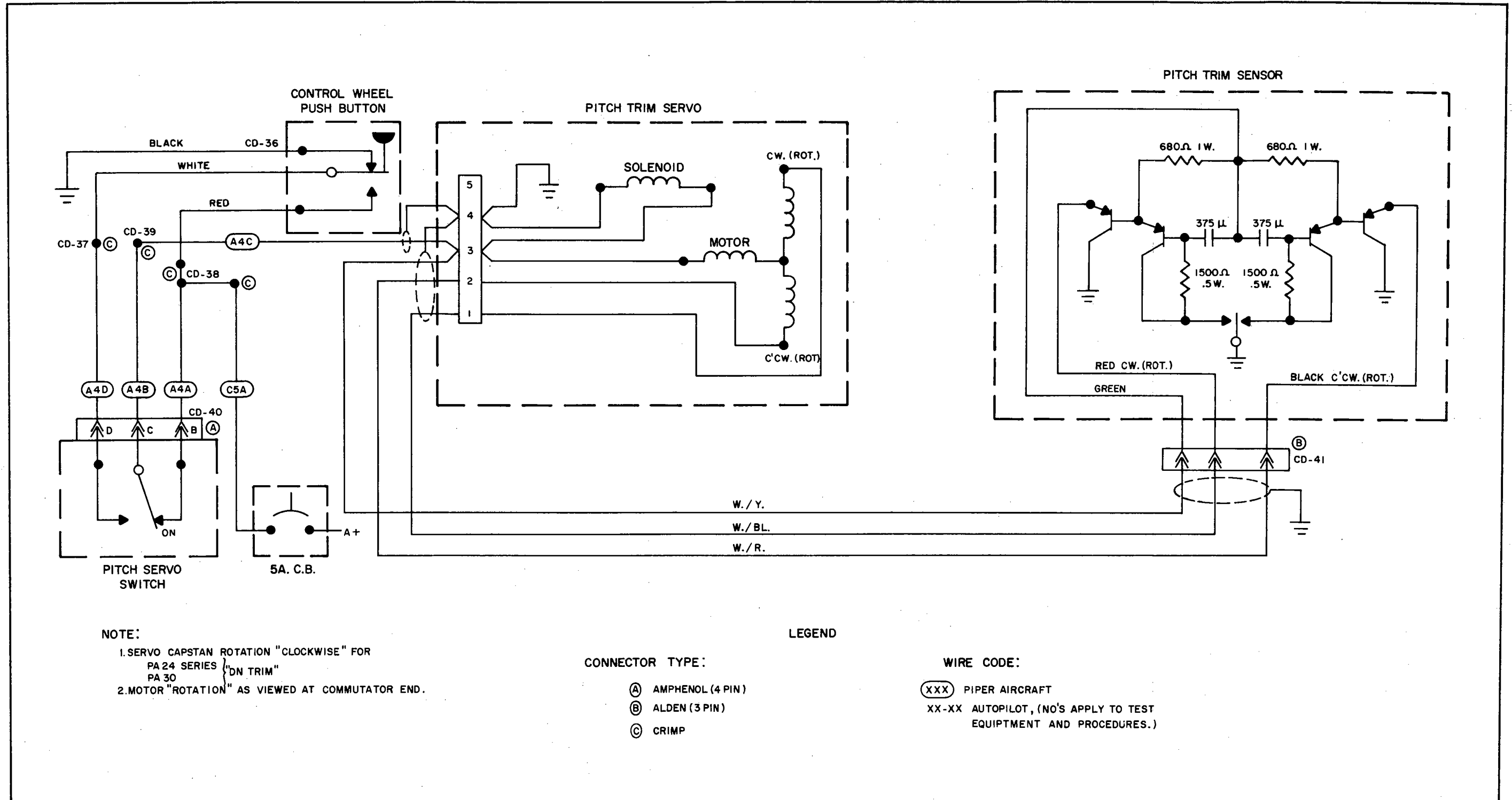

Figure 6-3. P.E.T. -1 Automatic Electric Trim Schematic

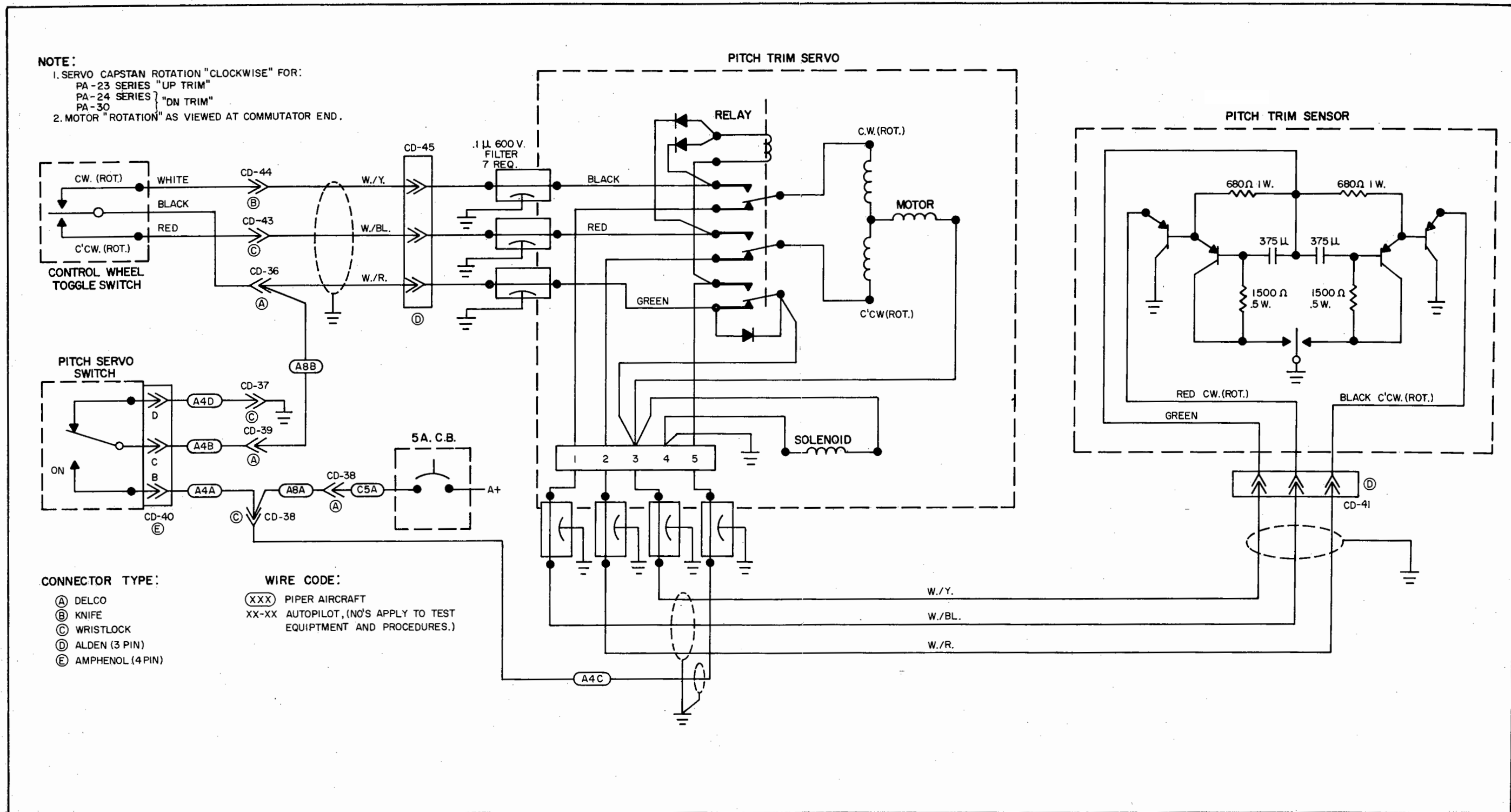

Figure 6-4. P.E.T.-2 Automatic Electric Trim Schematic

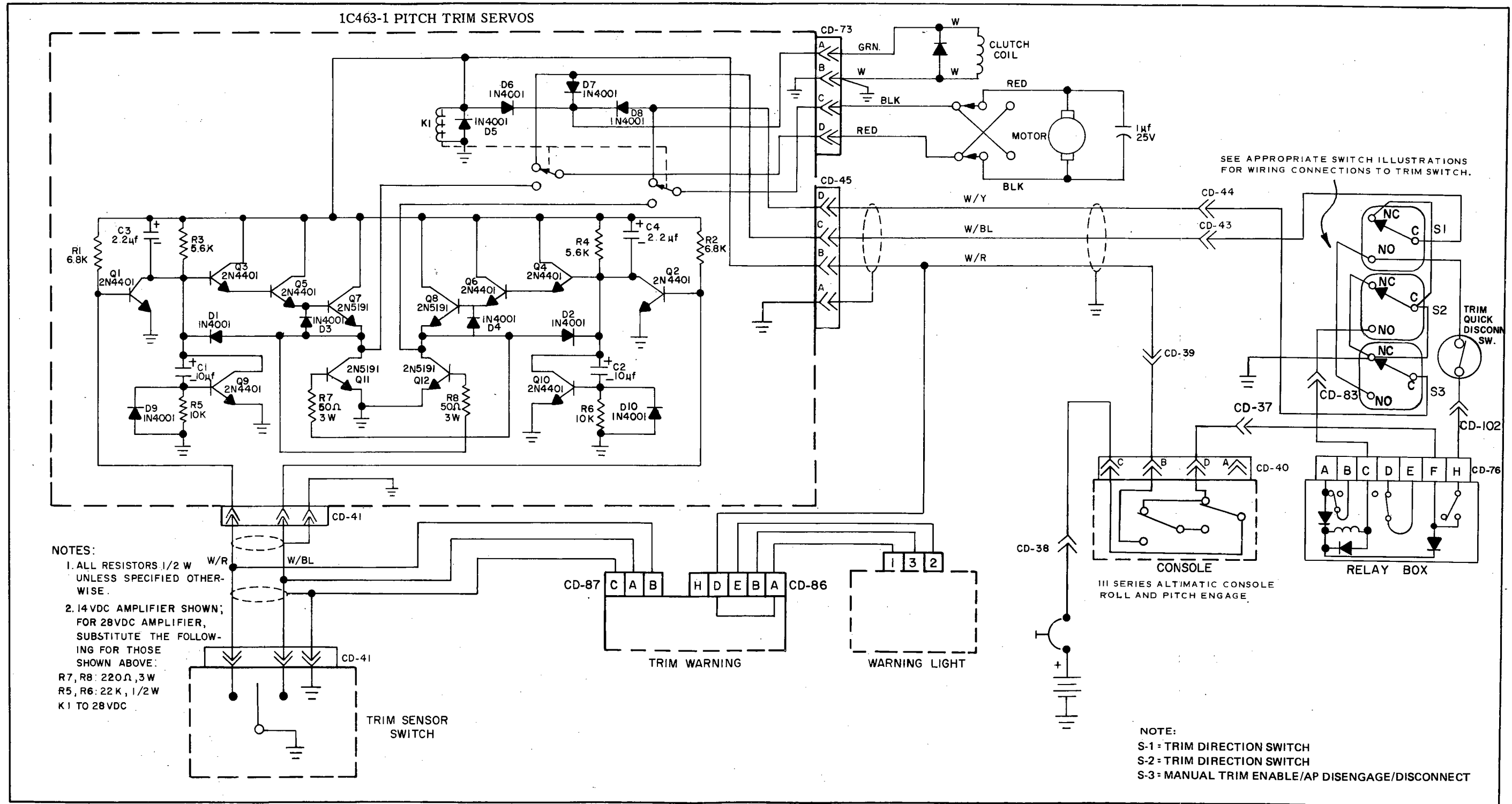

Figure 12-8. III Series Automatic Electric Trim Schematic AltiMatic III B-1 AutoPilots PA-31-350

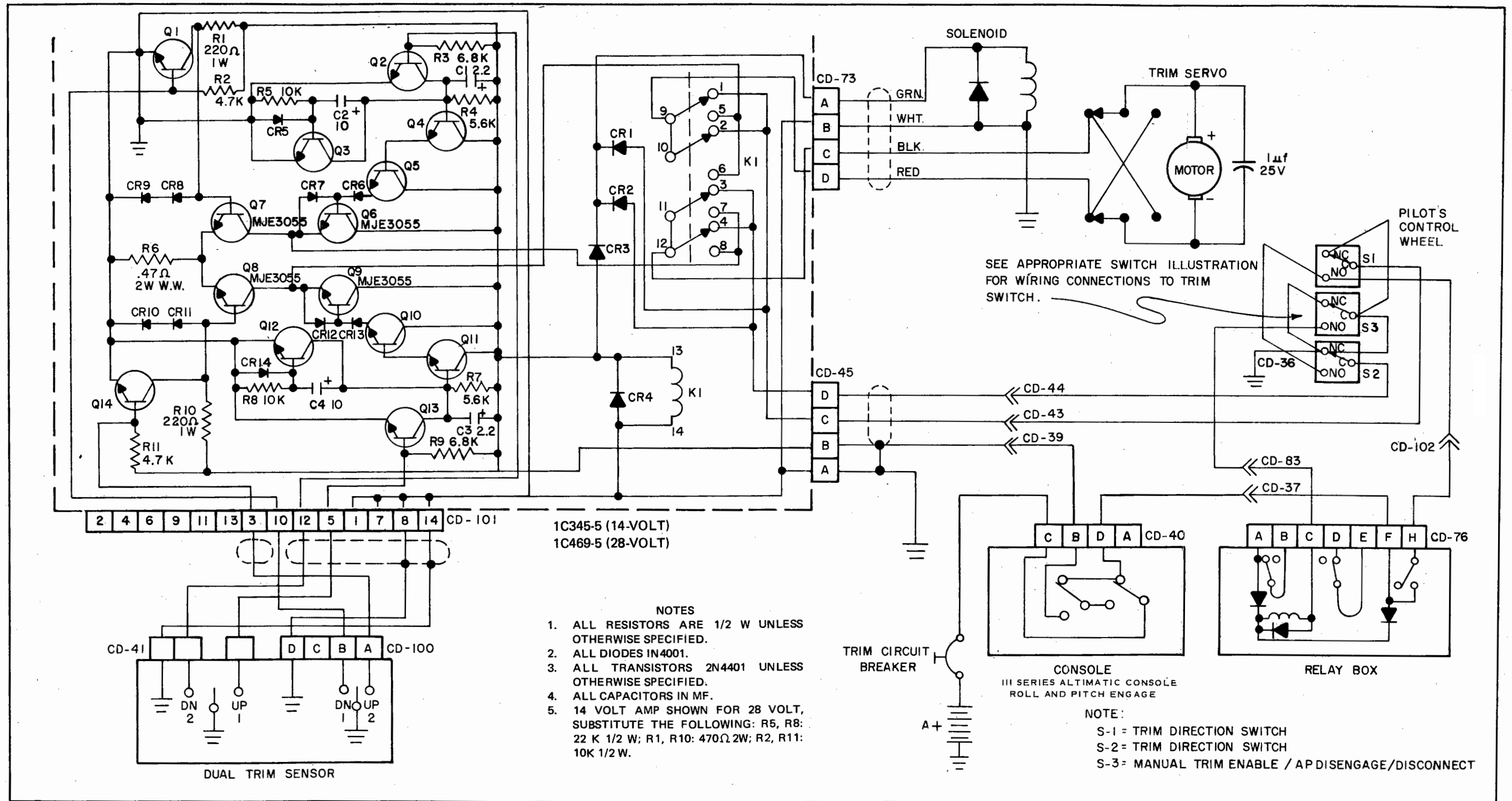

Figure 24-2. III Series Automatic Electric Trim Schematic (Dual Contact Type Trim Sensor) AltiMatic III B-1 Autopilots

PA-23-250

