

1 2 3 4 5 6

DO NOT SCALE

THIRD ANGLE PROJECTION

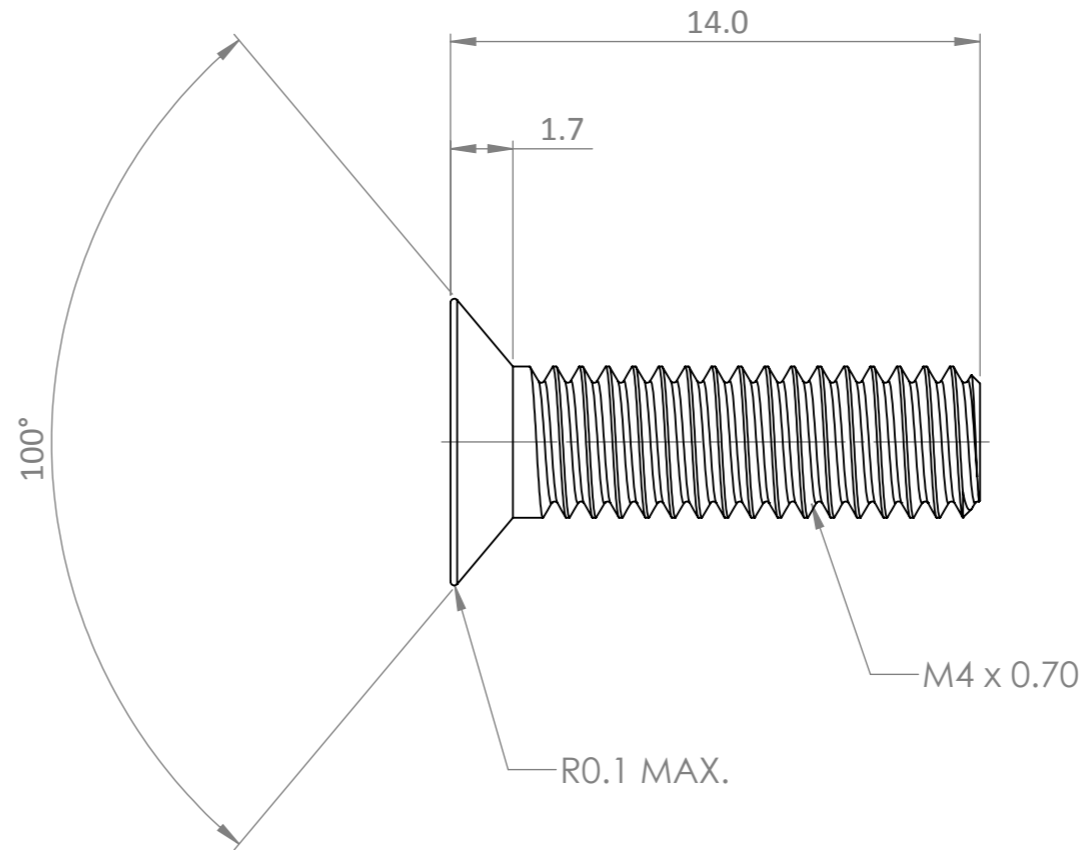
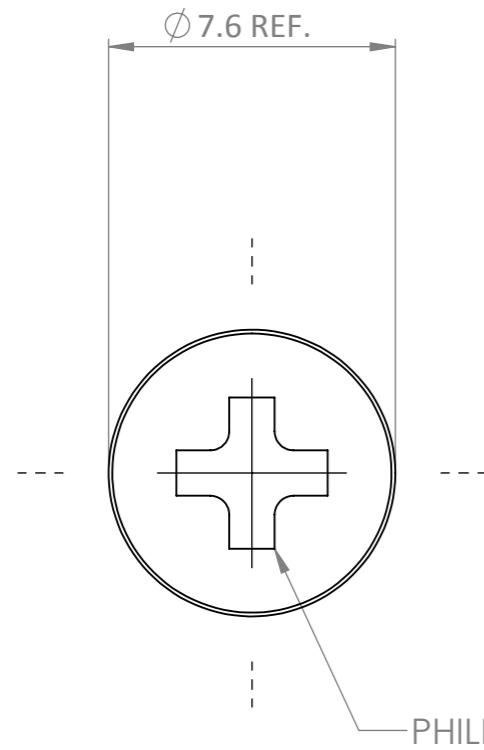
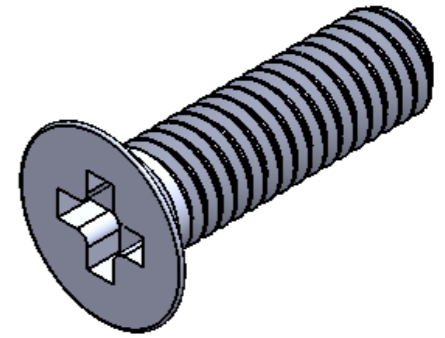
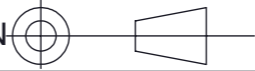

A
02/05/2014
ISS INSTRUCTIONS

UNLESS OTHERWISE STATED

MM DIMENSIONS, GENERAL TOLERANCES :-

- 2 DEC PLACES +/- 0.1
- 1 DEC PLACES +/- 0.2
- 0 DEC PLACES +/- 0.4

ANGLES +/- 3 DEGREES

SCREW THREADS TO BS3643 CLASS 6g/6H
DRAWING INTERPRETATION TO BS8888
SURFACE FINISH NOT WORSE THAN 3.2µm (Ra)
DIMENSIONS APPLY TO FINISHED PART.
INTERNAL RADII :- 0.3 TO 0.7
BREAK SHARP EDGES 0.5 MAX

MATERIAL

300 SERIES STAINLESS STEEL

DRAWN

FINISH

CHECKED

APPROVED

TITLE

PHILLIPS COUNTERSUNK HEAD SCREW

SCALE

NTS

DRAWING NUMBER

SHT 1
OF 1

A3